

FIELD MANUAL
NO. 44-85

HEADQUARTERS
DEPARTMENT OF THE ARMY
Washington, DC, 21 February 1997

PATRIOT BATTALION AND BATTERY OPERATIONS

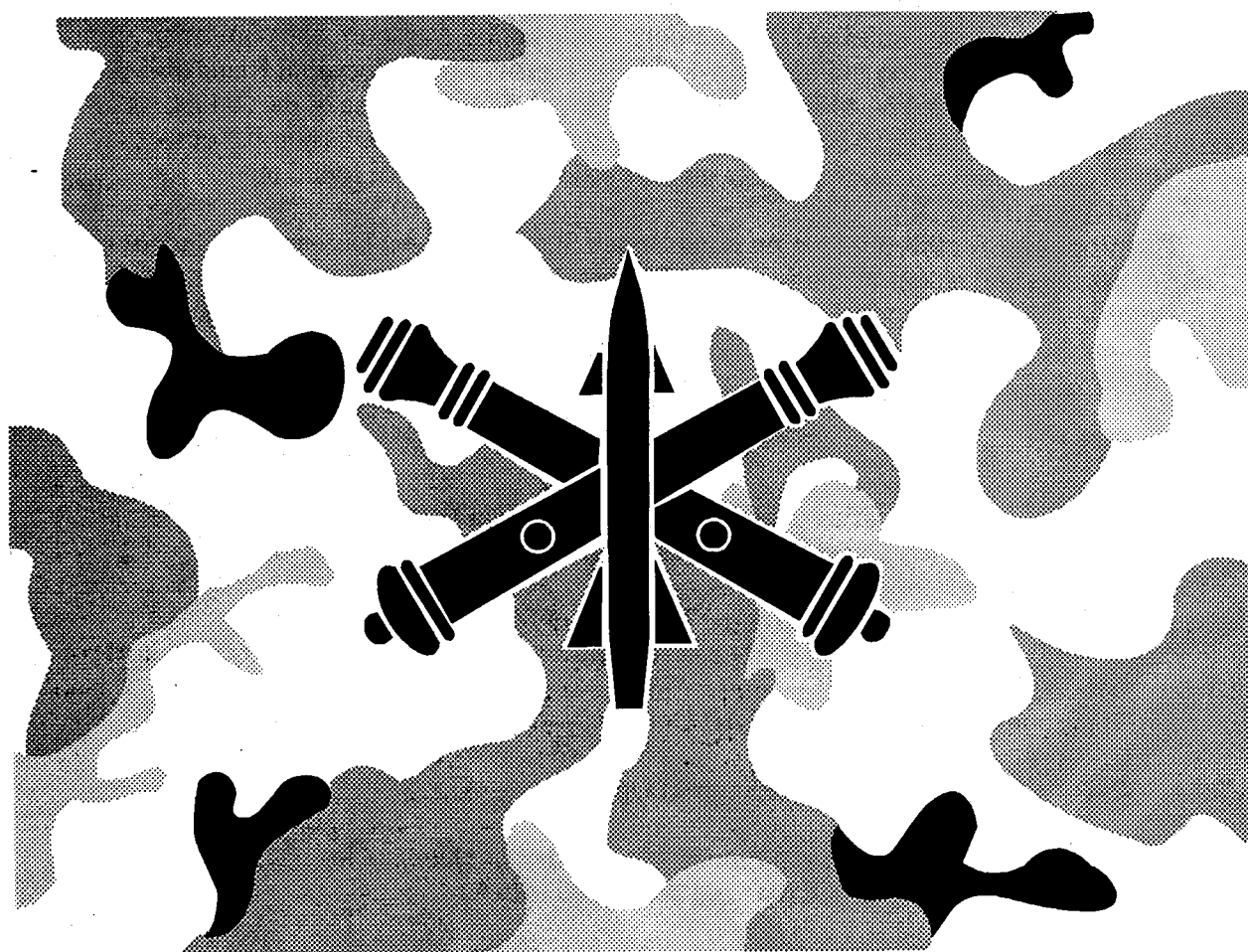

DISTRIBUTION RESTRICTION: Approved for public release; distribution is unlimited.

CONTENTS

	Page
Chapter 1 The Army Mission and the Role of Air Defense Artillery	1-1
The Army Mission	1-1
ADA Role	1-1
Patriot Mission	1-1
Doctrine	1-2
2 The Threat	2-1
Contingency Theater Threat	2-1
Threat During Lodgment	2-7
Threat as the Lodgment Expands	2-8
3 Patriot Battalion Planning	3-1
Battlefield Roles	3-1
Planning Considerations	3-3
ADA Brigade Planning	3-4
Battalion Planning	3-7
Rehearsals	3-9
4 Force-Projection Operations	4-1
Applicability	4-1
Predeployment Activity	4-2
Deployment and Entry Operations	4-3
Operations	4-4
War Termination and Postconflict Operations	4-4
Considerations	4-5
5 Operations	5-1
Offensive Operations	5-1
Defensive Operations	5-4
ABT Defense Design	5-5
TBM Defense Design	5-7
HIMAD Task Force	5-7
Defense Design Recommendations	5-14
Command, Control, Communications, and Intelligence	5-19
Remote Launch	5-20
Emplacement	5-21
6 Patriot Combat Service Support	6-1
Patriot Support Concept	6-1
Organizations and Functions	6-1
Planning	6-7
Operations	6-7
Supply	6-9

CONTENTS (Continued)

	Page
Maintenance	6-16
Transportation	6-18
Field Services	6-19
Rear Area Protection	6-19
Reconstitution	6-22
Appendix A Battalion and Battery Checklists	A-1
Preparation for Combat	A-1
Soldier's Checklist	A-1
Unit Vehicle Checklist	A-2
Towed Load Checklist	A-2
Patriot Equipment Checklist	A-3
Power Generator Checklist	A-4
Communications Equipment Checklist	A-4
Individual- and Crew-Served Weapons Checklist	A-5
MANPADS (Stinger) Checklist	A-5
Unit Operational Readiness Checklist	A-6
Battery Commander's Checklist	A-7
Briefing Checklist	A-8
RSOP Checklist	A-9
Staff Coordination Checklist	A-12
Ground Defense Checklist	A-13
CP Checklist	A-14
Convoy Checklist	A-16
MILVAN Storage and Shipping	A-18
MILVAN Unload Checklist	A-18
MILVAN Load Checklist	A-29
B Patriot Battalion Equipment and Organization	B-1
System Features	B-1
Patriot System Operational Overview	B-1
Patriot Battery Equipment	B-4
Patriot Battalion Fire Direction Center Equipment	B-20
Communications Relay Group	B-22
Antenna Mast Group	B-23
Radar Set, Semitrailer-Mounted, AN/MPQ-53	B-24
Electric Power Plant, Truck-Mounted	B-30
Launching Station, Guided Missile, Semitrailer-Mounted, M901	B-30
Patriot Guided Missile, Intercept Aerial, MIM-104	B-32
Patriot Maintenance Support	B-34
Tactical Equipment, Weights and Dimensions	B-41
Unit Organization	B-41

CONTENTS (Continued)

	Page
C IPB in Support of Air Defense Operations	C-1
The IPB Process	C-1
Define the Air Battlefield Environment	C-2
Describe the Battlefield Effects (Terrain/Weather Analysis)	C-2
Evaluate the Air Threat	C-4
Determine Air Threat Courses of Action	C-6
 D Battle Books	 D-1
Objectives	D-1
Preparation	D-1
 E Rail/Sea/Highway/Air Transportability	 E-1
Transportability Requirements Data	E-1
Rail Transport	E-1
Sea Transport	E-2
Highway Transportability	E-2
Guided Missile Transportability	E-2
Transportability Documentation	E-2
Air Transportability	E-3
Equipment Dimensional Characteristics	E-4
 F Safety	 F-1
Administrative	F-1
Risk Management Process	F-1
Vehicle Movement and Convoys	F-1
Safety From RF Radiation Hazards and Launcher Backblast	F-2
 G Communications	 G-1
Battalion Communications Equipment	G-1
Battalion Communications Requirements	G-2
Battery Communications Requirements	G-8
Patriot Communications Planning	G-12
Data Link Considerations	G-16
 Glossary	 Glossary-1
 References	 References-1
 Index	 Index-1

PREFACE

The purpose of this field manual (FM) is to provide doctrinal how-to-fight guidance for the Patriot battalion and battery in support of force-projection operations. Patriot officers and noncommissioned officers must possess an in-depth understanding of Army operations doctrine and how Patriot units play their part on the battlefield.

This FM is adaptable to any theater of operations. However, it focuses on contingency operations and Patriot's role in the projection of land and air combat power. It is intended primarily for battalion commanders, staff officers, battery commanders, platoon leaders, tactical directors, and tactical control officers.

Chapters address Patriot's role in the joint battle, the threat, air defense artillery (ADA) planning, force-projection operations, offensive and defensive operations, and combat service support. Appendices cover checklists, system and organizational descriptions, aerial intelligence preparation of the battlefield (IPB), safety, battle books, transport, and communications.

This FM is a companion to FM 44-85-1 (TBP). It provides the doctrinal framework to Patriot operations, while FM 44-85-1 (TBP) provides an understanding of the tactics, techniques, and procedures (TTP) so necessary to any discussion of Patriot's combat power. Classified capabilities and planning data on the Patriot system can be found in (S)FM 44-100A(U) (TBP).

The proponent for this publication is the United States Army Air Defense Artillery School. Send comments and recommendations on DA Form 2028 directly to Commandant, US Army Air Defense Artillery School, ATTN: ATSA-TAC-D, Fort Bliss, TX 79916-3802.

This publication implements the following NATO standardization agreements (STANAGS):

STANAG	TITLE	EDITION
2175	Classification and Designation of Flat Wagons Suitable for Transporting Military Equipment	3
2832	Restrictions for the Transport of Military Equipment by Rail on European Railways	2
3700	NATO Tactical Air Doctrine—ATP-33(B)	4
3736	Offensive Air Support Operations—ATP-27 (B)	8
3805	Doctrine and Procedures for Airspace Control in Times of Crisis and War—ATP-40(A)	4
3880	Counter Air Operations—ATP-42(B)	2

Unless this publication states otherwise, masculine nouns and pronouns do not refer exclusively to men.

CHAPTER 1

The Army Mission and the Role of Air Defense Artillery

This chapter discusses the changing nature of current political and military balances. This increases the likelihood that we will face the prospects of war throughout the world. The Army may fight in an austere theater having few initial US forces and an extremely immature sustainment base. In this environment, we will have to deploy, fight, and win against forces potentially superior to our own.

THE ARMY MISSION

The first mission of the Army is to deter war through readiness. If deterrence fails, the Army achieves a quick, decisive victory—on and off the battlefield—anywhere in the world and under virtually any conditions as part of a joint team. The Army requires a high degree of combat readiness to

project force whenever and wherever it is needed. Imperative to accomplishing this mission are well-articulated, war-fighting doctrine; appropriate mix of forces; realistic training; force modernization; competent and confident leaders; and the highest quality fighting force.

ADA ROLE

The mission of air defense artillery is to protect the force and selected geopolitical assets from aerial attack, missile attack, and surveillance. Air defense (AD) operations are key when generating combat power. They provide the force with protection from enemy air attack, preventing the enemy from separating friendly forces while freeing the commander to fully synchronize maneuver and firepower.

AD operations are performed by all members of the combined arms team; however, ground-based ADA units execute the bulk of the force-protection mission. These units protect deployed forces and critical assets

within a theater area of responsibility (AOR) by preventing enemy aircraft, missiles, remotely piloted vehicles (RPVs), and unmanned aerial vehicles (UAVs) from locating, striking, and destroying them.

The threat to friendly forces and combat functions is significantly greater than in the past due to weapons of mass destruction and the proliferation of missile technology. The potential for catastrophic loss of soldiers, time, or initiative, forcing a change to operational objectives, requires a greater role for theater missile defense when generating combat power.

PATRIOT MISSION

The mission of Patriot battalions and batteries is to provide ADA protection from all types of airborne threats from very low to high

altitudes to critical assets and maneuver forces belonging to the corps and to echelons above corps (EAC). The objectives of Patriot

FM 44-85

operations at all levels are to disrupt and destroy the enemy's ability to mount effective air operations, and in doing so, to retain

command and control (C²) capabilities, the freedom to maneuver, and the ability to support operations for our own forces.

DOCTRINE

This FM addresses doctrine and tactics for Patriot units and provides an overview of the environment in which Patriot units operate within the Army as well as with the other services. This FM should be used with

FM 44-85-1 (TBP), which provides the technical detail necessary to understand and effectively wield Patriot's considerable combat capability.

CHAPTER 2

THE THREAT

The primary focus of this chapter is the air and ground threat facing Patriot battalions and batteries in contingency theaters. The mature theater threat is not discussed, as the world is changing and the nature of this threat appears to be rapidly diminishing. Europe and the former Soviet Union have historically been viewed as the most likely areas of conflict for US forces. Recent Commonwealth of Independent States (CIS) reductions in conventional forces, combined with the collapse of communism in Eastern Europe and the unification of Germany, have caused the threat to ebb in Europe. The threat is more diverse now than ever before and includes almost all regions of the world. Regional powers continue to increase the sophistication and size of their military forces, thus posing a significant threat that the US Army must address.

CONTINGENCY THEATER THREAT

The threat in a contingency theater may lack the capability to conduct a massive Soviet-style air operation. However, most regional power adversaries have significant numbers of fixed- and rotary-wing aircraft, as well as sophisticated tactical ballistic missiles (TBMs). It is important for Patriot commanders to take this threat into account because even a small air force can make it difficult to establish and maintain a successful lodgment operation, especially if that air force is well-led and attempts to retain the initiative.

Rest of world (ROW) threats are many. Identifying each country, its tactics, weapon systems, and capabilities is an overwhelming task for a battalion S2 officer. Identifying and defining the basic characteristics of the primary air threat in the contingency area are very important. Combining the primary threat characteristics with a thorough IPB is the starting point for identifying the threat in any

contingency operation. IPB is discussed in Appendix C.

Listed in the following text are the primary threats to air defense in a contingency operation. A working knowledge of these threats is needed to effectively counter them.

DRONES

A drone is a land, sea, or air vehicle that is remotely or automatically controlled. There are several categories of drones, the most common air threats being UAVs and RPVs. A UAV is a powered air vehicle that does not carry a human operator, uses aerodynamic force to provide air vehicle lift, and is designed to carry a payload. A category or subset of UAV is the RPV. An RPV is an unmanned air vehicle controlled by a person from a distant location (once it is in operation) through a communications link.

Types of UAVs

The US military has classified four types of UAVs: close range, short range, medium range, and endurance. Categories and missions for these UAV types are identified in Table 2-1.

Mission of UAVs

The missions of UAVs vary. Their primary use is to obtain intelligence on opposing forces with reconnaissance, aerial surveillance, and targeting data. However, they have been used as decoys for aircraft and missiles. Using special electronic countermeasures (ECM) payloads, UAVs have been used to activate surface-to-air missile (SAM) radars. UAVs can also be used in laser designation, forward-looking infrared (FLIR) radar target

acquisition, harassment bombing, and chemical detection.

ROTARY-WING AIRCRAFT

Rotary-wing (RW) aircraft in the hands of regional power adversaries are limited in numbers as well as in operational effectiveness. Because these countries have not yet developed a sophisticated doctrine for combined arms, their use of RW aircraft will likely be limited. Most RW aircraft in the contingency threat originate from the CIS, France, and Germany. Many countries have RW equipment and tactics that come from many different sources. This may inhibit their use over a prolonged period due to maintenance, repair, and resupply

Table 2-1. UAV Categories and missions.

	CLOSE	SHORT	MEDIUM	ENDURANCE
MISSION	Recon, surv, tgt acq, tgt acq, SIGINT, EW, MET	Recon, surv, tgt acq, tgt spotting, MET, NBC, command & control, EW	Prestrike and poststrike recon, tgt acq, SIGINT, EW, MET	Recon, surv, tgt acq, command & control, MET, NBC, recon SIGINT, EW, special ops
LAUNCH AND RECOVERY	Land/ship board	Land/ship board	Air/land	Land
RADIUS OF CAUTION	Not specified	150 km beyond FLOT	650 km	Classified
SPEED	Not specified	Dash >110 knots Cruise < 90 knots	550 knots < 20,000 ft & Mach > 20,000 ft	Not specified
ENDURANCE	1 to 6 hrs	8 to 12 hrs	2 hrs	24 hrs on station
INFO TIMELINESS	Real time	Near real time	Near real time/ recorded	Near real time
SENSOR TYPE	Day/night imaging, EW, NBC	Day/night imaging data relay, comm relay, radar, SIGINT, MET, MASINT, tgt designate, EW	Day/night imaging, SIGINT, MET, EW	SIGINT, MET, comm relay, data relay, NBC, imaging, MASINT, EW
AIR VEHICLE CONTROL	None started	Preprogrammed/remote	Preprogrammed/ remote	Preprogrammed/ remote

requirements. The most common RW aircraft within the third world are the Hip, Hind, Gazelle, and B0 105. Additionally, there are many RW aircraft, now used for transport or liaison, that can easily be converted for combat missions. The avionics sophistication of the RW aircraft is also limited. Night operations are virtually nonexistent. Basic tactics such as flying nap of the earth and flying in pairs are to be expected.

MISSILES

There are two basic types of surface-to-surface missiles (SSMs). They are tactical ballistic and cruise. Tactical ballistic missiles (TBMs) are rocket-powered during the initial stages of flight only. Therefore, the missile follows a ballistic trajectory once the rocket burns out. The long-range ballistic missiles fly much of their trajectories outside the atmosphere. Cruise missiles (CMs) use a booster rocket during the launch stage but during flight depend on an air-breathing engine similar to those used in airplanes. They may fly at low or very low altitudes. In the next decade, cruise missiles will pose a serious challenge. ROW countries will have access to land attack CM technology. The guidance systems use navigational signals transmitted by satellites. A receiver, costing only a few thousand dollars, enables the missiles to have an accuracy within 100 meters. CM warheads may include such variants as cluster munitions, intelligent submunitions, and fuel-air explosives.

Tactical Ballistic Missiles

TBMs are perhaps the most alarming air threat in the ROW regions. Commonly known

as the "poor man's air force," their proliferation was rapid during the 1980s and will continue through the 1990s. Regional powers have access to many different types of missiles, some available with ranges extending to thousands of kilometers. Short-range ballistic missiles (SRBMs) are missiles with a range of 200 kilometers or less. The most common SRBMs in the third world are the free rocket over ground (FROG) and the SS-21. The Scud and SS-12 are also abundant. These are considered medium-range ballistic missiles (MRBMs) with ranges from 200 to 900 kilometers.

Missile Availability

Many countries already possess the capability to manufacture their own rocket systems. These countries then deploy or export them to other countries. Presently, countries that have deployed ballistic missiles are Libya, North Yemen, Syria, Iraq, Israel, Egypt, Iran, Kuwait, South Yemen, Taiwan, Cuba, North Korea, Pakistan, Algeria, and South Korea. A correlation exists between the acquisition of missiles and the acquisition of nuclear, biological, and chemical (NBC) programs. Three countries are believed to have nuclear weapons in stock or ready for easy assembly. They are India, Israel, and Pakistan. Argentina, Brazil, South Africa, and Iraq have significant nuclear programs. Countries believed to have stockpiles of chemical weapons are Egypt, Iran, Iraq, Israel, Libya, North Korea, South Korea, South Africa, Syria, and Taiwan. The four countries alleged to have stockpiles of biological weapons are Iran, Iraq, North Korea, and Syria. The next two tables (pages 2-4 and 2-5) outline the ROW countries that most likely have ballistic missiles.

Table 2-2. Third world medium-range missiles, 200 to 900 kilometers.

COUNTRY	SYSTEM	STATUS	ORIGIN	RANGE (KM)	PAYLOAD (KG)
Afghanistan	Scud B	dep & emp	CIS	280	1,000
Brazil	SS-300	suspended(?)	Brazil	300	NA
	MB/EE-350	under dev	Brazil	350	NA
	MB/EE 600	under dev	Brazil	600	NA
Egypt	Scud B	dep & emp	CIS	280	1,000
	Scud 100	under dev	Egypt with tech asst from PRC, North Korea	NA	NA
	Al-Zafir	canc in 1960s	Egypt with tech asst from FRG sources	370	NA
	Al-Hussein	canc in 1960s	Egypt with asst from FRG sources	600	NA
India	Privthi	tested 1988	India	250	1,000
Iran	Scud B	dep & emp	N. Korea, Libya, Syria	280	1,000
Iraq	Scud B	dep & emp	CIS	280	1,000
	Al-Hussein	dep & emp	Iraqi modified Soviet Scud. Iraq with tech asst from Egypt, Brazil	600	140-250
Israel	Fahd	under dev	Iraq	500	450
	Baraq	under dev	Iraq	250	NA
	Jericho 1	dep(?)	Israel with tech asst from France	480	250
Libya	Jericho 2	dep(?)	Israel	750	450-680
	Scud B	dep & emp	CIS	280	1,000
	OTRAG	under dev(?)	Libya with tech asst from FRG sources	500	-
North Korea	Al-Fatih	under dev(?)	Libya with tech asst from FRG	480-720	NA
	Scud B	dep	Missiles from Egypt, N. Korea reverse engineered	280	1,000
	Scud PIP	under dev	N. Korean modified Scud with tech asst from Egypt, Japan	500	NA
Pakistan	Hatf 2	tested 1989	Pakistan with tech asst from France	300	500
South Yemen	Hatf 3(?)	under dev	Pakistan	600	NA
	Scud B	dep	CIS	280	1,000
South Africa	Jericho 1(?)*	tested 1989	Israel	480	250
South Korea	Modified Nike Hercules	dep	S. Korea, modified US technology	240	NA
Syria	Scud B	dep	CIS	280	1,000
	OTRAG	canc 1981	Libya with tech asst from FRG sources	-	-

* Some sources claim the missile to be a Jericho 2.

Source: Adelphi Papers #252, Ballistic Missile Proliferation in the Third World, pages 30-31, Summer 1990 edition, published by International Institute for Strategic Studies.

Table 2-3. Third world short-range missiles, less than 200 kilometers.

COUNTRY	SYSTEM	STATUS	ORIGIN	RANGE (KM)	PAYLOAD (KG)
Algeria	FROG-4	deactivated	CIS	50	250
	FROG-7	dep	CIS	70	450
Argentina	Condor 1	under dev	Argentina, tech asst from Egyptian, French, German, Iraqi, Italian, Swedish, and Swiss sources	150	400
Brazil	MB/EE 150	under dev	Brazil	50	250
Cuba	FROG-4	dep	CIS	70	450
	FROG-7	dep	CIS	80	200
Egypt	Sakr 80	dep*	Egypt with tech asst from France	50	250
	FROG-5	dep	CIS	70	450
India	FROG-7	dep & emp	CIS	140	NA
	Devil	canc in 1970s	India with tech asst from CIS	100	NA
Indonesia	RX-250	under dev	Indonesia with tech asst from France	40	300
Iran	Oghab	dep & emp*	Iran, PRC	130	NA
	Nazeat	dep	Iran, PRC	110-130	NA
Iraq	Shahin-2	under dev	Iran, PRC	70	450
	FROG-7	dep & emp	CIS	90	NA
Israel	Laith	under dev	Iraq (modified Soviet FROG)	110	NA
	Nissan	under dev	Iraq	150	NA
	Kassir	under dev	Iraq	120	200
	Lance	dep	USA	200	NA
Kuwait	Flower	canc in 1970s	Israel		
	Project			70	450
Kuwait	FROG-7	dep	CIS	70	450
Libya	FROG-7	dep	CIS	50	250
North Korea	FROG-5	dep	CIS	70	450
	FROG-7	dep	CIS	120	250
North Yemen	SS-21	dep	CIS	80	500
Pakistan	Hatf 1	tested 1989	Pakistan with tech asst from French sources	37	580
South Korea	Honest John	dep	US	70	450
South Yemen	FROG-7	dep	CIS	120	250
	SS-21	dep	CIS	70	450
Syria	FROG-7	dep & emp	CIS	120	250
	SS-21	dep	CIS	37	580
Taiwan	Honest John	dep	USA	120	NA
	Ching Feng	dep	Taiwan, Israel		

* May be classified as artillery rockets. Other countries with artillery rockets are Brazil, Iraq, Israel, and Saudi Arabia.

Source: Adelphi Papers #252, Ballistic Missile Proliferation in the Third World, pages 30-31, Summer 1990 edition, published by International Institute for Strategic Studies.

Political or Military Use

TBMs can be used as political weapons or military weapons. Because there are few long-range targeting assets in the third world, it is most likely that political, religious, and economic targets will be attacked, rather than strictly tactical or operational targets. Iraq's use of ballistic missiles during the Persian Gulf War is an indication of how these missiles might be used in the future, especially if they are equipped with chemical or nuclear warheads. Attacking an enemy's population centers creates psychological terror. Unless such missiles are credibly countered, public or international support for friendly military operations may be weakened.

Military Use

Militarily, TBMs can be used in fire support or preemptive strikes. They maximize the advantages of speed, surprise, and disruption. Ballistic missiles can be used in all weather conditions and at night.

FIXED-WING AIRCRAFT

Fixed-wing (FW) aircraft will always be a priority for the Air Force. However, the ADA

community must stay in tune with the ROW aircraft imports and avionics developments. Since the Persian Gulf War, several Middle East countries have sought to replace their aging aircraft. Most Middle East countries are turning to the US for imports. The CIS, France, and Britain are also exporters of aircraft and aircraft systems. It is less expensive and easier to improve aircraft by advanced avionics than purchase new aircraft. Therefore, many older aircraft may be used with updated avionics and weapons.

INTELLIGENCE PREPARATION

To effectively counter the regional threat, a thorough evaluation of the threat's capabilities, strengths, and weaknesses must be conducted. The Patriot battalion commander should ensure that intelligence information on regions and countries that may become areas of conflict for the battalion is continuously gathered, evaluated, and disseminated. The battalion's intelligence officer should keep abreast of this information and, immediately following alert notification, be able to address the questions in Table 2-4.

Table 2-4. Intelligence questions table.

General:	
<ul style="list-style-type: none">• What country has most influenced the tactics of the threat force (US, CIS, France, or Britain)?• What is the size of the military the Army will face?• Is equipment modernized or outdated?• Do terrorists or special forces pose a viable threat to ADA units?• What are local attitudes about US forces?	<ul style="list-style-type: none">• Do they possess and effectively use ASMs and ARMs?• What is the combat radius of each type of threat aircraft?• Where are the operating bases and secondary airfields located?• What type of ordnance delivery techniques and attack profiles are used?• Do the aircraft have night flight capability?• How proficient are the pilots at navigation?• Are the aircraft equipped with sophisticated avionics?• What types and numbers of RW aircraft does the threat possess?
Air Force:	
<ul style="list-style-type: none">• Do threat pilots have combat experience?• What types of air-to-ground tactics does the threat most often use?• What ordnance does the threat use?• What is the threat sortie generation capability?• How many aircraft are fully operational?• Do they possess air refueling capability?	ECM: <ul style="list-style-type: none">• Does the threat possess ECM or electronic surveillance measure (ESM) capabilities? What are they?

Table 2-4. Intelligence questions table. (Continued)

<ul style="list-style-type: none"> • How is ECM most commonly employed against radars and communications? • Can the threat use chaff, flares, smoke, or jamming vehicles? • Does the enemy have antiradiation missiles? <p>TBM:</p> <ul style="list-style-type: none"> • What types and numbers of TBMs does the threat have? • What are the ranges and accuracies of these TBMs? What is the relationship of range to accuracy? • What types of ground support requirements do specific types of TBMs require? Do they have specialized 	<ul style="list-style-type: none"> launchers, or can launchers be easily fabricated? Do they have special fuel requirements? • How many TBMs can be placed on one target simultaneously? • What types of warheads can be mounted on the TBMs? • What types of emanations are associated with the launch of TBMs? <p>NBC:</p> <ul style="list-style-type: none"> • What type of NBC capabilities does the threat possess? • What type of delivery means can they employ?
---	--

THREAT DURING LODGMENT

During entry operations, friendly heavy forces will normally enter a lodgment through seaport and airport areas that are secured from ground attack by light and special operations forces. However, long-range air attacks and missile strikes remain a major concern. During disembarkment into the lodgment, heavy forces are most likely to be attacked by enemy missiles, FW aircraft, and artillery. Once the lodgment has been secured from ground attack, Patriot units may be deployed at any time. During Operation Desert Shield in Saudi Arabia, Patriot units deployed on the heels of airborne units. When the threat of TBM attack exists, Patriot

will likely be deployed early because the defense of the lodgment is so critical to the rest of the operation. The lodgment is the base of operations for US forces deployed from CONUS. Assets likely to be targeted within the lodgment would include seaports, airfields, lines of communications, command and control headquarters, logistical resources, and ground forces. Sabotage and terrorist actions remain a danger, and commanders must ensure that their soldiers stay alert to this threat as well as the sentiments of the local populace. Also to be considered is the threat to friendly population centers and commercial activities (Figure 2-1).

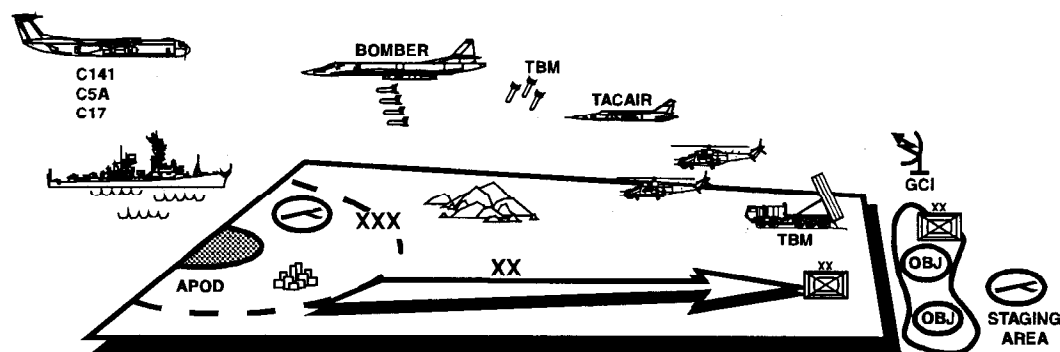

Figure 2-1. Aerial threat during lodgment operation.

THREAT AS THE LODGMENT EXPANDS

As friendly forces begin combat operations or movement beyond the lodgment, the enemy is likely to employ TBMs, CMs, UAVs, and RW and FW aircraft against maneuver units and their support mechanisms.

Missiles likely to be used in forward areas include the full range of short-range TBMs—some examples are the FROG, SS-21, and SS-23.

TBM delivery of persistent chemicals or tactical nuclear weapons could cut off support for forward forces. Medium-range missiles, like the Scud and its variants, could be used against Patriot units in rear areas, as well as against command, control, communications, and intelligence (C³I) nodes and logistics

support facilities. Air defense of the lodgment area remains critical because the threat against it may exist throughout the operation.

The threat facing Patriot units in contingency theaters is diverse and capable. The air battle in such a theater may encompass the full range of threat TBMs, CMs, UAVs, aircraft, and electronic warfare. In some cases, we may face military organizations that are larger than our own. Tactics, weapon systems, training, and capabilities vary from region to region. The threat may possess weapons that are in some ways superior to ours. The key to winning is thorough intelligence preparation.

CHAPTER 3

PATRIOT BATTALION PLANNING

This chapter describes the ADA planning as a top-down, interactive planning process between ADA elements and the units they defend. The objective of ADA planning is to synchronize air defense at the critical time and place on the battlefield. Patriot units are organic to both EAC and corps organizations and have two distinct, but complementary, roles on the battlefield.

BATTLEFIELD ROLES

In force-projection operations, EAC Patriot may initially be employed to provide protection against the TBM and CM threat to lodgment areas, provide firepower against the air-breathing threat (ABT), enhance long-range surveillance, and provide C² links to evolving joint structures. As the operation progresses, corps and divisional units arrive and move from the lodgment into tactical assembly areas. The focus of corps Patriot units will likely change from protection of the lodgment to defense of the maneuver force and expansion facilities.

Corps Patriot units will be employed against tactical air and missile attacks tied to enemy ground maneuvers in the corps and division areas. Depending upon mission, equipment, terrain, troops, and time available (METT-T), EAC Patriot assets may be pushed forward into the corps rear area to augment corps high- to medium-altitude air defense (HIMAD) coverage. Corps Patriot assets may also be pushed forward to augment the divisional ADA units.

PLANNING PROCESS

Extensive, detailed planning is key to the success of Patriot in force-projection operations. Since the Patriot battalion generally operates under the C² of an ADA brigade, the planning process begins with the brigade. The

battalion's coverage and firepower must be fully integrated with the brigade's battle plan to ensure effective and timely support of the ground commander's operation. This chapter covers the scope of the AD planning process of the ADA brigade, battalion, and battery. ADA planning is the process of—

- Understanding the mission.
- Understanding the commander's intent.
- Analyzing METT-T factors through an aerial IPB.
- Considering priorities.
- Constructing a decision support template (DST).
- Identifying priorities in terms of time and space.
- Analyzing and structuring the AD scheme of maneuver.
- War-gaming applicable courses of action (COAs).
- Implementing the optimum AD design.

Figure 3-1 depicts on the left, the Army's decision-making process. Key to this process is the IPB process shown on the right. A thorough evaluation of the threat forms the basis for the staff estimate process and the war-gaming of possible friendly courses of action. An initial DST is developed and presented along with friendly COAs for approval. The final goal of the planning process is to produce the decision support matrix (DSM) and operation

order (OPORD). See Appendix C for a complete discussion of the IPB process.

BATTLEFIELD OPERATING SYSTEMS

The seven battlefield operating systems (BOSS) are used to systematically ensure that all elements of the organization's combat power are directed toward accomplishing the overall mission and supporting the commander's intent.

Patriot tactical planners should consider all BOSs to determine Patriot responsibilities to each BOS, and to fully support the ground commander's intent. BOSs are the major functions performed by the force on the battlefield to successfully synchronize operations,

Intelligence

This is a continuous, integrated, and comprehensive evaluation of how the terrain, weather, and threat affect the areas of operation and interest.

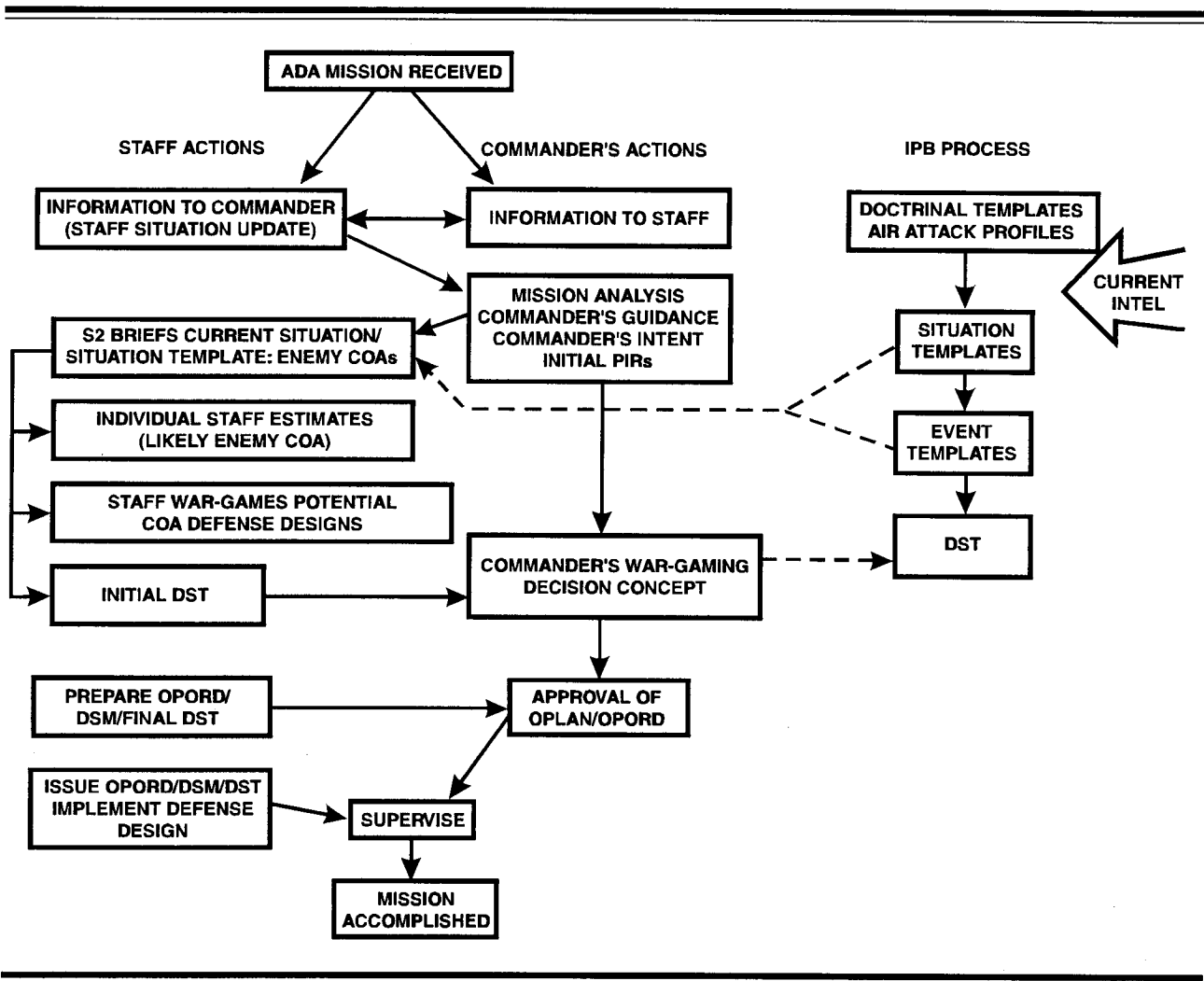

Figure 3-1. Decision process.

Maneuver

Maneuver is the movement of forces to secure or retain positional advantage in relation to the enemy. It is the dynamic element of combat and the means of concentrating forces at the critical point to achieve the surprise, shock, momentum, and dominance that allows one force to defeat another. Maneuver requires mobility, support, and protection.

Fire Support

This is the firepower that provides the destructive force essential to defeating the enemy's ability and will to fight. It eases maneuver by suppressing the enemy's fires and disrupting the movement, C², and sustainment of threat forces.

Mobility and Survivability

Mobility is the freedom to maneuver. This can be strategic sea or airlift, operational deployment, tactical road march, or the ability to move all unit equipment by available organic or nonorganic means.

Survivability protects friendly forces from enemy weapon systems and natural occurrences. Hardening of facilities, fortification of battle positions, moving at night, and destroying enemy air platforms are active survivability measures. Passive survivability measures include camouflage, dispersion, passive radar emplacement, EMCON, and OPSEC. NBC defense measures are also key survivability operations.

Air Defense

Air defense provides the force with protection from enemy air attack. This BOS degrades the effectiveness of threat air operations through active means, such as ADA, and through passive means such as concealment, emissions control, and airspace management.

Combat Service Support (Logistics)

The force's center of gravity can usually be found in its support structure. The key logistics functions are manning, arming, fueling, fixing, moving, and sustaining the soldiers and their systems. While ensuring adequate support for the force, commanders must also conserve for future operations.

Command and Control (Battle Command)

This is the art of battle decision making, leading, and motivating soldiers and their organizations into action to accomplish missions. It includes visualizing the current state and future state, then formulating operational concepts to get from one to the other at the least cost. It also includes assigning missions, prioritizing and allocating resources, selecting the critical time and place to act, and knowing how and when to make adjustments during the fight.

PLANNING CONSIDERATIONS

The EAC brigade initiates the ADA planning cycle to support the theater campaign plan. The corps ADA brigade planning supports the corps scheme of maneuver. EAC brigades operating in or adjacent to corps areas must coordinate planning with the corps ADA brigade to synchronize the effort to counter

aviation and missiles directly supporting enemy ground maneuver. The Theater Army Air Defense Command (TAADCOM) commander monitors the corps planning process, the corps commander's intent (or corps commanders' intents, where the theater contains more than one corps), the friendly scheme of maneuver,

and the enemy air and ground situation. This coordination allows EAC air defenders to visualize the battle, thus enabling them to be at the critical time and place to destroy the maximum number of enemy aircraft and missiles. Consistent with their theater responsibilities, EAC brigades should attempt to defend as many assets in the corps rear as possible, freeing corps HIMAD to mass fires forward.

The Patriot battery is the lowest echelon at which Patriot fights. Normally, Patriot units fight as a battalion. Defense design is a prime

consideration of the planning process. This is accomplished through the application of AD employment principles, employment guidelines, and weapon system design capabilities to the terrain and the tactical situation. This incorporates the positioning of individual batteries and how they will work together to increase their collective combat power. A well-developed defense design which supports the maneuver scheme increases the effectiveness of air defenses and unit survivability. AD operations planning must be the focus of the enemy air threat commander.

ADA BRIGADE PLANNING

The objective of planning at the ADA brigade level is a successful, well-coordinated AD operation that supports the commander's intent. The products of the brigade's planning process are the brigade DSM and the OPORD. The DSM is a planning technique used to coordinate the brigade's fight against a number of potential enemy COAs. Paragraph 3 of the OPORD contains the commander's intent statement. The commander's intent is his view of the flow of the battle. It gives his subordinates a concise overview of his priorities for the major operations, and most importantly, provides a framework for the continued execution of operations in the absence of directives or orders. The brigade OPORD sets the battlefield geometry for the upcoming battle and gives guidance to subordinate battalions. The EAC brigade ensures integration of theater operations with the corps scheme of maneuver; the corps brigade integrates AD coverage with the maneuver unit's mission.

PRIORITIZATION

To properly prioritize assets, the mission analysis must consider the criticality, vulnerability, recuperability, and threat (CVRT) to

each asset. The brigade commander and his staff identify ADA priorities in time and space. Based on the DST (see Figure 3-2) and their understanding of the supported commander's intent, they consider the CVRT of each defended asset, in the context of the threat. The battalion commander recommends these defense priorities to the supported commander. Once approved, these priorities provide initial input into the defense design process for positioning and system initialization of Patriot batteries.

Criticality

Criticality is the degree to which a maneuver force or asset is essential to the mission accomplishment. It is determined by assessing the operational impact that would result from damage to the maneuver force or asset.

Vulnerability

Vulnerability is the degree to which a maneuver force or asset is susceptible to attack or damage. Thought should be given to the hardness; specific mission, ability to disperse or displace, organic ADA assets, and passive AD capability.

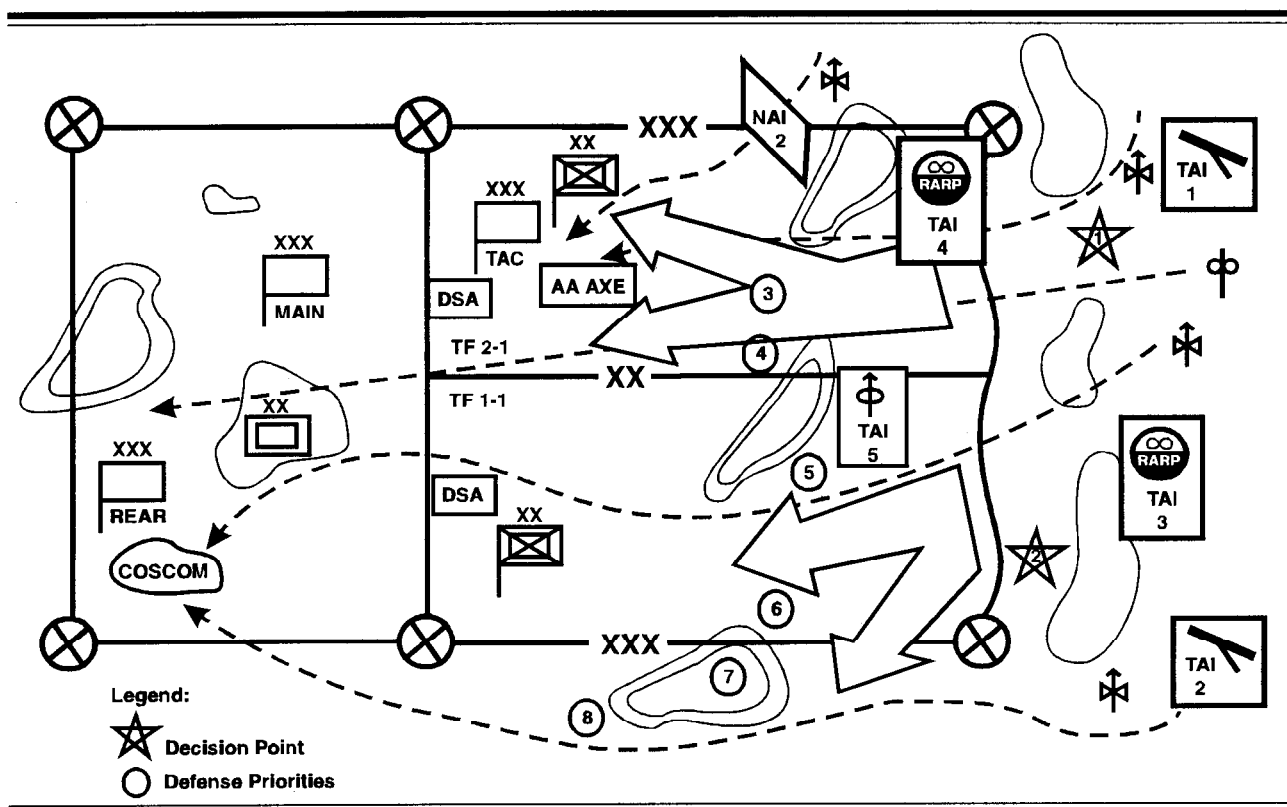

Figure 3-2. Decision support template.

Recuperability

Recuperability is the degree to which a maneuver force or asset could recover from damage in terms of time, equipment, and manpower to accomplish its mission.

Threat

Threat considers the probability that an asset will be targeted for attack. This assessment considers why a friendly asset is a lucrative target for the enemy, what types of weapons may be used for the attack, and when such an attack might take place.

CONCEPT OF OPERATIONS

While the commanders and operations officers are analyzing the mission, the intelligence officer develops the IPB. The brigade commander

gives his concept of the operation to the staff after he has received the IPB briefing, the joint force air component commander's (JFACC) or area air defense commander's (AADC) guidance, the corps commander's AD priorities, and future corps operations or missions, if applicable. Using operational concepts such as preplanned defense designs and considering the IPB, the commander issues initial guidance and suggests COAs for staff consideration. Staff estimates are conducted, COAs are developed, evaluated, and war-gamed, and then an initial plan is approved by the commander. When the order is published, an initial DSM is constructed (Table 3-1). Backbriefs from the subordinate commanders ensure that the commander's intent and ADA scheme of maneuver are understood. The DSM is refined and rehearsals are conducted.

Table 3-1. ADA brigade decision support matrix sample.

TIME	H+6	H+24
ENEMY ACTION	<ul style="list-style-type: none"> • Scud attack APOD/SPOD • Limited FW attacks • UAV RISTA • Monitors movement 	<ul style="list-style-type: none"> • Scud attacks APOD/SPOD • UAV RISTA • First use of RW • Fights from prepared positions
DP		<ul style="list-style-type: none"> • Launch deep attack
MANEUVER	<ul style="list-style-type: none"> • Corps continues expansion of lodgment and conducts movement to contact 	<ul style="list-style-type: none"> • 24 Inf Div main attack • 1 Cav Div supporting attack
ADA DP		<ul style="list-style-type: none"> • Reinforce main attack
PATRIOT BN	<ul style="list-style-type: none"> • GS Corps TBM mode • Priority to APOD/SPOD/CSS 	<p>No change</p>
HAWK BN	<ul style="list-style-type: none"> • GS Corps • Priority to maneuver forces • Coverage to PL blue 	<ul style="list-style-type: none"> • GS Corps • Priority to maneuver forces • Coverage to PL red
AVENGER BN	<ul style="list-style-type: none"> • GS Corps • Counter-RISTA 	<ul style="list-style-type: none"> • GS Corps • Counter-RISTA • 0/0 1 btry GS-R to main attack
C ²	<ul style="list-style-type: none"> • TOC MV150231 • TOC moving 	<ul style="list-style-type: none"> • TOC MV150231 • TOC MV150231
EW	<ul style="list-style-type: none"> • AWACS on station • JTAGS operational 	<p>No change</p>
A ² C ²	<ul style="list-style-type: none"> • UAV launch recovery site (LRS) vic MC2510 	<ul style="list-style-type: none"> • ATACMS firing VIC MV3955 • CAB attack EA dog along route cobra
CSS	<p>No change</p>	<ul style="list-style-type: none"> • New ASP established vic MV915845

BATTALION PLANNING

Key

The emphasis of the battalion commander's planning is on mission execution. The final product of planning is the execution matrix. Operational guidance from the brigade serves as the foundation for battalion staff planning. The battalion S2 modifies the brigade IPB to fit the battalion mission and area of operations (AO). The battalion commander provides his intent and guidance. His staff develops COAs that are war-gamed to ensure they support the goals of shoot, move, communicate, survive, and sustain. The objective of battalion planning is to be prepared to defeat enemy air and

“ The commander’s intent is designed not to restrain, but to unleash a subordinate by giving him greater freedom of action to accomplish the mission. ”

General John W. Foss

missile attacks in the battalion's area of responsibility and to ensure synchronization of battalion efforts with both ground forces and other AD forces. The battalion staff produces an OPORD and execution matrix for the batteries. The OPORD and execution matrix time phases the batteries' actions and movements, gives primary target lines (PTLs), dictates emission control (EMCON), and gives the location of key C² and logistics facilities.

PROCESS

Upon receiving a warning of a new mission, the battalion staff conducts an ADA estimate, armed with the brigade DSM. The brigade DSM provides the battalions with a concept of operations for integration into the corps or EAC fight, execution guidelines, intelligence information (both ground and air), logistics support concept, and C information.

IPB is key to the planning process. It is a systematic and continuous approach to analyzing the enemy, terrain, and weather in a specific geographic area. It integrates enemy doctrine with weather and terrain as they relate to the mission and the specific battlefield environment. The IPB is conducted to determine and evaluate enemy capabilities, vulnerabilities, and probable COAs. The ADA brigade S2 coordinates with the G2 to determine the location of the enemy's expected main attack and the ground threat in the corps and theater rear. In coordination with the G2, the S2 determines the enemy air order of battle, probable air avenues of approach (AAOAs), anticipated location and composition of the enemy's RW and FW threat, sortie rates, aircraft types, and airfield locations. Also assessed are potential uses of TBMs, CMs, UAVs, and ground, FW, and RW jammer capabilities (Air IPB is covered in greater detail in Appendix C.).

How

The battalion S2 selects named areas of interest (NAIs) from the brigade IPB which allow him to follow major enemy air and ground actions. The S2 then lays out the aerial terrain analysis upon the condensed ground IPB, identifies key areas of possible enemy penetration into the battalion area of responsibility, and determines potential use of his air and missile capabilities. He identifies priority intelligence requirements (PIRs), which should provide a picture of enemy air capabilities and intentions, and requests an update on PIRs previously submitted to higher echelon intelligence sources. Potential targets for missile, RW, and FW attacks are identified, as are probable locations of enemy jamming assets. The S2 displays his analysis using a DST, a drawing of the condensed ground IPB with the terrain, air

analyses, and the selected ground and air NAIs through the entire depth of the battlefield.

WAR-GAMING

Based on a review of the new mission, current status, and anticipated action, the battalion staff war-games possible COAs. The battalion executive officer is normally responsible for supervising and coordinating the war-gaming phase of the planning process. His principal functions are to integrate the planning functions of all staff areas, ensure they have correctly visualized the

battlefield, and integrate the battalion's actions for the coming fight.

DECISION SUPPORT MATRIX

The brigade DSM establishes the parameters under which the battle will be fought. It should specify battalion sectors, orientation, logistics, and the defense design wanted by the brigade commander. The battalion commanders then backbrief to the brigade commander their understanding of the plan and their mission to ensure there are no misunderstandings. The battalion commander and the S3 then develop the execution

Table 3-2. Execution matrix.

ELEMENT	EVENT							
	H+1	H+2	H+3	H+4	H+5	H+6	H+7	H+8
CBT TRAINS	LA124356	MWO KA235560		MEO KA235560	EN ROUTE	EN ROUTE	MCR KA235560	
ADM	LA123460							
FDC	MWO KA234567	ADV PARTY DEPARTS KA234567	JUMP OPNL KA234567	CONTROL TO BDE	MEO KA234567	MCR KA234567	MCR KA234567	RESUME CONTROL FROM BDE
ALPHA BTRY	EMCON SILENT PTL 120	EMCON SILENT	TBM SEARCH PTL 120	MWO KA123654	MWO KA123654	EN ROUTE KA123654	MCR KA123654	LINKTO ICC TBM SEARCH PTL 140 ON ORDER
BRAVO BTRY	MWO LA122345	MEO LA123345	EN ROUTE LA123333	MCR LA123456	EMCON SILENT PTL 140	EMCON SILENT	TBM SEARCH PTL 140 ON ORDER	LINKTO ICC TBM SEARCH PTL 140 ON ORDER
CHARLIE BTRY	MEO LA222341	MCR LA233412	ABT SEARCH PTL 90	ABT SEARCH PTL 90	ABT SEARCH STL 120	ABT SEARCH STL 120	ABT SEARCH PTL 90	LINKTO ICC TBM SEARCH PTL 90
DELTA BTRY	EMCON SILENT	EMCON SILENT	TBM SEARCH PTL 80	MASTER BTRY	TBM SEARCH PTL 80	TBM SEARCH PTL 80	TBM SEARCH PTL 80	LINKTO ICC TBM SEARCH PTL 80

matrix. This specifies battalion actions in terms of time or events. Table 3-2 is an example of a battalion execution matrix. It

correlates the battalion elements (condensed for this example) with the time-guided events.

REHEARSALS

Rehearsals at all levels are an integral part of the planning process. Rehearsals ensure understanding of the operational concept, verification of specific responsibilities, action timing, and backup procedures to help synchronize unit operations. At all levels, the commander or unit leader should conduct the rehearsal.

WHEN AND HOW

Rehearsals should be as complete as time allows. In time-constrained situations, the rehearsal can be abbreviated to focus on only the most critical portions of the operation, as prioritized by the commander. METT-T will determine the type or extent of a rehearsal. A good time schedule in the warning order will identify and assist in the prioritization of tasks to be rehearsed. Allow enough time for subordinates to conduct their own rehearsals. Remember, battle crews, platoons, and batteries are Patriot's main killers in the air battle. Whenever possible, these are the elements that need to conduct full force rehearsals.

STANDING OPERATING PROCEDURES

Inherent in making the proper decision regarding rehearsals is an assumption that all elements of the Patriot battalion are familiar with the various techniques of rehearsals, and that they have practiced these techniques prior to deployment. If the battalion has not developed detailed SOPs and is not proficient in rehearsals during home-station tactical training prior to deployment, rehearsals (as well as operations) have a poor chance of success. There is not enough time

on the battlefield to develop rehearsal SOPs and proficiency. Some items that should be included in a rehearsal annex to the battalion tactical standing operating procedure (TSOP) are as follows:

- Individual responsible for rehearsal training aids or simulations.
- Levels of rehearsal to be established. This includes who participates, what type of rehearsal technique is used, and where the rehearsal occurs.
- Materials to be carried, where and by whom.
- Individual to announce rehearsals by type, and when they are to be announced.

Regardless of the procedure used to designate rehearsal types, participants, and so on, that procedure should be the result of home-station trial and error refinement. Every time the task force conducts combat maneuver training at any level, the elements participating in that training should also be training in rehearsal techniques.

A standard for measuring the effectiveness must be established by the chain of command, and rehearsals should be evaluated and critiqued. Unless an ongoing system of evaluation and feedback exists, training will occur that is not the standard, including rehearsal training.

REHEARSAL CATEGORIES

Rehearsals are key to synchronization. They reveal flaws in the plan and ensure that everyone knows what to do at the correct time. Shortfalls noted in rehearsals must be fed back into the planning process. Rehearsals fall into three types or categories: backbrief, reduced force, and full force.

Backbrief

This method identifies problems and disconnects in execution. It should be used as frequently as possible and, when possible, with other types of rehearsal. One of the best benefits of backbriefs is to clarify the commander's intent. The backbrief may take two different forms. One method occurs when subordinates repeat to the commander what he wanted them to do and why. The second, and perhaps more crucial, is the opportunity for the subordinate commanders to tell the commander how they are going to accomplish their parts of the mission. When used this way, subordinate leaders must identify all specified and implied missions, critical tasks, and give their restated mission. Subordinates should continue until they accomplish this. All should understand the mission, commander's intent, concept, and their role and timing to complete their tasks.

Reduced Force

When time is limited or the tactical situation does not permit everyone to attend, then rehearsal is conducted with a reduced force. For example, it may be done with only commanders, key staff, tactical directors, and tactical control officers using maps, battlefield mock-ups, or as noted below, the Patriot simulation capability. Even when time is not limited and everyone can attend, commanders should consider a reduced force rehearsal before any full force rehearsal. An after action review (AAR) is essential to making the most of this type of rehearsal.

Full Force

When time is available, rehearsing with the entire battalion or battery is the ideal. Depending on the overall training status of the unit

involved, it should be started under ideal conditions and proceed gradually toward realistic conditions.

Because of the nature of Patriot battalions and the widely dispersed areas over which they operate, the most common types of rehearsals used are backbrief or reduced force. Also, the Patriot system has extensive simulation capability, and when time permits, this may be used to rehearse both battalion and battery system operators in engagement operations specific to the operation at hand.

ADA BRIGADE

At the brigade level, the commander normally conducts a backbrief or a reduced force rehearsal with the battalion and support commanders, the brigade staff, and liaison officers. The brigade commander walks through the plan discussing contingencies and potential problem areas, giving the specifics of their plans, and modifying the brigade DSM and the battalion execution matrix as necessary.

PATRIOT BATTALION

At the battalion level, the commander conducts a backbrief rehearsal with battery commanders. When time permits, a reduced force rehearsal should be conducted with battery commanders and first sergeants, the support unit commander, battalion staff, battalion fire direction center (FDC) officer in charge (OIC), liaison officers, and anyone else who may be key to the plan. The rehearsal should include a walk-through of the battalion execution matrix. The focus should be to identify shortcomings in planning and coordination, and ensure that all personnel thoroughly understand not only their part in the operation, but the roles

and functions of everyone else involved in the operation. The execution matrix should be modified as required.

PATRIOT BATTERY

This is the level at which most full-force rehearsals will be held. Full-force rehearsals might be conducted for special missions such as standoff jammer capability (SOJC), long-range engagements, or for missions in the far forward area when the battery is stripped down to the required launchers and support for mobility purposes. Strategic battery movements by air might require rehearsal to ensure that the battery can reach operational status

within a very short time after landing. As noted above, this rehearsal type should be preceded by a backbrief and reduced force rehearsals to properly prepare the unit leadership for the full-force rehearsal, and concluded by a complete AAR.

Using the on-line training mode (OTM) function of the Patriot system, mission-specific rehearsals for Patriot crews can be fashioned. Such simulations are flexible, immediately alterable, and reusable. They can be tailored to the specific mission, allow for alternative solutions, identify shortcomings in defense design, and be netted with the battalion ICC when the mission dictates.

CHAPTER 4

FORCE-PROJECTION OPERATIONS

Patriot units provide essential air defense of the force from the establishment of the lodgment through the termination of the contingency operation. Patriot's firepower and capabilities against both TBMs and ABTs make it an indispensable part of force-projection operations. This chapter discusses the role of Patriot battalions and batteries as part of the family of AD weapon systems in contingency operations. Also addressed are special planning considerations for Patriot during entry operations into a nonmature theater of operations. Figure 4-1 depicts ADA participation from initial lodgment operations through full-scale combat operations.

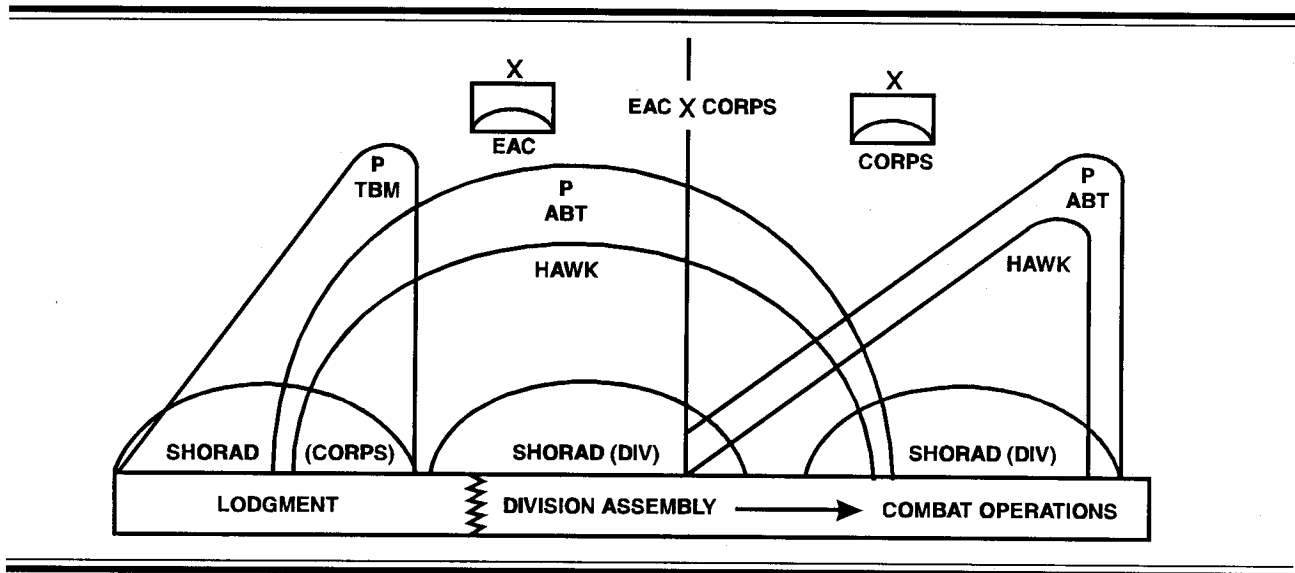

Figure 4-1. ADA force-projection operations.

APPLICABILITY

Contingency operations may require Patriot units to operate without a well-developed support base and to face a threat capable of attacking any point in the area of operations. The stages of force-projection

operations for Patriot units include pre-deployment activity, deployment, entry operations (establishment and expansion of the lodgment), operations, postconflict operations, and redeployment.

PREDEPLOYMENT ACTIVITY

Regardless of post and unit preparations and emergency deployment readiness SOPs in support of force-projection operations, Patriot battalion planners must plan each deployment individually. Planners must assess the threat, determine mission requirements, and phase Patriot deployment. The staff should use a reverse planning sequence. Operational requirements for a specific contingency will determine arrival times and sequences. Tactical requirements, the threat, and airlift capacity will be factors in determining exactly how the Patriot force will be packaged for deployment. These, in turn, determine the embarkation times and priorities. If a forced entry is required, US forces will organize into two echelons—an assault force and follow-on forces. Patriot planning must include provisions to provide air defense to forces.

THREAT

Air Force, Marine Corps, and Navy air elements may not initially achieve air superiority in contingency operations. Threat forces will attempt to gain the military advantage by disrupting and or destroying our ability to deploy forces into the theater. Threat air power and TBMs may be used to achieve these aims. Additionally, threat ground combat units along with special operations forces and airmobile forces represent a continuing threat to the lodgment area. The battalion S2 must conduct as thorough a predeployment IPB as possible.

COMMAND AND CONTROL

Air defense C² is critical to successful air defense of the lodgment. While C² is always a joint service effort for Patriot battalions, it is especially so during contingency operations. It

should be addressed in Patriot battalion mission plans and SOPs, and it must be flexible enough to adapt to different situations, equipment, and unusual US or allied command structures. The theater air operation in which Patriot participates will be planned and controlled by a JFACC designated by the joint task force (JTF) commander.

JFACC

Normally, the JFACC exercises operational C² of Patriot forces in two ways. First, procedural control is established through the use of AD procedures and rules of engagement (ROE). These also include air defense warnings (ADWs), weapon control status (WCS), self-defense engagement criteria, airspace control orders (ACOs), and air tasking orders (ATOs). These must all be developed specifically for the theater, and put into operation quickly to reduce the possibility of fratricide. Secondly, USAF components normally deploy with their organic C² facilities. This enables them to establish an air operations center (AOC), formerly the tactical air control center (TACC), with one or more subordinate control and reporting centers (CRCs). Using the CRC, the JFACC establishes positive control of Patriot fire by means of data link or voice transitions.

Command Relationships

Command relationships (Army, joint, and allied) are complex in contingency theaters due to their unique mission and ad hoc nature. The chances that all forces in the JTF have trained and worked together are remote. It is likely that allied forces have different and noncompatible equipment. In multinational forces, even something so basic as a common language may

not be available. Patriot commanders and staff officers must keep these facts in mind when

planning and executing Patriot air defenses in the lodgment.

DEPLOYMENT AND ENTRY OPERATIONS

Operations in a contingency theater will commence with air, sea, or land insertion of assault forces into the area of operations to establish a lodgment. Entry may be opposed or unopposed. Whenever possible, US forces seek unopposed entry, entering the theater peacefully with the assistance of the host nation. This lodgment provides a foothold through which further US forces and materiel enter a theater of operations.

Assault forces equipped with organic ADA elements will be directed to the defense of airfields and seaports, transportation centers, nuclear storage and delivery facilities (if they exist), C²I activities, and geopolitical assets when applicable (see Figure 4-2). A requirement for deploying Patriot into the theater at this stage would reflect the need for the firepower and capabilities Patriot units can provide. The theater threat may possess TBM and aircraft capabilities that require Patriot units or a HIMAD TF to be deployed early.

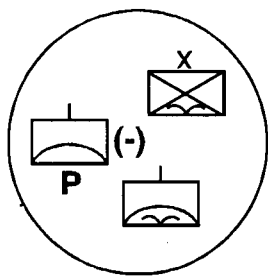

Figure 4-2. Establishment of the lodgment (example).

Patriot units should be deployed ahead of other units when the threat possesses TBMs that threaten the lodgment or possesses sufficient aircraft to overwhelm US and allied defensive counterair (DCA) capabilities. Commanders must balance the factors of METT-T against available airlift and sealift assets to determine the composition of the ADA force. For example, within the first few hours of entry operations, it may be necessary to put a Patriot minimum engagement capability on the ground. Three C-5 aircraft could transport an engagement control station (ECS), radar, electric power plant (EPP), two launchers with eight missiles, and 30 days minimum support for initial protection of the lodgment area.

As the lodgment expands and becomes better established with the arrival of more forces, ADA C² elements and further Patriot firepower are introduced into the theater (see Figure 4-3, page 4-4). This effort may likely employ Patriot units from EAC rather than corps ADA brigades. The initial mission of these Patriot units is to provide air defense of the first and most important theater asset, the lodgment itself.

Patriot elements may be airlifted, sea-lifted, or a combination of both. The Patriot FDC with its information and coordination central (ICC) should be considered a high priority and deployed as early as possible because of its capabilities to control the firepower of both Hawk and Patriot fire units, and because of its ability to communicate via data link with higher echelon control centers.

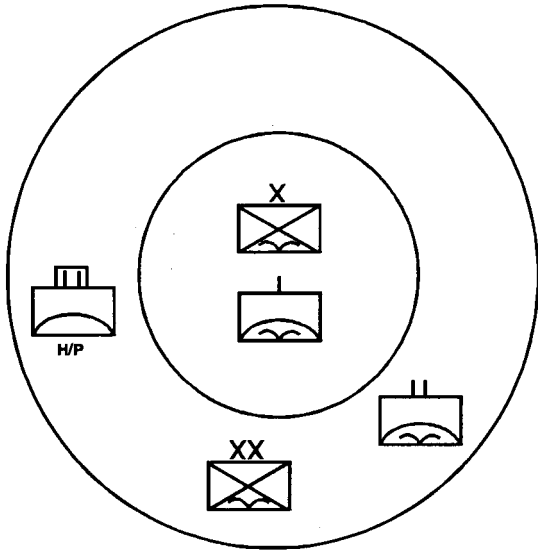

Figure 4-3. Expansion of the lodgment (example).

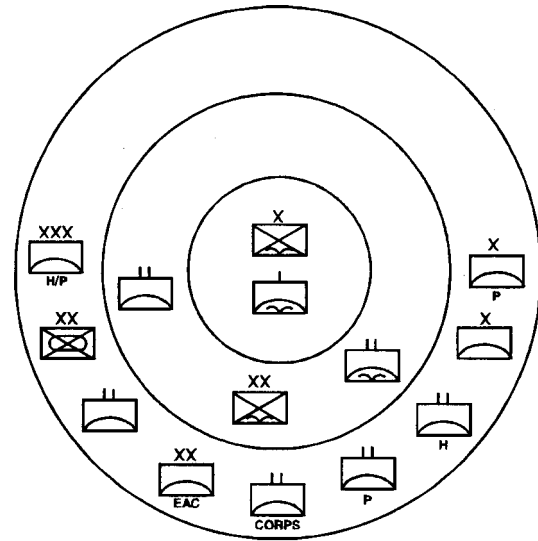

Figure 4-4. Continuing expansion of the lodgment /operation (example).

OPERATIONS

At some point during the expansion of the lodgment, the joint force commander will decide to move against the enemy. ADA units may have already begun the battle protecting the force and geopolitical assets from enemy TBMs, UAVs, and FW aircraft. EAC AD units may be augmented to provide

air defense to corps units while remaining under EAC control. While previously deployed EAC Patriot units continue to defend EAC priorities, corps assigned Patriot units may be deployed to the theater to provide air defense to corps priorities (see Figure 4-4).

WAR TERMINATION AND POST CONFLICT OPERATIONS

The goal of force-projection operations is a quick, decisive victory with minimum casualties. However, if the objectives of the deployed forces are not accomplished in a limited time frame, the theater may transition into a mature theater of operations. The lodgment will transition to support sustained, mature theater tactical operations. As the mature theater develops, added forces with their support and command, control, and communications (C³) elements will require Patriot defenses.

Successful termination of a contingency operation causes forces to transition to a period of postconflict operations. ADA units still provide vital force protection to prevent isolated attacks during this period. Selected ADA units, to include Patriot, may continue their presence in the theater as a deterrent and provide stability to the region. Based on METT-T, Patriot units may be among the last to withdraw.

CONSIDERATIONS

Patriot unit deployment, by air or sea, into a nonmature theater requires planners to package the force in order to meet available space requirements. Initial forces must be packaged to support the mission using the least amount of transportation space possible. Deploying batteries must be tailored with a self-contained balance of firepower and support. The number of launchers and support should be reduced to exactly what is required and no more. Essential repair parts and support equipment should accompany initial elements. Batteries must be capable of fighting and be self-sustaining until battalion support elements arrive. Planners should think imaginatively about what equipment is

needed or not. For example, if batteries initially deploy without the ICC to perform a TBM mission, there is no reason to send survey crews and equipment with them.

It is unlikely that Patriot units will deploy to an AO as a complete battalion. Some parts of the battalion may deploy by air, and some by sea. This requires a power-down approach to leadership to maintain control. Leaders at all levels must be able to perform with a minimum of guidance and a maximum of initiative. All equipment should be accompanied by at least one member of the unit to reduce the possibility that essential pieces might go astray during deployment or after arrival in the AO.

CHAPTER 5

OPERATIONS

This chapter discusses Patriot's offensive and defensive support operations. The role of Patriot battalions and batteries in both offensive and defensive operations is to shape the third dimension battle throughout the depth of the battlefield. This means not just protecting assets and maneuver forces, but disrupting enemy TBM and air operations from the rear areas to beyond the forward line of own troops (FLOT). Patriot offensive and defensive operations are driven by mission, commander's intent, METT-T, system considerations, and most specifically by the threat.

OFFENSIVE OPERATIONS

During offensive operations, Patriot's missions are to destroy incoming enemy TBMs and defeat enemy ABTs. To support an offensive ground operation, EAC Patriot may be deployed to augment the corps ADA brigade by protecting corps rear area assets. This allows corps ADA units to concentrate their efforts forward providing weighted protection to the corps' main effort. This may involve fighting Patriot as units or forming a HIMAD task force, depending on METT-T. In addition, forward-deployed Patriot units, belonging either to the corps or to EAC, influence the corps deep battle by augmenting corps and division ADA units with greater firepower and range. Patriot's ability to simultaneously engage large numbers of attacking aircraft, TBMs, standoff jammers, and specific aircraft at relatively long ranges, allows the ground commander freedom to execute the deep battle.

Patriot commanders should consider and plan for long-range engagements against enemy aircraft attack packages. While the Patriot system's probability of kill (P_k) may be comparatively low for such targets, the disruptive effect may be worth the expenditure of missiles, especially against a poorly trained or

motivated enemy. Such engagements must be sanctioned by the JFACC and coordinated through the air tasking order.

Patriot units should attempt to identify enemy aircraft packages, recognize the flight leaders, and selectively engage them, either before or during attack by friendly AD fighters. This type of engagement requires extensive coordination whenever possible, but such synchronization of effort will yield better protection of friendly units and assets.

Patriot units in the forward area should make the most of the system's capability against the jamming threat. Specific batteries should be designated for the mission of engaging standoff jammers, as this type of engagement reduces the system's ability to simultaneously engage aircraft and TBMs. For more details on SOJC engagements, see FM 44-85-1 (TBP).

PRIORITIES

Corps Patriot battalions and batteries providing air defense to offensive operations must thicken air defense over the corps' main effort to preserve the initiative. Top priorities

are providing protection to the maneuver units that form the main effort and to their support facilities such as critical operational and tactical assets, C³, logistics operations, and reserve forces. The Patriot battalion participates in the integrated theater air defense, which gives it access to early warning and intelligence information critical to the offensive effort and to the effectiveness of corps and divisional ADA units.

THREAT

Threat doctrine shows that the main objective of enemy air operations against our offensive operation is to destroy our ability to synchronize. The main threats to offensive operations that Patriot must counter are: the TBM threat that targets critical corps and theater assets as well as Patriot units themselves; the FW threat that attempts to target the same critical assets; and RW jammers and attack helicopters that penetrate short-range air defense (SHORAD) and Hawk units.

CORPS PATRIOT EMPLOYMENT IN THE OFFENSIVE

The supported commander's intent is the driving force for Patriot employment during offensive operations. Offensive operations during force-projection operations may be extremely fluid. Patriot units can expect rapid transition from defensive to offensive or to exploitation operations. Deep operations and rear area battles are likely to be conducted simultaneously. To support such fluid operations, Patriot must move quickly and efficiently to provide air defense of friendly attacking forces and their support base. When risk must be taken, battalion commanders may influence the battle by pushing the flow of missiles and fuel to batteries most likely to have a positive effect on the battle, while restricting the flow of those assets to batteries which are malpositioned or facing less opposition. Launching

stations may be directed from one unit to another to allow heavily engaged units to continue the fight. Repair parts and float equipment may also be used for the same effect.

Preplanning

An attacking force is most vulnerable to air attack during a movement to contact. Because Patriot units cannot shoot on the move, and move more slowly than other corps maneuver units, positioning must be planned in detail before the operation begins. Patriot coverage of highly mobile movements to contact can be maintained by several methods.

Forward coverage. Patriot batteries may be placed close to the line of departure (LD) for two reasons. This ensures that initial coverage can be maintained for at least several hours, and it places batteries in the forward area where they must beat the onset if they expect to be able to cover a mobile force when it contacts the enemy force. Once the force has crossed the LD, Patriot units must have priority for movement to ensure movement in a timely manner in order to provide coverage.

Detailed planning. Before the operation begins, the battalion S3 should identify, by map reconnaissance or other resources, as many suitable positions for Patriot batteries as possible along the axis of advance. Each battery should know in advance which sites it will most likely occupy, and when they should be operational. Actual use of these sites is dependent upon reconnaissance by the battery's reconnaissance, selection, and occupation of position (RSOP) team. For this reason, battery RSOP teams and battalion survey crews should be considered for placement with lead elements as a means to speed reconnaissance and selection of sites. Prospective locations for Patriot batteries should be coordinated through the ADA brigade S3, if possible, so that use of the land may be deconflicted with other corps units.

Leapfrog. Using the leapfrog method to move units forward ensures that Patriot coverage moves forward with the force. Initial coverage is provided by batteries located near the LD (see Figure 5-1). Designated batteries move forward behind attacking forces to preplanned positions along the axis of advance. When they become operational, the batteries at the LD move to forward positions, and so on, to the conclusion of the operation. This is a very difficult operation for Patriot units. Keep in mind these considerations:

- The number of Patriot batteries to be kept operational at any one time is dependent upon METT-T. The speed of the attacking force and the number of enemy aircraft and TBMs expected to oppose the attack are factors to be considered when determining the number of batteries to move at one time.

- Command and control of AD engagements during a highly mobile operation is extremely difficult. Prevention of surface-to-air fratricide must be a primary consideration. ROE for enemy aircraft must be clearly defined and widely disseminated. ROE of enemy missiles are less critical, but should also be clear and concise. Every source of target information data must be exploited fully.

- Patriot units cannot hope to provide TBM protection for attacking forces except at and just beyond the LD. TBM protection should be planned for CI nodes and for logistical locations, as these can be more readily defined, are not as mobile, and are more likely to be targeted by these weapons.

Focus

Patriot units must stay focused on the threat. When the primary threat is missiles, batteries must be placed near or with the assets being protected. However, when the primary threat is aircraft, this is not the case.

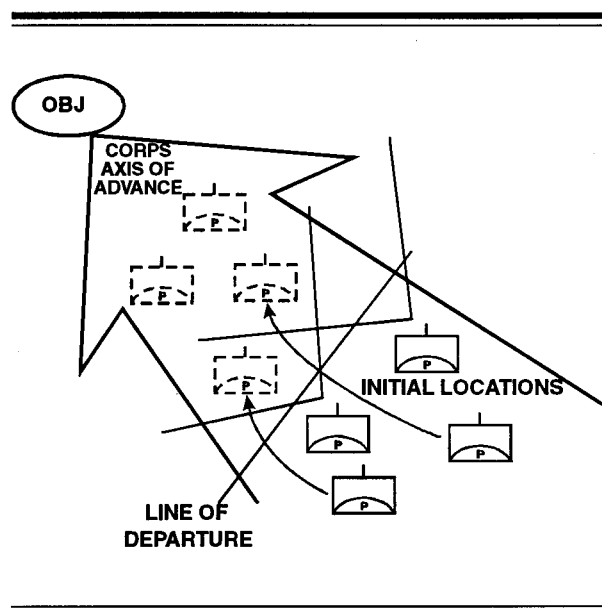

Figure 5-1. Leapfrogging Patriot batteries.

Planners should keep in mind the most likely AAOAs, as well as the locations of enemy airfields, when determining where to place batteries. Figure 5-2 (page 5-4) shows a possible placement of batteries to protect the flank of a corps movement to contact from air attack.

CONCLUSION

FM 100-5 states that successful offensive operations include the tenets of depth, synchronization, and agility. Patriot's contribution to offensive synchronization is to provide air defense to forces and assets at the critical time and place. This means that Patriot commanders and leaders must realize that agility is more often a state of mind rather than a simple matter of tactical mobility. Patriot's ability to look deep into the enemy's AO, simultaneously engage numerous threats at all altitudes, and react quickly to changing situations is the key to shaping the third dimension of the offensive battle.

DEFENSIVE OPERATIONS

The ultimate objective of any defensive operation is to seize the initiative from the enemy so that offensive operations may be mounted. Commanders must see Patriot's contribution to defensive operations as offensive in nature. Patriot units must aggressively attempt to disrupt the enemy's air campaign to the point that synchronization between air and ground offensive operations is not possible. Patriot battalions and batteries accomplish this by locating TBMs and ABTs, providing TBM and ABT protection to theater and corps critical assets, and by massing firepower forward against the ABT avenues of approach to those assets.

Long-range engagements, discussed earlier in this chapter, should be considered during defensive operations to help disrupt the enemy's offensive air campaign. However, this mission must be closely considered due to the low P_k , projected numbers of enemy aircraft and TBMs, and the number and types of available missiles.

Every effort must be made to synchronize Patriot fires with the Air Force or other service air defense aircraft. The threat of surface-to-air fratricide is greatly magnified during defensive

operations, especially if the enemy has enjoyed any success in targeting friendly C^2 structures.

THREAT

There are four major threats that Patriot battalions and batteries must counter during defensive operations to degrade the enemy's ability to synchronize. TBMs will target the lodgment area, C^2 nodes, and AD sites including air bases. FW aircraft will be programmed against the same targets. The ECM threat that targets not only ADA radars, but also C^2 nodes and communications in general, must be disrupted. Finally, Patriot must help corps and divisional ADA units counter the enemy's close air support (CAS) and battlefield air interdiction (BAI) operation that directly supports his ground operation.

PATRIOT EMPLOYMENT

Use of Patriot in defensive operations will differ depending on where the battalion is employed. The demands for rear areas differ significantly from those of forward areas.

Corps

Patriot forces in the corps area kill TBMs and aircraft directed against maneuver units and their sustainment facilities. These units also kill enemy aircraft attempting to penetrate to rear areas. Thus, Patriot units in forward areas must counter all the threats noted above. Forward Patriot battalions must also provide early warning for corps, division, and higher echelons, as well as integrate with Hawk and SHORAD fires.

Echelons Above Corps

Patriot, in areas controlled by EAC, must protect critical assets from TBMs and aircraft. Because Patriot's limited TBM capability forces prioritization of assets for TBM protection, not all

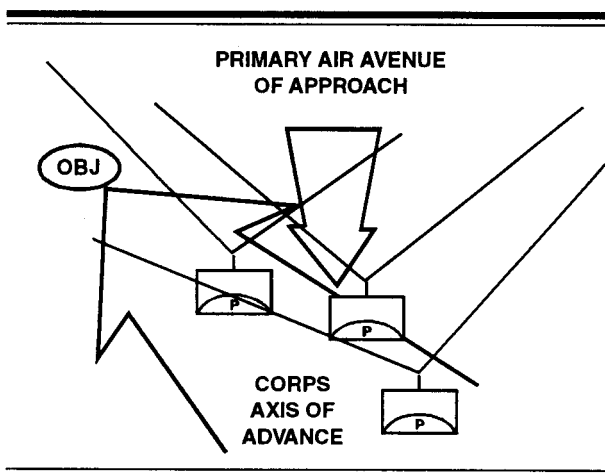

Figure 5-2. Focusing on the threat.

assets may receive the same degree of protection. Again, early warning must be exchanged with adjacent and higher echelon AD forces.

CONCLUSION

The challenge for Patriot units involved in defensive operations is twofold: first, to pro-

vide air defense to friendly forces facing air and missile attack, and second, to use their immense firepower and range offensively to help the air forces wrest the initiative from the enemy's air operation. If synchronization of the enemy's air and ground force is disrupted, the defensive battle can more easily be won.

ABT DEFENSE DESIGN

At the ADA brigade level, designing defenses is largely a matter of determining force allocation, task-organizing when appropriate, defining the zones and areas of responsibility within which subordinate battalions or task forces will operate, and constructing the C³ architecture to support the AD operation. At the battalion or task force level, defense design is the detailed process of maximizing Patriot system potential against the threat. It includes planning initial and follow-on positions, determining PTLs, allocating special missions to specific batteries, defining assets to be protected, and planning the necessary communications routing. The technical and system details of defense design are discussed at length in FM 44-85-1 (TBP) and in (S)FM 44-100A(U) (TBP).

At all levels, defense design is a continuous, iterative process. The battalion commander normally starts the process for his battalion by giving his guidance as a statement of intent and a concept of operations. Defense design is based on the following four possible missions for Patriot battalions:

- Pure ABT defense.
- Pure TBM defense.
- ABT-heavy defense.
- TBM-heavy defense.

Once guidance for concept of operation and intent have been specified, the battalion S3 begins the detailed work of defense design.

Batteries' locations, PTL designations, system initialization, and communications must be worked out. If the decision has been made to task-organize with Hawk, the S3 must also include allocated Hawk assault fire platoons (AFPs) into his defense design.

CONVERGENT PTLs

Because Patriot is a sectored system, the PTL is more significant than it was in the past with other systems. Conceptually, the fire units can be oriented so that their PTLs are convergent, divergent, or parallel.

Patriot fires are more effective against the ABT when convergent PTLs are used. As shown in Figure 5-3 on page 5-6, each Patriot battery's PTL converges on the PTL of at least two other batteries in the defense. Ideally, the PTL of each unit will converge on that of all other units in the battalion. Convergent PTLs are most effective when applied to known avenues of approach (AAs). Convergent PTLs are also effective against FW aircraft attempting to establish air corridors in forward areas. The exact orientation of battery PTLs depends upon the mission, IPB, and terrain. PTLs should be proposed by the brigade as part of the defense design process, but final PTLs have to be determined by the battalion as it deploys its batteries.

Convergent PTLs provide mutual support and defense in depth. They concentrate firepower to one area while sacrificing some of the additional area that could be gained by parallel or divergent PTL orientation. However, the protection provided by employing convergent PTLs can be sustained longer because it is less sensitive to loss of units than a deployment that uses parallel or divergent PTLs. More important, convergent PTLs make the Patriot system more effective against raids using escort or self-screening jammers by allowing the system to triangulate to provide range.

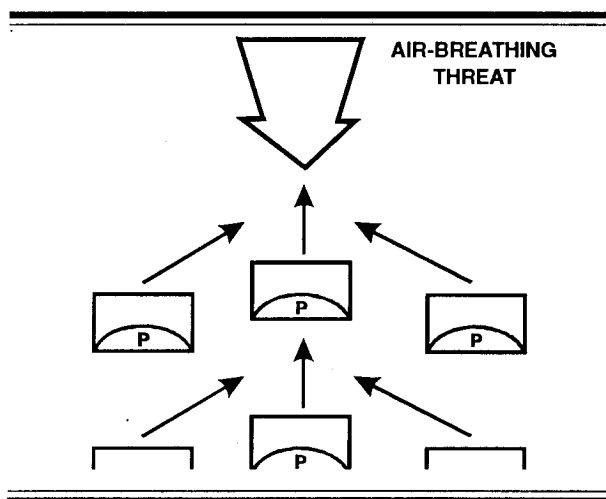

Figure 5-3. Convergent PTLs.

DIVERGENT AND PARALLEL PTLs

Against the ABT, divergent and parallel PTLs allow the battalion S3 to provide Patriot coverage to larger areas than when using convergent PTLs. This occurs at the expense of concentration of firepower and it reduces system electronic counter-countermeasures (ECCM) capability. However, in many circumstances, the considerations of METT-T will not allow the use of convergent PTLs. For example, if the battalion area of responsibility is

too large to allow batteries to be positioned using convergent PTLs, or if too few batteries have been allocated to the defense, then divergent PTLs may be required. When threat AAs require acquisition and firepower in different directions, the S3 may not be able to use convergent PTLs (see Figures 5-4 and 5-5).

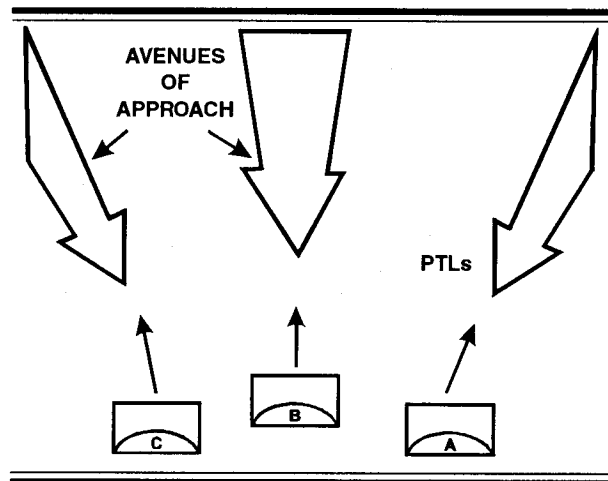

Figure 5-4. Divergent PTLs.

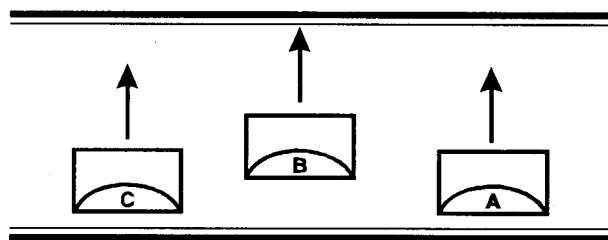

Figure 5-5. Parallel PTLs.

SECONDARY TARGET LINES

Secondary target lines (STLs) need to be carefully planned to sustain the AD protection of the supported unit or asset. They should also be planned for contingencies and to cover possible catastrophic failures. Launcher positioning must support the use of STLs. See FM 44-85-1 (TBP) for guidance on the positioning of launchers.

TBM DEFENSE DESIGN

When designing a defense against TBMs, convergent PTLs are not important to the overall design. Each battery's PTL should be oriented toward suspected TBM launch sites. It is important to remember that Patriot antitactical missile (ATM) capability is limited.

(S)FM44-100A(U)(TBP) addresses the technical details of a TBM defense, and FM 44-85-1 (TBP) addresses tactical software issues, but the S3 should follow these general guidelines:

- Plan for the "worst case." In other words, plan to fight against the most difficult TBM that the IPB indicates the enemy possesses.
- Overlap TBM coverage. Do this for mutual support between batteries and to thicken the defense by sharing assets between batteries. When possible, batteries should be placed within 20 kilometers of another battery to ease the planning process of sharing assets.
- Do not skew the ATM search sector. This should be done only when the TBM approach can be reliably identified as different from the main air AA.
- Place batteries as close to protected assets as possible. The rule of thumb is that the closer the battery is to the TBM ground impact point (GIP), the higher the P.
- Maximize the use of TBM surveillance. When the battalion's mission is providing asset

protection, two-thirds or more of the batteries should be in the TBM surveillance mode. In area defenses, one third or fewer batteries may be enough to provide sufficient protection.

- Distribute missile types relative to the threat. Attempt to ensure that at least four Patriot advanced capability (PAC)-2 missiles per battery are retained for self-defense in the likelihood that the enemy may use more than one wave of TBMs. Distribute PAC-2 missiles to more than one launcher so that the loss of a launcher has less impact on ATM capability. See FM 44-85-1(TBP) for further guidance on placement of missiles on launchers.

- Fight in the automatic TBM engagement mode. The system is designed to fight in the automatic TBM engagement mode. When the system has classified a target as a TBM, engagement decisions and the time in which the operator has to make those decisions are very limited.

- Identify the proper PTL for each battery with respect to the TBM threat. The closer a TBM flies to the PTL, the more reliable system engagement processing becomes. As a general rule, the closer the battery is to the TBM launch site, the more important the PTL selection is.

HIMAD TASK FORCE

The HIMAD task force (TF) is a mix of Patriot batteries and Hawk AFPs (the exact mix being dependent on IPB and METT-T) under the control of a Patriot ICC. Hawk AFPs normally operate centralized to the ICC in the same manner as Patriot FUs. The ICC is capable of controlling Patriot batteries and Hawk AFPs in a separate configuration, or of controlling subordinate battalions (Hawk and or Patriot through the BTOC or ICC, respectively). The size of the TF

is a function of METT-T and system capability (see Figure 5-6, page 5-8).

SOFTWARE CAPABILITIES

Patriot software limits the number of fire units that the ICC may control to no more than 12. Any combination of Patriot and Hawk batteries may be assigned to an ICC, as long as no more than 6 Patriot FUs are assigned. In the master ICC configuration, the ICC may also

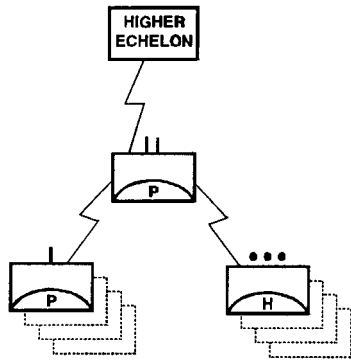

Figure 5-6. Task force structure.

control up to 5 subordinate battalions, though a task force that large would likely be beyond the ability of most ICC crews to control, regardless of the level of training. Such a large operation would also likely stress the communications capability of the organizations involved. Figure 5-7 shows the connectivity with higher echelon, auxiliary, lateral, and subordinate units, including the German Hawk Operations Center (GEHOC).

TASK FORCE CONSIDERATIONS

There are several general situations that require consideration for the use of a HIMAD TF:

- The corps or EAC commander wants to extend the ADA capability over his AI and into the deep battle in support of a tactical operation (for example, a deep air mobile assault). The long range of Patriot, coupled with the mobility of Hawk and under the central control of the ICC, provides the corps with effective air defense.
- When losses have been sustained, reconstitution of AD assets could call for the use of a HIMAD TF. When reconstituting, the firepower of remaining Hawk and Patriot batteries and AFPs may be consolidated under a Patriot ICC.
- In a nonmature theater, given the dual threat of TBMs and ABTs or possible movement constraints, the HIMAD TF may represent the best force package to defeat both threats. For example, Patriot batteries can provide protection of the lodgment area primarily against TBMs, while Hawk AFPs can be

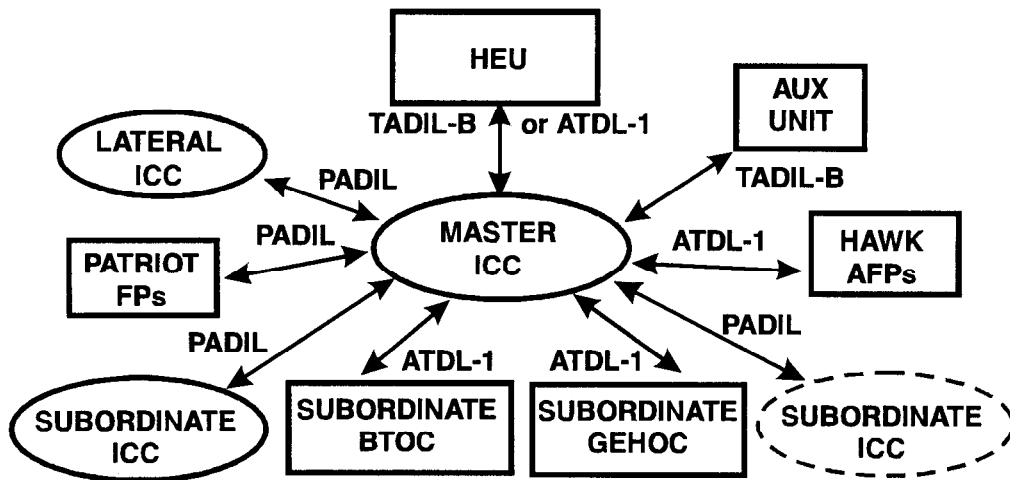

Figure 5-7. Master ICC configuration.

used to weight coverage, fill gaps, add EMCON capabilities, extend coverage, provide early engagement, and provide defense in depth against ABTs.

TASK FORCE INTEGRATION

In a task force configuration, the capabilities of the Hawk and Patriot systems complement one another and increase the effectiveness and survivability of both systems. To fully integrate operations, the Hawk system must be aligned with the Patriot survey crew equipment during the RSOP. Without precise integrated Hawk-Patriot alignment, target resolution will be ineffective, and accurate air battle management will be impossible. Differences in communications data languages complicate task force formation and make it imperative that Hawk and Patriot units conduct frequent interoperability training. Patriot uses PADIL for ICC and FU communications while Hawk uses ATDL-1. The ICC uses either ATDL-1 or TADIL-B for Hawk interoperability. Differences in track processing computers and data flow rate require modems in the ICC and CRGs to be used to integrate Hawk and Patriot systems. Tactical directors (TDs) and tactical control officers (TCOs) must train together often to understand requirements unique to the other system and be able to conduct operations smoothly. The system specific languages and system capabilities are divergent enough to cause confusion during the pressure of battle.

Phase III Hawk

The Phase III Hawk system makes integration with the Patriot ICC much easier because the data displays, mapping, and internal software are modeled after Patriot's. Figure 5-8 shows a HIMAD task force defense with Hawk augmenting Patriot coverage by providing rear and side coverage for the Patriot dead

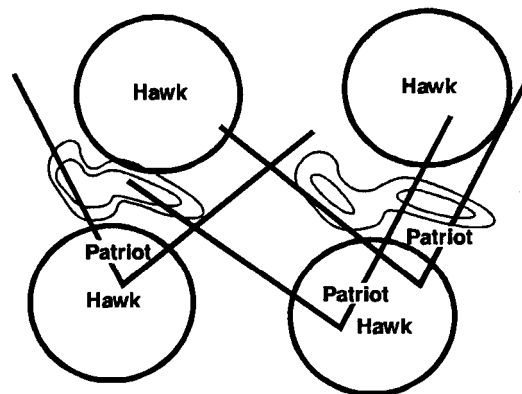

Figure 5-8. HIMAD task force.

zones. Two AFPs also provide early engagement and defense in depth to counter ABTs and conserve Patriot missiles for more threatening targets such as TBMs.

Planning Factors

To fully implement the concept of the HIMAD TF, the task force S3 must not only understand both the Patriot and the Hawk systems, but must also have a good working knowledge of the software of both systems and its impact on the planning and execution of the mission. The TF commander must also have a thorough understanding of the capabilities, limitations, and requirements of both systems. Planners should refer to (S)FM44-100A(U) (TBP) and FM 44-85-1(TBP) for technical details and specifics on both systems.

TASK FORCE ADVANTAGES

The formation of a HIMAD TF can afford the commander several advantages.

Mix

By combining the two systems under the ICC, the limitations inherent in each system are to some extent mitigated. For Hawk, track

correlation is improved, identification conflicts quickly resolved, and the P_k and survivability are enhanced. For Patriot, existing sector coverage is augmented and dead zones are filled. When Hawk AFPs are placed forward of Patriot batteries, they may provide early warning to the TF and may also be able to drive attacking aircraft up into Patriot fires. In any case, enemy pilots are forced to fly against two systems that use two very different methods of acquisition and guidance that share a single C² node. Hawk survivability is enhanced, and if the defense is properly designed and operators are properly trained, both systems will be engaged fully.

Economy of Force

Better use of available missiles is more easily accomplished under TF C². A coordinated effort allows for a more judicious use of Patriot missiles which are more expensive and less plentiful than Hawk missiles and might better be conserved for use in the TBM role. Placement of Hawk AFPs to support early engagement by Hawk and training Patriot TDs to favor use of Hawk over Patriot are fundamental to making the HIMAD TF function efficiently (see FM 44-85-1[TBP]).

Agility

The HIMAD TF provides the force commander with a means of tailoring the AD organization to fit the combat situation and the mission. The TF is a multifaceted organization that can counter the entire spectrum of potential threats facing the corps and EAC (for example, FW and RW aircraft, TBMs, and jammers). Use of Hawk with Patriot frees up Patriot for the ATM role and for missions against standoff jammers. Patriot's communications capabilities provide the TF with robust, reliable communications. Patriot can increase Hawk survivability by providing high-quality early warning via

data link as well as by providing incidental TBM coverage. Hawk's greater mobility can allow the TF to provide good coverage during highly mobile operations. When fire units are available, the TF organization lends itself easily to change. As the brigade commander alters the TF structure, units may be added or taken away to meet fluid situations.

Synchronization

The coordination of effort that the HIMAD task force allows provides unprecedented synchronization, and, therefore, greater effectiveness and lethality on the battlefield. During the planning for contingency operations, the TF may also provide planners with flexible means for providing ground forces with adequate TBM and AD protection. Limited airlift assets require planners to put together force packages that provide a maximum of firepower while costing as little as possible in weight or numbers of aircraft sorties. Pure Patriot or pure Hawk configurations may meet the requirements of METT-T in some circumstances, but many potential contingency operations may need the flexibility that the TF provides in terms of firepower against both the TBM threat and the ABT.

TASK FORCE DISADVANTAGES

The disadvantages of the HIMAD task force revolve mainly around training and support issues. The effects of both may be mitigated by ensuring that mission-essential task lists (METLs) for both types of units include the task force mission and by ensuring that unit tactical SOPs address the formation and composition of task forces. The ADA brigade is primarily responsible for ensuring that SOPs of assigned Hawk and Patriot units are compatible and that they support task organization. Training objectives which emphasize the formation and proper support of

task forces will result in units that can fight together.

TRAINING THE TASK FORCE

Training issues for the HIMAD task force include tactics and communications training. Patriot tactical directors and assistants must be thoroughly familiar with the Hawk weapon system. They must understand how Patriot system software functions with regard to Hawk.

Operations

On the Hawk side, tactical control officers and radar operators must understand the differences in C³ when linked to the ICC (see FM 44-73). In many cases, these are no more than differences in terminology, but unless they are identified and understood, they can severely affect the synchronization that is the strength of the HIMAD TF. Hawk TCOs at the battery level will need more than brief familiarization with the Patriot system to fully integrate operations and deconflict engagements at the battery level. During task force operations, it is particularly important that the operators and planners in both systems fully understand the capabilities, requirements, and limitations of the other system to synchronize AD operations.

Communications

Training for both Hawk and Patriot communicators is critical. Compatible communications SOPs which stress channelization for UHF systems will reduce unnecessary training. Patriot communicators should be familiar with the communications equipment used by their counterparts in the Hawk units. Many of the differences amount to no more than terminology. Training together frequently will increase understanding and ease integration of the TF.

Logistics

Providing the right slice of system-specific support to the HIMAD TF is a difficult problem. Unit SOPs that address this subject should be based upon solid evidence gathered during TF training. Training should be structured to stress the logistical system. SOPs should address how support is to be accomplished; how repair parts are to be divided, and how maintenance personnel, tools, and test equipment are to be allocated. While the emphasis here is on system support, variations in conventional and communications equipment between Hawk and Patriot units must be considered as well.

TF DEFENSE DESIGN

During TF defense design planning, Patriot deployment should be considered first to lay the framework for the defense. Hawk AFPs should then be factored into the design. Normally, Hawk AFPs should be emplaced within the Patriot sector 10 to 20 kilometers forward of FUs in valleys, along low-altitude AAs, or areas not sufficiently covered by Patriot. This will ensure that the Patriot air picture provided to Hawk will be of use, and that Hawk can detect low flyers in Patriot dead zones. Hawk detection will force aircraft up into Patriot coverage.

Organization

When a TF is organized, it should consist of no less than three Patriot batteries. This will help ensure that the TF will retain good ECCM capability through triangulation. Although METT-T will help determine the exact size of the TF, a mix of four Patriot batteries and four Hawk AFPs is a good baseline. This facilitates excellent area coverage and is well within the workload capacity of well-trained ICC operators. It also facilitates assignment of remaining Hawk units, eases system-specific support

problems, and maintains Hawk battery administrative and logistics integrity.

Employment

When necessary, Hawk can be employed on the flanks and rear of the Patriot defense, preferably within Patriot coverage because of the reasons stated above. When this is not

possible, the S3 should ensure that Hawk AFPs do fall within Patriot sectors after reorientation to Patriot STLs.

Planning Tool

Table 5-1 is a mission-to-task force organization matrix. This is a general template for planning or brainstorming purposes; it is not intended

Table 5-1. Task force matrix.

	HIMAD FORCE CONFIGURATION	PURE HAWK	PURE PATRIOT	PATRIOT HEAVY TF	HAWK HEAVY TF
MISSION	DEFENSE	4	2	1	3
	OFFENSE	2	4	3	1
	EXPLOITATION	1	4	3	3
	CONTINGENCY	4	2	1	3
ENEMY	INDEPENDENT AIR	4	2	1	3
	TBM	NA	1	2	3
	FRONTAL FIXED WING	3	4	1	2
	ATTACK HEL REG	1	4	3	2
	SOJC	4	1	2	3
TERRAIN/ WEATHER	HILLY	2	2	1	2
	FLAT	3	4	1	2
	MOUNTAINOUS	4	3	1	2
	POOR TRAFFICABILITY	1	4	3	2
	POOR ROADS	2	4	3	1
TROOPS/ EQUIPMENT/ RESOURCES	FIREPOWER	3	1	1	2
	TRANSPORTABILITY	1	3	3	2
	SUPPORTABILITY	1	1	2	2
TIME	HIGH MOBILITY	1	4	3	2
	RELATIVELY STATIC	4	2	1	3

to be prescriptive in nature. In this matrix, 1 is the first choice and 4 is the least desirable option. The numbers may be altered to fit any situation.

To understand the logic behind this matrix, one must understand the advantages and disadvantages associated with each type of task organization. A Patriot-heavy TF consists of more Patriot batteries than Hawk AFPs. A Hawk-heavy TF consists of more Hawk fire AFPs than Patriot batteries.

Separate battalions (pure Hawk or Patriot).

- **Advantages.** It is much easier to train and to sustain logistically than a HIMAD task force. C² is simpler. No interoperability is required. Patriot and Hawk units deal only with their normal command, control, and logistics channels. Early in the initial deployment, pure units may be the only practical solution to the deployment requirements.

- **Disadvantages.** There is no mix of weapon systems so there is no compensation for inherent limitations. Hawk has a limited capability against TBMs and Patriot lacks a 360-degree defense capability.

Patriot-heavy task force (more Patriot batteries than Hawk AFPs).

- **Advantages.** Attached Hawk platoons provide protection for Patriot's rear areas, flanks, and dead zones. This allows for the maximum use of Patriot's system capabilities to cover its area of responsibility. It enhances Hawk's track correlation and identification. Hawk also receives TBM protection and increased remote air picture.

- **Disadvantages.** Sustainment of Hawk elements in the TF poses problems. Repair parts cross-leveling and maintenance actions may be complicated and slow. Training is required. A further disadvantage is the diminished mission for the Hawk battalion commander and his staff.

Hawk-heavy task force (more Hawk AFPs than Patriot batteries).

- **Advantages.** It is more mobile in some theaters than other task organizations,

except for pure Hawk. Patriot batteries provide overwatch protection. It is extremely effective against fixed- and rotary-wing support. Hawk survivability forward is greatly increased due to TBM protection received from the Patriot battery.

- **Disadvantages.** Sustainment of reduced numbers of Patriot batteries poses the same problems that Hawk has with the Patriot-heavy force. Patriot faces decreased survivability due to smaller number of Patriot batteries. When a TF is formed in the corps ADA brigade, it takes the only ICC. If the TF is commanded by the Hawk battalion, Patriot batteries not assigned to the TF may be left without direct C² due to lack of an ICC (current tables of organization and equipment [TOEs] carry one ICC per corps ADA brigade). The Patriot battalion commander and his staff face the same lack of mission as the Hawk battalion commander and his staff face in a Patriot-heavy battalion.

ALIGNMENT

Hawk alignment in the pure configuration normally uses map spotting or resection with the M2 aiming circle to orient the AFP. This provides sufficiently accurate data for the correlation needs of the Hawk BTOC. However, when operating with Patriot, these alignment procedures are not precise enough to ensure track correlation and rapid lock with the Hawk high-powered illuminator (HPI). In a TF, survey crews assigned to Patriot must be sent to subordinate Hawk AFPs as they move about the battlefield to provide location, altitude, and alignment data. This may create a management and coordination problem for the TF S3 because of the limited numbers of survey crews assigned. However, the Patriot quick response program (QRP) with the global positioning system (GPS)/precision light-weight GPS receiver (PLGR) helps to alleviate some of the management and coordination

problems for the TF S3. Unit moves must be coordinated so that survey crews can be

available to RSOP teams before the main body closes.

DEFENSE DESIGN RECOMMENDATIONS

Defense design begins with the commander's guidance. The following figures show several possible designs for pure Patriot and or TF. These are only examples to be used as a start. Each unit must, of course, tailor these designs to its own structure and specific mission.

PURE TBM

Figure 5-9 shows a possible defense design for a TBM pure defense. The specific priorities for a pure TBM defense must be articulated and well-defined because of the limited nature of Patriot's TBM capability. EMCON must be addressed. PTLs will be oriented on the source of the TBM threat. ABTs are engaged only as directed by higher authority and if it does not detract from the primary mission of killing TBMs. Batteries should be placed no farther than 20 kilometers apart when the mission

allows. Defended assets should normally be as close as possible but no farther than 20 kilometers from the battery.

PURE ABT

Figure 5-10 shows a possible defense design for a pure ABT mission. In a pure ABT defense, Patriot batteries should be arrayed to provide air defense to assets and forces as dictated by the mission analysis and prioritization process. Mission permitting, PTLs should converge whenever possible. This defense lends itself well to task organization with Hawk. Batteries should be placed no farther than 20 to 30 kilometers apart. Defended assets should be no farther than 30 kilometers from the battery. Dependent on METT-T, the Patriot ICC may initialize Hawk AFPs as defended assets.

TBM-HEAVY

Figure 5-11 shows a possible defense design for a TBM-heavy mission. When arrayed in a TBM-heavy defense, Patriot batteries should focus on providing effective fires against TBMs, but they must consider the ABT as well. PTLs should be oriented on the TBM threat, STLs on ABT avenues, and planners should keep in mind the shorter acquisition range of the Patriot radar against the ABT when in the TBM search mode. This defense should be considered when deploying Patriot as a TF, and it is especially useful for contingency operations when the threat of both TBMs and ABTs exists. Batteries should be placed no farther than 20 kilometers apart. Defended assets should be no farther than 20 kilometers from the battery. Dependent on METT-T, Hawk AFPs may be designated defended assets.

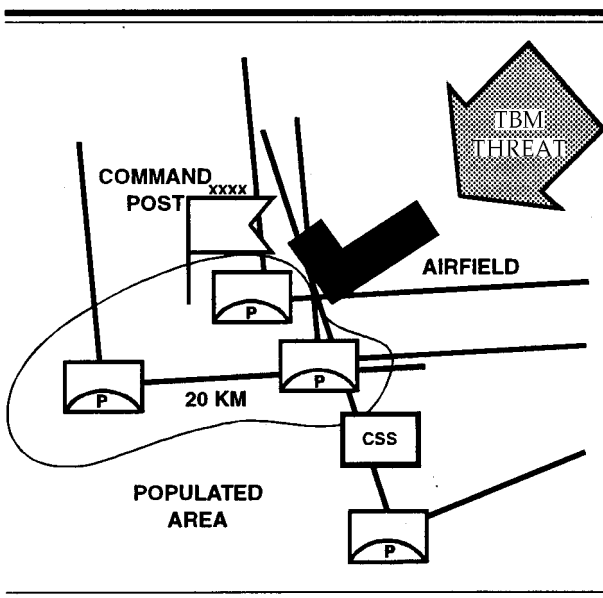

Figure 5-9. Pure TBM defense.

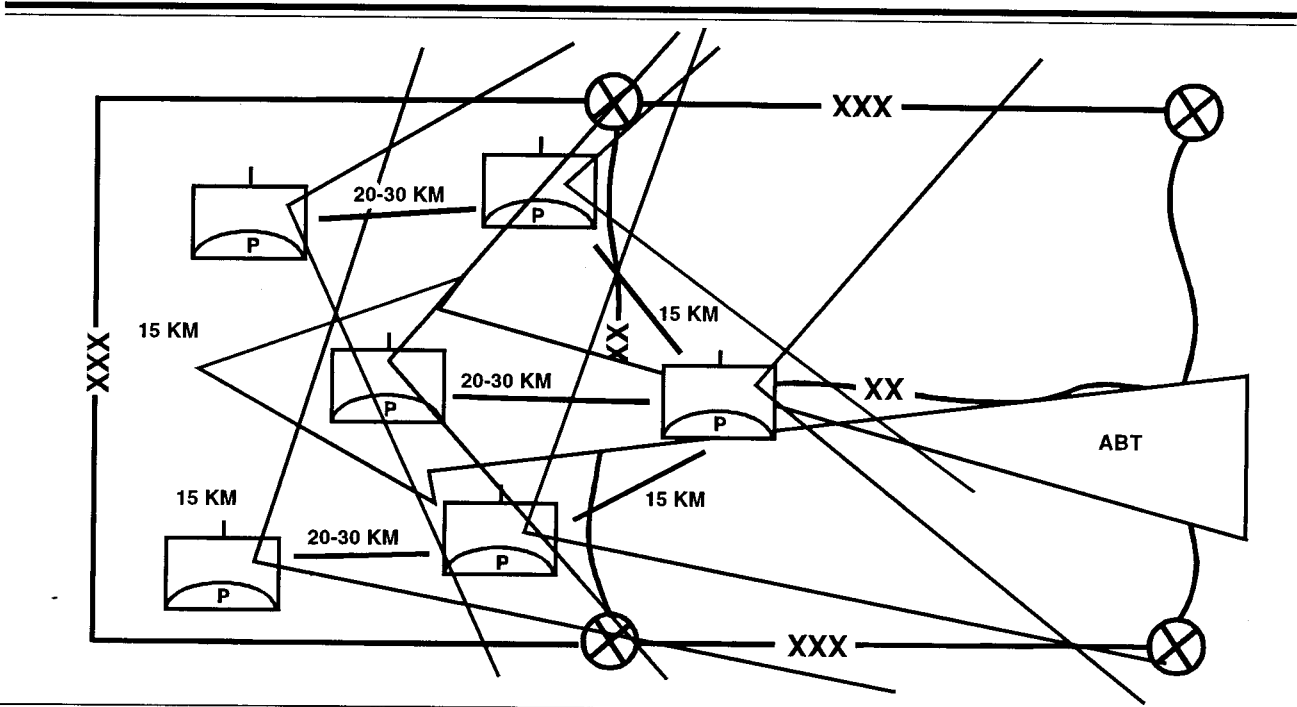

Figure 5-10. Pure ABT defense.

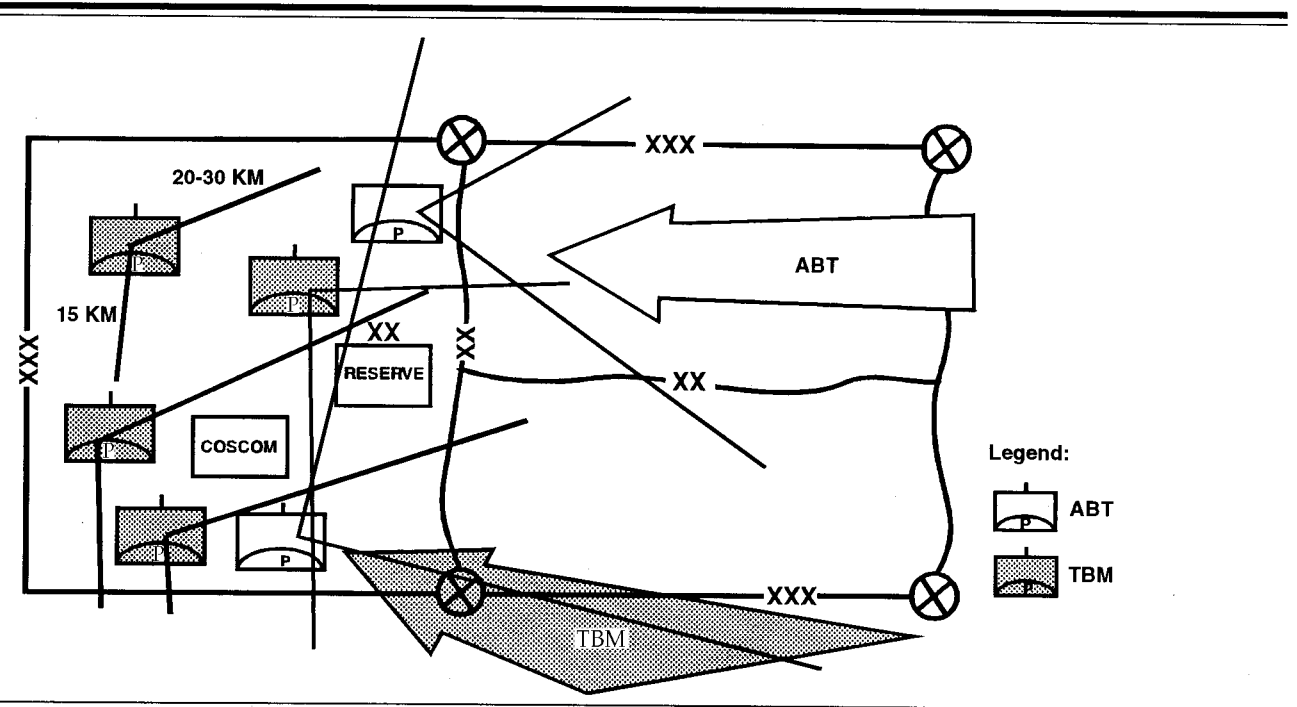

Figure 5-11. TBM-heavy defense.

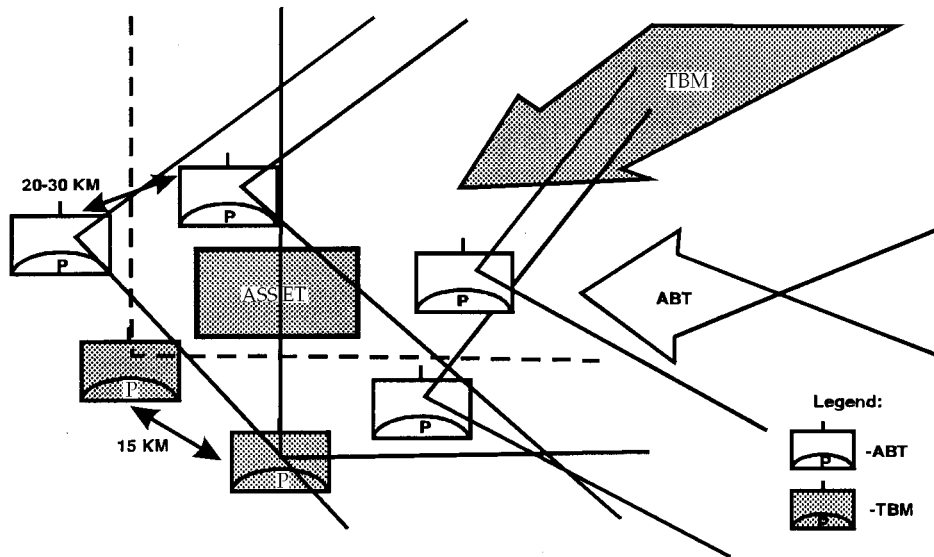

Figure 5-12. ABT-heavy defense.

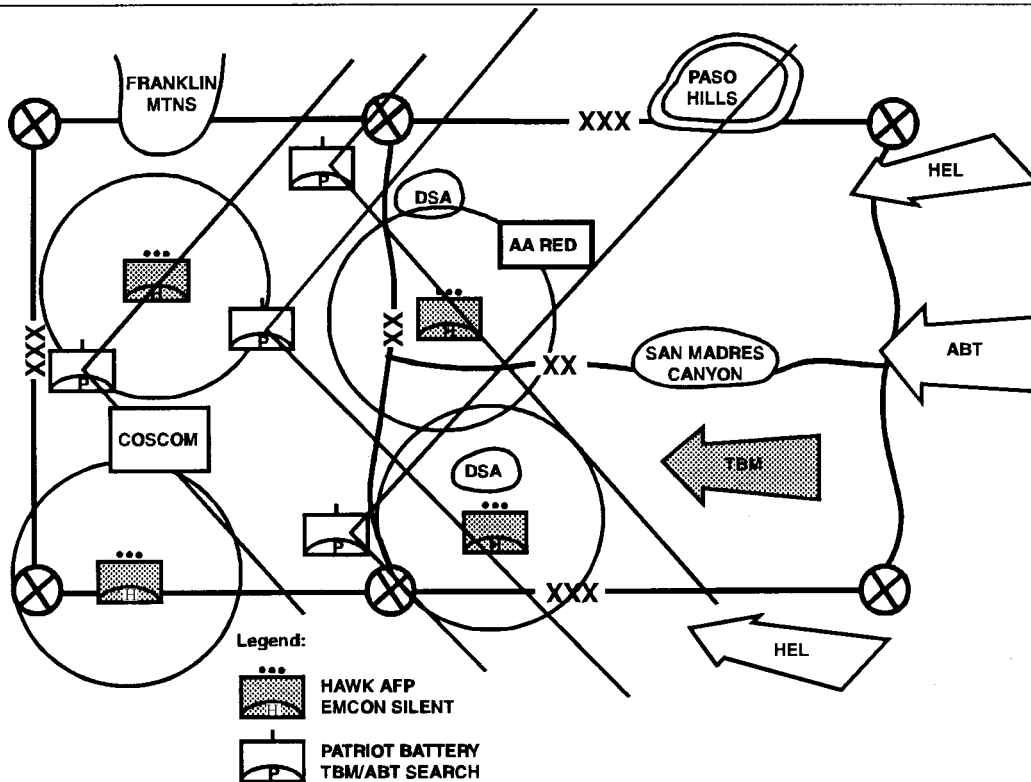

Figure 5-13. Task force defense design, ABT-heavy mission.

ABT-HEAVY

Figure 5-12 shows a possible defense design for an ABT-heavy mission. The priority for an ABT-heavy defense is to kill enemy aircraft. This defense would be used when the threat of TBM attack exists, but the major threat is by ABTs. The defense design should be oriented on the ABT, PTLs should converge whenever possible, and assets designated for TBM protection must be clearly defined so that one or two batteries may be allocated to the antitactical ballistic missile (ATBM) mission. Batteries should be no farther than 20 kilometers apart for TBM and 30 kilometers for ABT.

TASK FORCE DEFENSES

The HIMAD TF defense design is determined by the unit's mission rather than location. The TF defense design relates to three of the Patriot system's four missions. To reiterate, those missions are—

- ABT-heavy defense.
- TBM-heavy defense.
- Pure ABT defense.

The exact task force configuration and deployment should depend on the mission of the entire force, supported force goals and objectives, and threat capabilities. Brigades should design and train for TF operations that support their mission(s).

The following designs are examples of proposed task force missions. A TBM as well as an ABT is assumed. A standard task force of four Patriot batteries and four Hawk AFPs is used.

ABT-Heavy Mission

The ADA TF commander's intent is to identify and destroy enemy jammers, counter TBMs, and provide the maneuver force with protection from FW and RW attacks (see Figure 5-13). Tactical surprise and mobility are the keys to success. Hawk AFPs are positioned forward of Patriot units to cover dead

space. Hawk is EMCON silent until required to radiate. Patriot provides an air picture to Hawk. Patriot is positioned to the rear of the corps sector to defend designated assets. Patriot PTLs for the two rear batteries are directed toward the TBM threat. The forward batteries cover the main ABT approach and provide acquisition and fires for the standoff jammer (SOJ) threat.

TBM-Heavy Mission

In Figure 5-14 (page 5-18), the TF commander's intent is to provide a lodgment with protection from TBM and air attack. Clear definition of assets for TBM protection and area coverage by Hawk are the keys to success. Hawk AFPs are positioned to the flanks and rear of Patriot units to cover the out-of-sector area. Hawk is EMCON silent until directed to radiate. Patriot provides air picture to Hawk. Patriot is positioned behind the lodgment with respect to the TBM threat, PTLs for rear batteries are directed toward the TBM threat. Forward batteries provide protection against the main ABT avenues of approach.

Pure ABT Mission

In Figure 5-15 (page 5-18), the TF commander's intent is to identify and destroy enemy jammers and provide the maneuver force with protection from air attacks. Mutual support and overlapping fires are key to success. Hawk AFPs are positioned forward of Patriot to counter the helicopter threat and to the flanks and rear to cover dead space. Hawk is EMCON silent until required to radiate. Patriot provides the air picture to Hawk. Patriot is positioned to the rear of the corps sector to defend designated assets. Patriot PTLs converge for maximum firepower over the defended area and to assist system capability against jammers.

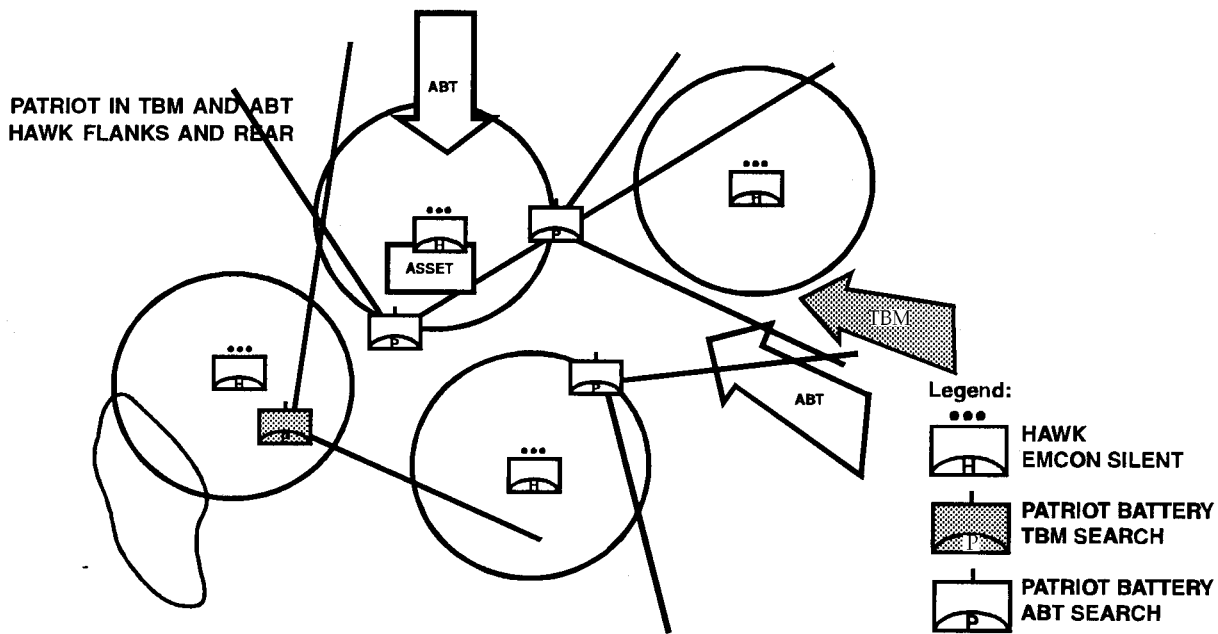

Figure 5-14. Task force defense design, TBM-heavy mission.

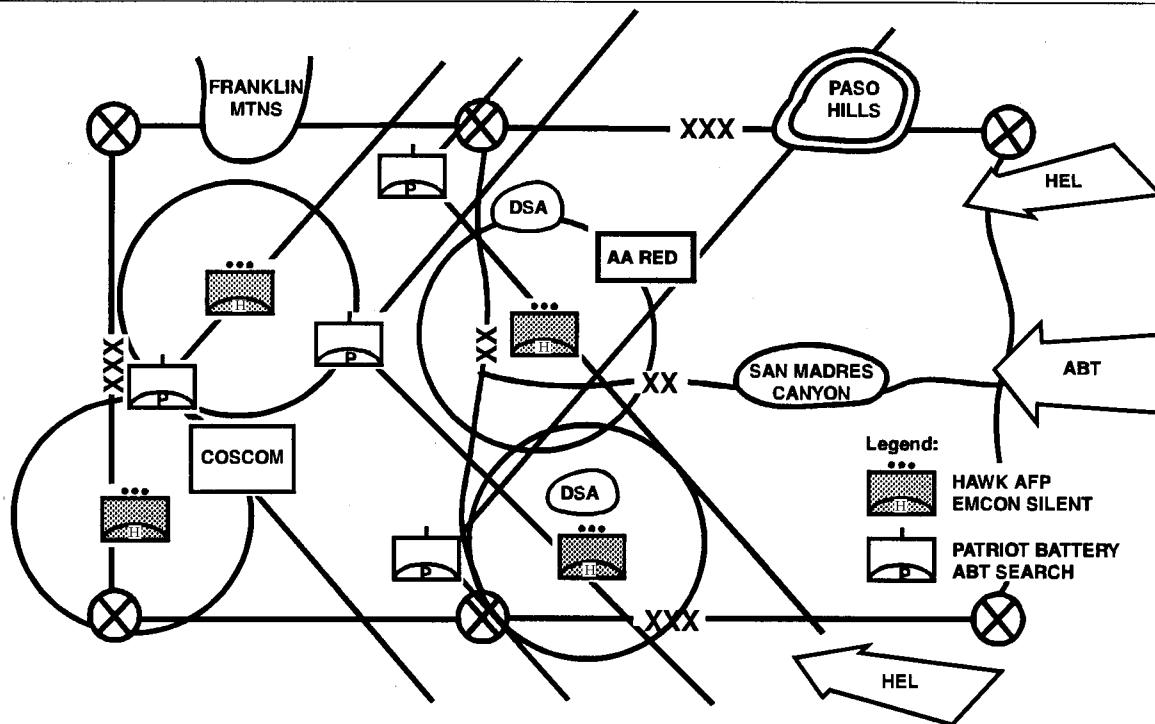

Figure 5-15. Task force defense design, pure ABT mission.

COMMAND, CONTROL, COMMUNICATIONS, AND INTELLIGENCE

The ability of a Patriot unit to function effectively on the battlefield depends on effective C³I. The following are definitions of each element.

COMMAND

Command is the authority that a commander exercises over his subordinates. It includes the authority and responsibility to use available resources to accomplish the assigned mission as well as to plan the employment and organization of the unit. It also includes the responsibility for the health, welfare, morale, and discipline of assigned soldiers.

CONTROL

Control is the authority, which may be less than full command, exercised by a commander over the tactical activities of a subordinate unit. Patriot's control chain sometimes functions separately from the command chain. For example, in USAREUR, theater HIMAD is controlled by the Air Force's central region rather than the brigade and Army AD command chain.

COMMUNICATIONS

Communications are the key to effective C². The two basic types of communications are voice and data. Communications are covered in detail in Appendix G of this manual, and also in FM 44-85-1 (TBP).

INTELLIGENCE

Intelligence, in the context of C³I, involves the gathering and processing of target information and early warning. Some of this information is available via Patriot's data links, while some is passed by voice. This type of information directly affects engagement operations in that most of it is information about the identity and proximity of airborne targets. It allows Patriot units to identify friendly aircraft, helps

identify hostile aircraft, provides early warning for enemy missile attacks, and aids in target selection and prioritization.

COMMAND AND CONTROL FACILITIES

There are three types of Patriot C³I facilities: command post (CP), fire direction center (FDC), and tactical operations center (TOC).

Command Post

The CP is the command and control center of the unit. The unit commander is normally located at or near the CP. CPs are maintained at both battery and battalion levels. The CP controls the unit ground defense control cell, battery Stinger teams, logistics functions, the administrative communications networks, and other unit operations activities.

Fire Direction Center

The FDC is the air battle control facility for the Patriot battalion. It consists of the Patriot ICC and support equipment. FDC operations are controlled at the tactical level by tactical directors and their assistants who operate the ICC. The unit tactical communications nets are routed through the ICC for air battle control.

Tactical Operations Center

TOCs are located at all echelons which are authorized a staff. The battalion TOC is the operational control and planning center for the battalion. The TOC provides guidance to the subordinate unit commanders on employment, organization, and intelligence. In some situations, the TOC may be split into operations and logistics cells located in different areas. Normally, the S3 is in charge

of the operations, planning, and intelligence cell. This cell also normally handles most Patriot system specific logistics requirements. The administrative and logistics cell, under the direction of the battalion executive officer, handles administrative and personnel matters, and most logistics functions and coordination (see Chapter 6).

AIR DEFENSE C²

The three cornerstones that form the basis for AD C² are discussed in the next paragraphs. For a more complete discussion of C², see FM 44-100.

Centralized Management and Decentralized Execution

Because of the complexity of force projection, air battle management must be centralized at the highest possible level to ensure synchronization of effort and combat power. However, the sheer volume of operations precludes an efficient response at the highest air battle management level. Execution at the lowest possible level ensures rapid and flexible response within the guidelines set by higher levels. Whenever friendly air forces maintain air superiority, Patriot units can expect the JFACC/AADC to exercise tight centralized control of Patriot firepower to preclude fratricide.

Air Battle Management

This is the control and coordination of both tactical air-to-air and surface-to-air defense resources. Close coordination is vital to the

integrated AD activity due to the many systems and components of the defense. Mutual interference and fratricide must be prevented. There are two basic methods for air battle management. They are positive control and procedural control. Some combination of both methods is the most effective solution. The specific mix is determined by a number of factors. The nature and magnitude of enemy operations, and terrain and weather conditions will affect the balance of management. The availability, capability, reliability, and vulnerability of the management facilities, and the number, deployment, and characteristics of friendly airborne weapon systems impact on the management method choice. The electronic identification capabilities will determine the amount of positive management procedures used. The challenge for leaders of Patriot units is to understand how procedural control is implemented in their weapon system, and to be able to convert that understanding into permission to engage using procedural controls. As noted above, loss of air superiority, or failure to gain air superiority, will stress our ability to use positive control. Use of procedural control by Patriot units must not make bad situations worse by causing fratricide.

Management by Exception

This is the case-by-case management of engagements. Rather than try to direct every engagement, air battle controllers will prevent prohibited engagements. This reduces the detail down to a manageable level at each level of control.

REMOTE LAUNCH

Remote launch (RL) use in defense design is a battalion-level decision due to the increases in logistics and security support. The battalion may

now task-organize its FUs or design its defense to give one or more batteries additional remote launchers for TBM protection of remote assets.

QRP HARDWARE AND SOFTWARE

Hardware and software improvements provide additional flexibility in defense design by allowing a TBM defense to protect more assets with a higher P_k .

IMPROVED FIRE UNIT SURVIVABILITY

An FU does not have to deploy on an asset (as in post deployment build [PDB 3]) to afford the greatest protection to the asset. Assets can be protected by an RL section or platoon.

EMPLACEMENT

Automatic emplacement enhancement (AEE) makes the emplacement of the Patriot system an automatic procedure, reducing the requirement to schedule use of survey crew equipment. It provides an all-weather, day and night emplacement capability. However, the survey crew, the M1 gunner's quadrant, and the M2 aiming circle must be retained by

Patriot for the following circumstances:

- Emplacement capability when the AEE system is unable to function (that is, insufficient number of satellites).
- Position data for LSs during mixed mode employment.
- Data for a minimum engagement capability during movement.

CHAPTER 6

PATRIOT COMBAT SERVICE SUPPORT

This chapter provides the doctrine for the combat service support (CSS) of Patriot battalions and batteries. It further discusses CSS provided by the corps support command (COSCOM) and the Theater Army Area Command (TAACOM) to provide an understanding of how they provide support to Patriot battalions assigned at corps or EAC.

To be successful, an concept of operation must be logistically supportable. The battalion commander and his staff must ensure that logistics is an integral part of the total battalion operation planning process. In determining the best COA, the commander must be fully aware of the logistics constraints and limitations, and adjust his COA, or accept the risks entailed by not doing so. Examples for the task organization resources and assets are included to ensure proper understanding but are not the only method to support the mission. Comprehensive details on logistics are in FMs 44-100, 54-30, 63-3, 63-4, 100-10, and 100-16.

PATRIOT SUPPORT CONCEPT

The logistics concept for the Patriot battalion embodies the principles of responsiveness, flexibility, and initiative. Force-projection operations require that supporters anticipate needs and not wait and react to demands. Central to the ability to do this is constant coordination and detailed planning between supporters and those supported. Battery commanders and the battalion supply officer (S4) must understand the battalion commander's intent to perform responsively. Close coordination with the battalion operations and training officer (S3) is necessary to ensure that batteries with the highest tactical priority receive required

support first. Ammunition and bulk fuel resupply, direct support maintenance, personnel replacement, and medical evacuation are requirements with the highest priority depending on the tactical plan. Each Patriot FU is totally self-sufficient.

The combat mission of the battalion and batteries remains the foremost consideration in carrying out logistics functions within the battalion. Resources and priorities are tailored to changing combat situations. Maintenance, supply, and other support elements are coordinated and positioned to be instantly responsive to the requirements of the battalion.

ORGANIZATIONS AND FUNCTIONS

Patriot battalions should emphasize coordination with the ADA brigade, corps,

and EAC units to capture all available resources.

ADA BRIGADE

Discussion about the ADA brigade is included to facilitate adequate understanding of the support operations conducted at corps and EAC level. The ADA brigade, whether assigned at corps or EAC, concentrates on centralized logistics staff planning to interface with corps and EAC Materiel Management Centers (MMCs).

At the corps level, the ADA brigade receives support from the corps support command's (COSCOM) corps support battalion (CSB) assigned to the corps support group (CSG). In some cases, support may come from the division support command's (DISCOM) forward support battalions (FSBs) and main support battalion (MSB). To draw logistics support from corps support elements through MMCs, the ADA brigade has to centralize its requirements. The central logistics staff planning and visibility function can be accomplished by an expanded brigade S4 that has responsibility for planning supply, maintenance, transportation, services, and support operations functions. The expanded brigade S4 section interfaces with the corps MMCs to secure support.

At EAC level, the ADA brigade receives logistics support from the appropriate functional battalion assigned to the TAACOM's area support groups (ASGs). In some cases, EAC ADA brigade elements operating within corps forward areas receive their support as described above. Because of the large area of operations for an EAC ADA brigade and the wide dispersion of the support elements, the EAC brigade must be aggressive in task-organizing available logistics personnel and assets to provide continuous support.

PATRIOT BATTALION

The Patriot battalion commander provides logistics support for his organic elements and for any attached elements. Logistics support

received through the ADA battalion encompasses those support activities required to sustain campaigns and major operations.

Organization

Patriot battalion support is provided by the organic supply and maintenance support element of the battalion. It normally deals with Classes I, II, III (package), IV, V, VII, and IX. The batteries coordinate through the battalion to draw or receive support. Higher echelons provide combat elements with food, fuel, ammunition (both conventional and missile), some maintenance, and medical support when required. The battalion S4 coordinates logistics support for assigned or attached Patriot batteries.

Mission

The battalion S4 must thoroughly understand the battalion mission. To provide positive and responsive support to each element of the supported force, he must determine the needs of each supported element, when and where it will be done, and how it will be accomplished. The type, quantity, and priority of required logistics support must be understood and defined.

Materiel Supported

Anticipation and planning are very important for supply Classes II, III, IV, V, VII, and IX and materiel maintenance because all these items and actions are sensitive to variations in weather, terrain, and the tactical situation. Class III and Class V supply are both particularly sensitive to variations in intensity of combat. Before any type of operation, direct coordination between the S3 and the S4 in both of these areas is required to determine support requirements. Materiel densities in each support area within the battalion must be

established so risks may be assessed, proper operational decisions made, and adequate supply and maintenance resources allocated to meet support requirements. For Class VIII, medical materiel requirements are based upon medical materiel densities and the level of patient support activity. Water supply is affected by the environment.

Logistics Assets and Functions

The battalion executive officer (XO) is the manager of all administrative and logistical functions within the battalion. In addition, he is normally responsible for coordinating maintenance and reconstitution efforts. As such, he should organize and take advantage of all assets available. Some materiel readiness functions the XO must coordinate throughout the battalion are—

- Apprising the commander of materiel readiness.
- Cross-leveling within the battalion for required repair parts.
- Providing assistance to subordinate units on materiel readiness problems.
- Providing liaison with higher headquarters and outside agencies regarding materiel readiness.

The XO and the logistics personnel are normally located with the battalion trains during combat operations.

Personnel officer (S1). The S1 prepares the personnel estimate, and assists the S4 with preparation of the support annex to the OPORD. The focus during planning must be on maintenance of unit strength and soldier readiness. The S1 is the primary administrative officer. He is responsible for administrative functions within the battalion such as strength accounting, forecasting personnel requirements, replacement operations, and casualty operations. The S1, as morale officer, is also responsible for mail. He is normally located wherever

the battalion TOC is during combat operations. The S1 also has primary staff responsibility for enemy prisoner of war (EPW) operations and medical planning. He coordinates with the S2 for interrogation of prisoners and with the S4 for processing captured equipment and for transportation requirements. The S1 coordinates with the battalion surgeon to ensure that patient treatment and evacuation are planned and coordinated throughout the battalion.

S1 section. The S1 section provides personnel, legal, finance actions, and other general administrative services for the battalion. If the battalion chooses to echelon its trains into combat trains and field trains, the S1 section has personnel at both locations. The S1 and his staff, in the combat trains command post (CP), primarily perform the critical tasks of strength accounting and forecasting, as well as CP functions, S1 personnel in the field trains perform the critical task of casualty reporting, as well as replacement operations, administrative services, personnel actions, legal services, and finance services.

The S1 plans and coordinates EPW operations, collection points, and evacuation procedures. EPWs are evacuated from the battalion area as rapidly as possible. The capturing battery is responsible for guarding EPWs until relieved by proper authority, recovering weapons and equipment, removing documents with intelligence value, and reporting to the field and combat trains CPs. EPWs may be evacuated to the vicinity of the combat trains for processing and initial interrogation.

Battalion surgeon. The battalion surgeon operates the battalion aid station. He also coordinates the operations, administration, and logistics of the medical section. This includes coordinating patient evacuation to the supporting medical company and providing support to batteries.

Medical section. The medical section sorts, treats, and evacuates casualties or returns them

to duty. It carries a basic load of supplies for medical section operations. It is also responsible for maintaining and evacuating battalion medical equipment.

Chaplain. The chaplain supports the S1 as the morale officer. He conducts religious services, personal and religious counseling, and pastoral care.

S4. The S4 is the logistics officer for the battalion, and is responsible for supply, maintenance, and transportation of unit personnel and equipment. He forecasts logistical requirements and supports requests from subordinate units. During combat, the S4 concentrates on seven classes of supply: Classes I, II, III, IV, V, VII, and IX. The S4 and headquarters and headquarters battery (HHB) commander coordinate the requisition, receipt, preparation, and delivery of Classes I, III, and V. The S4 is supported by the battalion maintenance officer (BMO), the food service noncommissioned officer (NCO), and the S4 section (which includes a missile reload section).

S4 section. The S4 section is responsible for supply, transportation, and field service functions. The section coordinates requisition and distribution of supplies to battery supply sections and turns in captured supplies and equipment as directed. If the battalion chooses to subdivide its trains into combat trains and field trains, the S4 section has personnel at both locations. They are cross-trained with personnel from the S1 section in critical tasks to permit continuous operations. The supply section coordinates the requisition, receipt, and delivery of Classes II, IV, VII, and IX.

Battalion maintenance officer. The BMO monitors and supervises motor maintenance activities within the battalion. He advises the battalion XO on vehicle repair, conventional maintenance, and recovery operations. He monitors the status of the

battery motor pools and coordinates with the combat support company (CSC) on priority of repair.

Electronic missile maintenance officer. The EMMO evaluates, supervises, and monitors Patriot missile maintenance operations throughout the battalion. He advises the battalion XO and the S3 on Patriot unit system outages, system capabilities, and status. He also assists battery warrant officers with maintenance programs and coordinates with the direct support (DS) unit on repair priority.

Task Force Operations

Task force (TF) operations with Hawk add additional planning and sustaining operations. When a Hawk unit joins the battalion and a TF is created, the attachment should bring an appropriate "slice" of CSS assets from its parent unit. Likewise, when a Patriot "slice" joins a Hawk-heavy TF, these assets are integrated by the TF S4. The attached unit leader must coordinate with the TF S1 and furnish a copy of his unit battle roster. Thereafter, the attached unit submits reports and requests resupply according to the TF SOP. Everyone involved must understand his responsibilities and those of the CSS organizations.

PATRIOT BATTERY

The fire unit is the lowest tactical organizational unit with personnel designated by the modified table of organization and equipment (MTOE) to perform logistics functions. Battery elements perform unit-level maintenance and supervise unit supply operations. It is at the battery level that supply requests, personnel status reports, and other requirements for logistics support originate.

Organization

The first sergeant controls the unit trains which include the mess team, supply section, POL handlers, mechanics, and medics.

Battery Elements

The battery commander has overall responsibility for logistics in the battery. During combat operations, the battery XO, first sergeant, and battery warrant officer assist in the supervision and execution of logistics operations.

Battery executive officer. The battery XO is the logistics coordinator. During preparation for the operation, he coordinates closely with the first sergeant, the conventional motor maintenance officer, and the Patriot missile system technician to determine what is required and makes sure arrangements have been made to support the tactical plan. Besides his tactical requirements, he manages and monitors the battery's logistics operations. The XO also receives periodic maintenance updates from platoon leaders, platoon sergeants, the first sergeant, and warrant officers.

Motor sergeant. The motor sergeant supports the battery maintenance officer and ensures all maintenance procedures are properly followed. Other section supervisors will also ensure that proper organizational maintenance is performed on equipment assigned to their respective sections. The motor sergeant organizes and supervises motor maintenance and advises the XO and first sergeant on vehicle recovery, repair, and destruction. He directs the motor maintenance and ensures requests for repair parts are prepared and forwarded to the battalion S4. This NCO distributes repair parts when they are received and supervises exchange and cannibalization when authority is delegated to him. He coordinates with platoon sergeants for maintenance status of the platoons.

Patriot missile systems technicians. The Patriot missile systems technicians are extremely important logistics members of the Patriot battery. They are the Patriot system experts. They are responsible for maintaining all Patriot equipment assigned to the battery according to the maintenance SOP. These officers, using the unit-level logistics system (ULLS), control the Patriot prescribed load list (PLL), and the usage of Patriot peculiar repair parts. They advise the platoon leaders and battery commander on Patriot system capabilities, limitations, and equipment status. They coordinate among battery officers to ensure Patriot peculiar parts and supplies are available for maintaining a mission-capable posture. They direct the actions of Patriot system maintenance personnel and ensure Patriot equipment outages, work orders, and requisitions for repair are initiated and recorded. Patriot warrant officers ensure Patriot equipment status reports are forwarded to the battalion per SOP. The systems maintenance officer is normally located in the battery maintenance group during combat operations, but may be located with the battery CP as necessary for coordination of missile maintenance and logistics actions.

First sergeant. The first sergeant is the battery's primary CSS operator. He executes the battery logistical plan, relying heavily on the battery and battalion SOP. The first sergeant directly supervises and controls the battery trains. He receives CSS reports from the platoon sergeants, provides information to the XO, helps the XO complete CSS preparations, and plans and conducts CSS operations. He also receives, consolidates, and forwards all administrative, personnel, and casualty reports to the battalion trains. He directs the medical evacuation team forward when the situation requires. He orients new personnel to the battery and assigns replacements to the platoons. The

first sergeant supervises the evacuation of casualties, EPWs, and damaged equipment. Additionally, he maintains the battle roster for the battery.

Motor pool personnel. Motor pool personnel, using the ULLS, maintain the unit's conventional PLL. Standardized combat PLL items set forth in the mandatory parts list for the unit's TOE must be stocked in the PLL. Other items may be stocked, based upon demands and availability of funds. Arms room equipment, NBC equipment, and dining facility equipment must be considered when designing a unit's PLL. AR 710-2, DA Pamphlet 710-2-1, and automated system user manuals provide guidance for maintaining a PLL.

Supply sergeant. The supply sergeant is the battery's representative to the battalion CSS elements. He submits requests for issue and turn-in of Class II, IV, VII, VIII (first aid and combat lifesaver supplies only), and IX items. The supply sergeant coordinates with the battalion S4 for Class I, III, and V supplies. He maintains individual supply and clothing records and picks up personnel replacements at the battalion and or task force trains and prepares them for the first sergeant. He also receives and evacuates personnel killed in action (KIA) to the mortuary affairs collection point in the support area.

Supply room personnel. Supply room personnel maintain the battery commander's hand receipts, as well as run other supply room functions. It is the supply sergeant's job to maintain the subhand receipts, as well as the component listings. The supply room is responsible for ordering supplies for the unit.

Supervisors. Supervisors assigned to the various sections in the unit are responsible to ensure that all supply procedures are properly followed. It is the section sergeant's responsibility to ensure that all of the equipment under his control is properly accounted for and

subhand receipted down to the lowest level possible.

COMBAT SUPPORT COMPANY (DS), PATRIOT

This company provides maintenance support to Patriot batteries through the battalion. It repairs automotive, communications, communications security (COMSEC), construction, power generation, small arms, turbine engine, quartermaster, chemical, and utilities equipment. It performs metalworking functions and repairs special electronics devices and tactical microwave systems. The company also conducts 120-day and longer interval preventive maintenance checks and services. For Patriot nonsystems equipment, the DS company provides the following support to the Patriot battalion and battery.

Technical Supply

The technical supply section manages the flow of repair parts. This section stocks and dispenses repair parts used by the supported units.

Patriot DS and GS Augmentation

The augmentation team provides DS and general support (GS) maintenance for the Patriot missile system at EAC or corps. This support includes limited base shop and two maintenance support teams (MSTs) for Patriot peculiar equipment, limited Class IX (base shop and MST) support, and Stinger air bottle recharge.

Conventional Equipment Maintenance

The conventional maintenance platoon provides automotive, communications, COMSEC, power, and air-conditioning repairs for the Patriot battalion.

PLANNING

Logistics planning ensures support during all phases of an operation. The plan is developed concurrently with the tactical plan. Supporting plans are as detailed as planning time permits. Using SOPs and planning for contingencies will greatly assist the logistics staff officers in the planning efforts. Task force orders only address deviations from the routine planning priorities established in the SOP.

PRINCIPLES

Successful operations depend on three basic principles. These principles must direct the logistics effort as follows:

- Logistics functions are anticipatory in nature and are performed as far forward as the tactical situation permits. Support must be continuous, using immediately available assets. Ammunition, fuels, parts, end items, maintenance personnel, and replacements are “pushed” forward to the combat trains, unit maintenance collection point (if established), and logistical release points (LRPs).
- Logistics planning is a continuous function. Coordination among tactical planners and logistics planners is essential and addresses all factors that can greatly affect the tactical mission.
- Staff officers and commanders must act rather than react to support requirements. Personal involvement, remaining abreast of the tactical situation, and on-the-scene

appraisal of the situation are critical to mission accomplishment.

SUPPORT OF COMBAT OPERATIONS

Logistical planning begins when the unit starts to formulate a tactical plan. The XO and the S4 must participate in developing the logistics annex to the tactical plan. The planning process begins when the battalion commander provides mission guidance to the staff. The XO and other staff follow the planning process outlined in FM 101-5. The logistics estimate is an analysis of logistics factors affecting mission accomplishment. Logistics planners use these estimates to recommend COAs and to develop plans to support selected concepts of operation. The key concerns of ADA battalion logistics planners are the status of supply Classes III, V, and IX, and the operational status of ADA equipment, generators, and associated vehicles. To ensure effective support, logistics planners must understand the commander’s tactical plans and intent. They must know—

- What each of the supported elements will be doing.
 - When they will do it.
 - How they will do it.
- After analyzing the concept of operations, logistics planners must be able to accurately predict support requirements. They determine—
- What type of support is required.
 - What quantities of support are required.
 - The priority of support, by type and unit.

OPERATIONS

Patriot battalion and battery commanders can ensure flexibility by tailoring organizations and methods. They should not allow themselves or their organizations to be bound by traditional support methods. Logistics planners, for their part, must accept deviation

from plans as routine. They must use initiative to carry out their responsibilities, know the CSS requirements of their forces and the details of operational plans, and devise innovative ways to support the plan and reduce the risks.

The battalion's combat mission must remain the first consideration in the task organization. Resources and priorities must be adapted to changing combat situations. Assets must be flexible enough to support from any base arrangement and still be able to survive and accomplish their mission. Maintenance, supply, and other support elements must be instantly responsive to the requirements of the unit. All of this means continual and direct coordination between operations planners (battalion S3).

In coordination with the battalion S3, the S4 must establish priorities for support. Ammunition and bulk fuel resupply, DS maintenance, personnel replacement, and medical evacuation may all have high priority, depending on the tactical plan. Effective communications must be maintained between the Patriot battalion staff and the staff of the ADA brigade to determine the support requirements of the battalion and to coordinate support activities.

Close coordination is also necessary to ensure that units with the highest tactical priority receive their required support first. Effective communications and coordination enable support elements to emphasize the flow of supplies rather than the buildup of stocks. It may be necessary to stock critical supplies near points of anticipated consumption to permit continued operations in the event of disruptions in the supply system. However, such actions must not impede battery mobility. It may be necessary for the support elements to shuttle many of the required supplies. Constant and complete coordination is also necessary to ensure effective and integrated transportation support inconstantly changing circumstances.

POSITIONING CONSIDERATIONS

Built-up areas are good locations for trains. They provide cover and concealment for

vehicles and shelter that enhance light discipline during maintenance. When built-up areas are used, trains elements should occupy buildings near the edge of the area to preclude being trapped in the center.

The following factors govern the positioning of the battalion trains:

- Room for dispersion and cover and concealment from both air and ground observation.
- Ground that supports vehicle traffic.
- A nearby helicopter landing site.
- Routes to LRPs or to battery positions.
- Unrestricted movement in and out of the area.

The positioning of battalion trains is dependent on three factors: the amount of available cover and concealment, intensity of enemy activity in the area, and whether the type of operation underway is offensive or defensive.

TRAINS SECURITY

Elements behind the FLOT form base clusters and must be prepared to defend themselves against guerrillas, special operations type forces, and forces that have broken through or bypassed the defense. Responsibility for trains security should be delineated in the unit SOP. In all trains areas, a perimeter defense is normally planned. Elements in the trains are assigned a specific sector to defend. Mutually supporting positions that dominate likely AAs are selected for vehicles armed with heavy machine guns. Reaction forces and observation posts (OPs) are established, based on the unit SOP. To enhance security, an alarm or warning system is arranged. Sector sketches, fire plans, and obstacle plans should be prepared. Rehearsals are conducted to ensure that all personnel know the part they play in the defensive scheme. The OIC establishes a shift schedule for operations and security on a 24-hour basis.

COMMAND AND CONTROL

Logistics C² in the Patriot battalion is defined as the system used to control and direct activities to support accomplishment of the mission. The essential elements are an established hierarchy of control centers, continuous communications between those control centers and a responsive logistics control element (S4, battalion XO, and battery executive officer), and supervision of the execution of the logistics support plan.

COMMUNICATIONS

Patriot battalion logistics support has the internal UHF network as its primary communications (see Figure 6-1). FM/AM system net serves as the alternate communications means. During movements, it serves as the primary means of communications. For lengthy reports, use messenger, wire, or mobile subscriber equipment (MSE) communications.

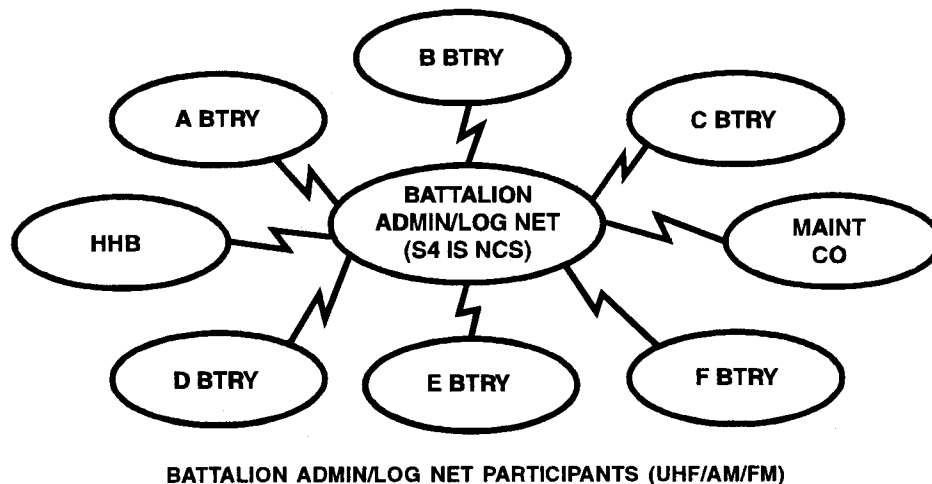

Figure 6-1. ADA logistics net.

SUPPLY

EAC and corps customers request supplies from the supply point assigned to support them. Classes II, III, IV, and VII, and DS water support are provided to ADA units by the supply company (DS) respectively assigned or attached to the CSG or ASG battalions in the COSCOM and TAACOM to provide area support. ADA units submit requests for these classes of supply to the designated supply company's direct support unit (DSU), which either fills the request or passes the requisition to the corps materiel management center (CMMC) or the TAACOM MMC for action. Most

requirements for Class VII items are submitted by units to the proper S4 property book officer and or section, which then submits requisitions to the DSU. Class V and IX support is provided by the designated COSCOM and TAACOM operated ammunition supply point (ASP), and the nondivisional maintenance company, respectively. All DSUs provide supply point distribution on an area or task basis. Clothing exchange and bath (CEB) and mortuary affairs services are provided on an area basis by the field service company and mortuary affairs elements respectively assigned or attached to the CSG or ASG.

The corps or TAACOM MMC may direct issue from another DSU to the customer, or direct issue from corps and or theater GS stocks to the servicing DSU, which then issues to the customer. While issue from the supply point is considered the normal method of distribution, the MMC can order direct unit distribution. This would consist of delivery of the requisitioned items from the designated DS or GS supply source directly to the supported ADA unit customer, using corps or theater army transportation assets.

The battalion always maintains some combat-essential supplies and repair parts. These are called combat loads, basic loads, and PLLs. The minimum stockage level is normally directed by brigade or higher. The purpose of these loads is to enable a unit to sustain itself in combat for a limited period, should there be an interruption in the resupply system. This period normally is 15 days for general supplies and repair parts, and 3 to 5 days for Classes I, III, and V.

CATEGORIES OF SUPPLIES

There are three categories of supplies, with regard to how supplies are requested and issued. These are discussed in the following paragraphs.

Scheduled Supplies

Scheduled supplies are those for which requirements can be reasonably predicted or have a recurring demand. Normally, a scheduled supply does not require submission of requisitions by users for its replenishment. Requirements are based, for the most part, on troop strength, equipment density, forecasts, and or daily usage factors. Scheduled supplies are normally shipped to users on the basis of preplanned distribution schemes.

- Classes I, III (bulk), V, and VI are normally treated as scheduled supplies.
- Class II and VI (general supplies and equipment, and personal demand items)

requirements are based on troop strength.

- Class III (bulk POL) requirements are based on long-range forecasts, equipment densities, and historic usage factors (experience).
- Class V (ammunition) requirements are based on densities of weapons and nature of mission(s).

Demanded Supplies

Demanded supplies are those for which a requisition must be submitted. This is for expendable items such as nuts and bolts, tools, or items that have a recurring demand. Items in supply Classes I, III (packaged), VI, VII, and IX are considered demanded supplies.

Regulated Supplies

Regulated supplies can be scheduled or demanded, but the commander must closely control these supplies because of scarcity, high cost, or mission need. Any item or group of items can be designated as regulated. Normally, some items in supply Classes II, III bulk, IV, V, and VII are regulated. If an item is regulated, the commander who so designates it must approve its release prior to issue. Items designated as command regulated are identified in operation plans (OPLANs) and OPORDs for operations that occur during the time in which the items are regulated.

DISTRIBUTION METHODS

The battalion uses two distribution methods to replenish its stocks: supply point and unit. Established requisition channels are used, regardless of the issue method chosen by higher headquarters. The S4 section is organized to process supply requests and to receive, issue, and temporarily store supplies. Distribution priorities for items in short supply are determined by the commander, based on

recommendations by the S4 and the operational requirements of the battalion.

Supply Point Distribution

The battalion, using organic transportation, goes to the supply point to pick up supplies. This is the normal method used.

Unit Distribution

Supplies are delivered to the battalion by transportation assets other than its own. The battalion uses unit distribution to resupply its subordinate elements. When feasible, supplies are shipped directly from the issuing agency as far forward as possible, provided that the receiving unit has the material-handling equipment necessary to handle the shipping containers. This means that some supplies may be issued directly to the battalion from COSCOM or even theater army level, especially Classes III and VII. This issue usually occurs no farther forward than the field trains.

CLASSES OF SUPPLY

Supplies are grouped into 10 classes (Classes I through X) and miscellaneous supplies.

Class I—Subsistence Items

In the initial states of combat, rations are pushed through the system based on strength reports. Water is not a Class I supply item, but is normally delivered with Class I. Water supply points are established as far forward as possible. Water for the battalion and or battery is picked up in water trailers from an area water point which, whenever possible, is collocated with the Class I supply point.

Class II-General Supplies and Equipment

Battalion and battery requirements for Class II supplies (other than principal items) are

submitted to the supporting COSCOM or TAACOM supply company (DS). The DSU then fills the requirement from its supply point inventory, or passes the requisitions to the CMMC or the TAACOM MMC for action.

Class III—Petroleum, Oils, and Lubricants

POL consists of petroleum fuels, hydraulic and insulating oils, chemical products, anti-freeze compounds, compressed gases, and coal. Unit requirements for Class III packaged materials are submitted to the supporting COSCOM or TAACOM supply command (DS). The DSU fills requisitions from its supply point inventory or passes the requisition to the CMMC or the TAACOM MMC for action. A dedicated supply system manages, transports in special containers, and issues the supply of bulk petroleum products. POL is obtained by the battalion or battery using organic bulk POL assets from the designated Class III supply point established by the supply company (DS). A formal request is not needed to obtain bulk fuel at a supply point. Requests from batteries to the battalion are not required for bulk POL resupply. POL carriers move forward with each logistics package (LOGPAC) to the batteries as needed.

Class IV—Engineer Supplies

This class includes construction and barrier materials: lumber, sandbags, and barbed wire. Class IV supplies are requisitioned in the same manner as Class II.

Class V—Ammunition

Timely resupply of ammunition is critical. To determine the requirements for a specific operation or time period, Patriot units develop a required supply rate (RSR) for each type of ammunition. Expressed as rounds per weapon per day, the RSR may derive from experience

or from reference manuals. The operations officer (S3) prepares the RSR for the commander during the planning stages of the operation. Requests are consolidated at each level until they reach the highest Army headquarters in the theater (corps and EAC). At that level, the G3, G4, and commander review the requirements and availability of ammunition. Based on this review, the force commander establishes a controlled supply rate (CSR), the actual resupply rate. The CSR is expressed as rounds per weapon per day by ammunition item. The OPLAN or OPORD will normally identify those ammunition items for which the CSR is less than the RSR. After consulting with their operations and logistics staff officers, commanders will normally establish priorities for the allocation of ammunition.

Unit basic load. The unit basic load is the quantity of conventional ammunition authorized and required by a unit to sustain itself until normal resupply can be effected. The unit basic load must be capable of being carried in one lift by the unit's soldiers and organic vehicles. SOPs will prescribe distribution of the basic load. In a mature theater, units will have their basic load. Units deploying to a theater normally carry their basic load with them. However, a unit arriving in theater without a basic load will receive it at a designated ammunition supply location. A unit's basic load is designed to meet its anticipated initial combat needs and is influenced by the following factors:

- Mission.
- Types and numbers of weapon systems.
- Transport capability.
- Time required to conduct resupply.

Missile support concept. For requisition of Patriot missiles, the battalion S4 generates requests based on missile expenditure reports submitted to the S3. The S4 coordinates these requests with the ADA brigade S3 before submitting his DA Form 581 to the appropriate ammunition transfer point (ATP), ASP, corps

storage area (CSA), or theater storage area (TSA). The requests are prioritized at brigade by the S3 in coordination with the brigade S4 to ensure that there is no impact on the brigade's mission. The battalion is then notified of what has been approved for annotation on the DA Form 581.

Patriot missiles are classified as conventional ammunition, and as such arrive at the theater of operation from the continental United States (CONUS) using the same channels as conventional ammunition (see Figure 6-2). From port areas, missiles move directly to the TSA. Delivery of high-cost, low-density missiles such as Patriot can be made by theater transportation assets directly to the Patriot battalion from the theater storage area (throughput). The battalion accepts delivery in or near the battalion area. In emergency situations, Army aviation assets may be used to airlift Patriot missiles directly from the CSA to the battalion or fire unit.

Missile resupply operations. Depending on the tempo of combat operations, the number of missiles available in the theater, and the availability of transport, resupply maybe either centralized (push) at battalion or decentralized (pull) at battery.

Key considerations have to be taken into account by commanders and staff officers when deciding how to structure missile resupply operations. First, the guided missile transporter (GMT) is the only organic means the battalion has for loading missiles onto the launcher. If GMTs are used for transporting missiles, they cannot, at the same time, be used for reloading launchers. Second, the launcher that has fired its missiles is of no use to the battery. Third, Patriot missiles delivered by theater transportation assets directly to the Patriot battalion area may be delivered in military vans (MILVANS). Upon receipt of the MILVANS, the battalion S4 is responsible for the unloading of the missile canisters (see the MILVAN Unload Checklist in Appendix A).

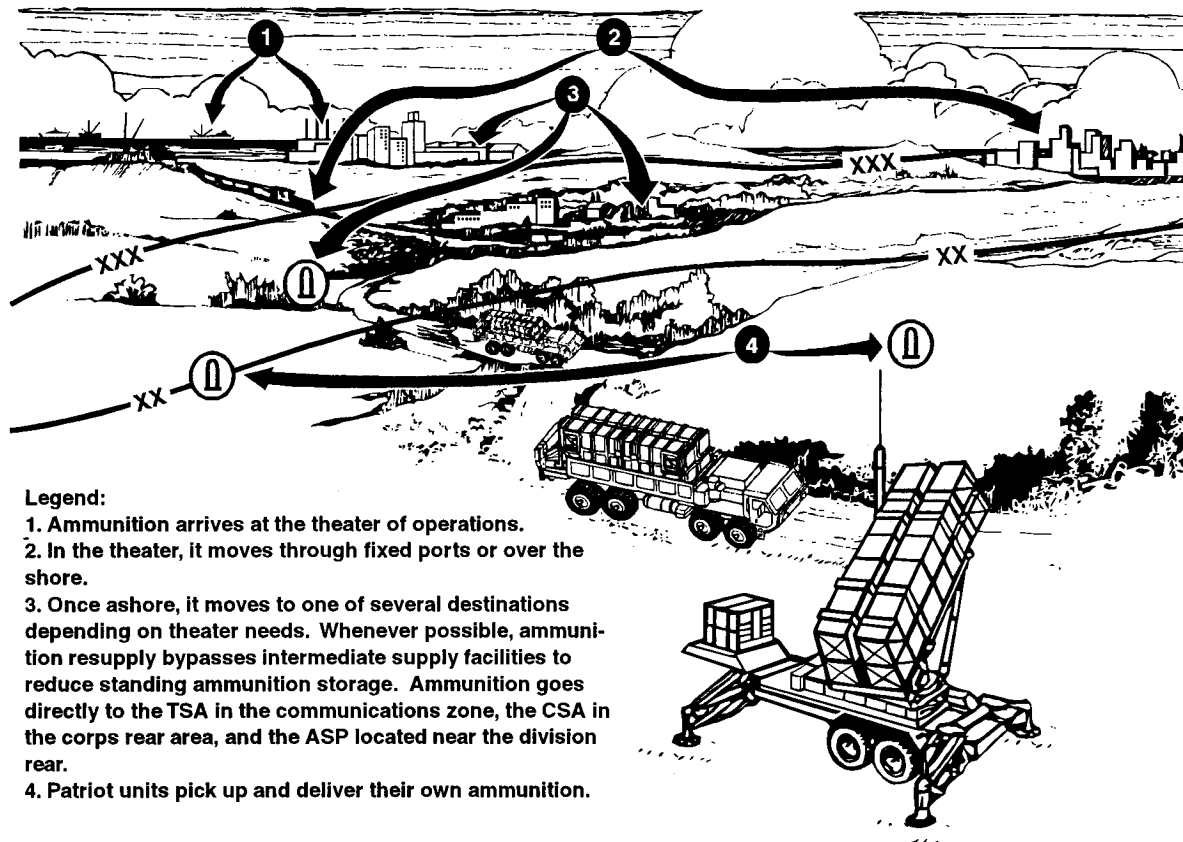

Figure 6-2. Ammunition supply procedures.

The checklist for the loading of the missile canisters into MILVANS is also in Appendix A. The S4 must use two 10-ton all-terrain forklifts for removing missiles from MILVANS and loading GMTs.

Under centralized missile resupply (see Figure 6-3 on page 6-14), theater or corps transportation assets, or host nation transportation support, move missiles forward to ATPs designated by the brigade. This point should be centrally located in the AO. Current Patriot TOEs establish a missile resupply section under the supervision of the battalion S4. This section includes the personnel and equipment necessary to operate six missile resupply teams.

The missile resupply section operates the centralized facility that provides the batteries with ready-to-fire missiles. The battery sends the launcher to the missile resupply point. When the launcher has been loaded, the reload crew chief notifies the battalion S3, who decides where that launcher should go. The centralized concept assumes that launchers may not go back to their own battery, but will be sent where the tactical situation dictates they are most needed. The ability to communicate between the battalion TOC and the missile resupply point is critical. Launcher section chiefs must be able to navigate well for this concept to function.

effectively. The decision to provide the missiles to a battery is based on the tactical situation and mission requirements.

Decentralized missile reload has two possible variations. The first is battalion control, where the battalion retains control over all reload assets. This requires the battalion missile resupply section to pickup, deliver, and load missiles at the batteries designated by the S3. The second is battery control, where the battalion attaches GMTs to the batteries for them to pickup their own missiles. As shown in Figure 6-4, the battery uses an attached battalion missile resupply vehicle to pickup missiles from the closest CSA/ASP or division ATP. The battery then transports the missile to its location where the missiles are either stored or placed on launchers. Both variations of this concept should be used when the tempo of combat operations in corps areas is slower, or in theater rear areas where batteries may be located close to ASPs.

Class VI—Personal Demand and Morale Items

Class VI includes candy, cigarettes, soap, and cameras (nonmilitary sales items), and sundry packs. Requests for Class VI support are submitted by the S1 through supply channels when an Army exchange is not available. Resupply flow is the same as for Class I resupply.

Class VII—Major End Items

Launchers, generators, vehicles, and other major end items are Class VII supplies. Major end items are issued in combat based on battle loss reports. Large items may be delivered by COSCOM directly to the battalion trains. Smaller items are picked up by the S4 at the

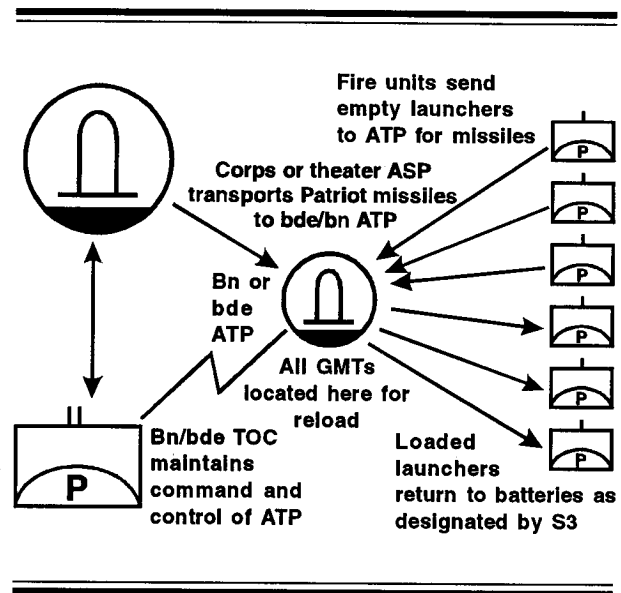

Figure 6-3. Centralized Patriot missile resupply.

distribution point in the theater or corps support area. The battalion XO sends ready-to-fight weapon systems forward with the LOGPAC.

Class VIII—Medical Supply

The medical platoon maintains a 2-day (48-hour) stockage of medical supplies. Normal medical resupply of the platoon is performed through backhaul. Medical resupply may also be by preconfigured Class VIII packages (push packages) throughput from the forward medical logistics (MEDLOG) battalion located in the corps support area.

In a tactical environment, the emergency medical resupply (ambulance backhaul) system is used. In this environment, medical supplies are obtained informally and as rapidly as possible, using any available medical transportation assets. The medical platoon submits supply requests to the supporting medical company. Class VIII resupply of combat medics is performed by ambulances of the medical platoon.

Class IX—Repair Parts and Components

Class IX includes kits, assemblies, and subassemblies-repairable or unrepairable—that are required for maintenance support of all equipment. ADA brigade, battalion, or battery unit maintenance personnel submit Class IX requests and turn-ins to their supporting DSUs. Corps and theater army ADA units receive Class IX support from the nondivisional maintenance company (DS) assigned to either the COSCOM or the TMCOM. The corps missile support company and the missile support company (EAC), respectively assigned to the COSCOM or TAACOM, provide missile Class IX and repairable exchange (RX) supply support to customer units. The designated nondivisional maintenance company (DS) maintains the ASL for corps and theater army units. ASL stockage is determined by the corps movement control center (CMCC) or the TAACOM MMC.

Patriot DS maintenance. The Patriot maintenance company (DS) is authorized a shop stock of DS replaceable items, while organic battery maintenance elements are authorized a PLL.

Requisitioning. Batteries obtain Class IX supply support for their PLLs. Requirements for parts not supported by the PLLs are submitted on DA Form 2765 or requested by the unit-level logistics system.

RX for selected repairable items (to include components, racks, and major assemblies) is accomplished by exchanging the unserviceable item for a serviceable item. Unserviceable items must have DA Form 5988-E attached so the maintenance support activity can do a quality assurance (QA) inspection. RX items are normally limited to those authorized for replacement by supported units.

Unit PLLs submit requests to their supply element. This allows validation of mission

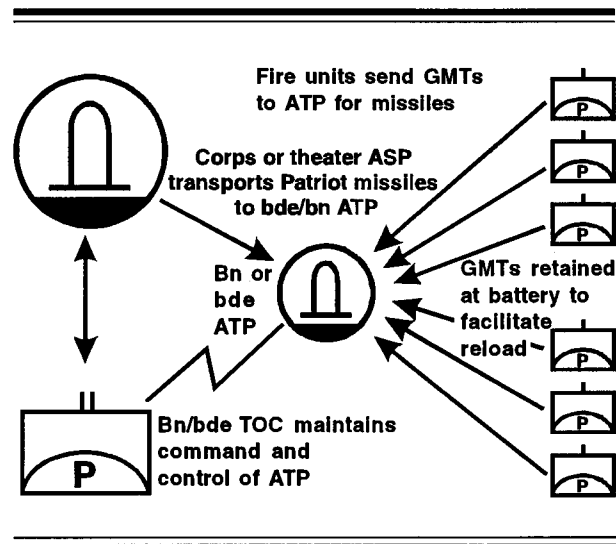

Figure 6-4. Decentralized Patriot missile resupply.

critical repair parts at the supporting supply element. From there, requests are delivered or transmitted to the nondivisional maintenance company ASL and from thence either the CMCC or the TAACOM MMC.

The CMCC or TAACOM MMC provides document control and supply management for the items requested. Supply management is accomplished by a combination of manual and machine methods. DSU procedures provide increased management control. The materiel officer (MATO) can introduce criteria and parameters to be programmed so machine methods may be used to control available assets, or manual intervention can be used when human judgment is required.

Receipt, storage, and issue. Under direct supply support (DSS), Class IX items arriving in the battalion are received by the battalion maintenance company's technical supply operating elements. Nonstocked logistics (NSL) items are forwarded directly to the units that ordered them. Turn-ins are handled in the same manner as receipts and are also reported.

Class X—Nonmilitary Items

Material to support nonmilitary programs such as agriculture and economic development (not included in Classes I through IX) is Class X. These items are requested and

obtained by the S4 based on civil-military requirements. Specific instructions for request and issue of Class X supplies are provided by division or higher.

MAINTENANCE

Maintenance is sustaining materiel and equipment in an operational status, restoring it to serviceable condition, and upgrading functional abilities through modification. These functions are performed at four levels—organizational, DS, GS, and depot. Successful maintenance at these levels is the key to a unit's ability to shoot, move, and communicate. Therefore, maintenance must be a top priority at all levels.

providing area support and backup support to other maintenance units during surge periods or to provide reconstitution support. In cases such as these, mobile augmentation (tailored support) teams may be assigned.

OPERATOR MAINTENANCE

A key aspect of maintenance is the ability to repair equipment quickly and as close as possible to the point of equipment failure or damage. The operator is the first link in the chain of maintenance followed by the organizational mechanics of the using and or owning unit. These soldiers must use their fullest capabilities to reduce downtime and to identify organizational deficiencies. If a deficiency is beyond organizational-level capability, then DS- or GS-level maintenance is requested.

DS maintenance units use maintenance support teams (MSTs) or contact teams to provide close-in support and on-site repair (fix forward) of critical systems. DS maintenance units will then establish base operations and MCPs for repair of equipment which cannot be repaired on site. Their capabilities and capacities are tailored to the types and densities of equipment and units for which they provide support. The MSTs are deployed from the maintenance units to supported unit MCPs or directly to downed equipment evacuated to a safe position, depending upon the situation.

DS/GS MAINTENANCE

The function of direct support maintenance is to repair end items and return them to the user and or owner unit. It must be mobile and focus support as far forward as possible.

The MST's maintenance capability is constrained by time, environment, and total maintenance burden. At supported unit MCPs, these teams must assess the total maintenance burden with the objective of returning the maximum number of weapon systems to combat in the minimum amount of time. Thus, full use of controlled substitution and cannibalization is made. The tactical situation is the overriding factor. By using diagnostic test sets, the MSTs can concentrate on component or assembly replacement. The unserviceable components are sent to the DS maintenance unit.

Direct support (conventional) maintenance units perform maintenance on an area or task basis in the theater of operations. Each DS maintenance unit establishes and operates maintenance collection points (MCPs) and base maintenance areas for support of all customer units. Certain units may have the job of

For DS maintenance units, emphasis is placed on repair of end items, and some repair of components and modules. The extent of maintenance performed is restricted by time available for repair, availability of repair parts, resupply, work load, and priorities. The DS

maintenance is performed at corps level by the nondivisional maintenance company (DS) assigned or attached to the CSB/CSG in the COSCOM. DS maintenance is performed at EAC by the nondivisional maintenance company (DS) assigned to the maintenance battalion of the ASG or TAACOM. These COSCOM or TAACOM missile support DS maintenance units provide DS or backup DS to the Patriot battalion or battery, and have a Class IX repair parts direct support supply mission. These units maintain ASLs and RX functions which reflect the items in demand-supported stocks. Parts and RX items are also provided to the MSTs in the repair of end items or components. If the maintenance unit is unable to repair Patriot end items or components at its level, the end item or component is sent to depot. GS maintenance is primarily limited to repair and return to the supply system. GS maintenance is provided at the COSCOM or theater level.

DEPOT-LEVEL MAINTENANCE

Depot-level maintenance is performed in fixed facilities and is production-oriented. The mission is primarily rebuilding or refurbishing end items and some components. Repair time guidelines are not established.

RECOVERY AND EVACUATION

Each unit is responsible for recovering its own damaged equipment. Wreckers and other recovery vehicles should be used to move irreparable equipment to collection points along designated routes. Immovable items remain in place until supporting maintenance units can recover them. Unserviceable materiel should be recovered to the nearest collecting point or main supply route (MSR) as appropriate, and should be protected from pilferage and deterioration. Maximum use is made of on-site repairs

before unserviceable equipment is recovered. Using units should attempt recovery within their capability and request assistance from the supporting element, when necessary.

Evacuation begins when recovery operations end. It is a coordinated effort between maintenance, supply, and transportation elements. It includes end items and unserviceable assemblies and components. Evacuation of unserviceable materiel starts at the DS maintenance collection point or designated MSR.

Commanders must establish priorities for recovery and evacuation of materiel under their control. Priorities established should offer the greatest potential for the early return of equipment to service.

OPERATIONAL READINESS FLOAT

An operational readiness float (ORF) is a major end item to provide replacement for an unserviceable item of equipment when repairs cannot be accomplished within a command set time.

Selected ORF end items are maintained by maintenance companies supporting the ADA brigade. The responsible major commander (theater and corps) establishes policies and procedures for control of these float assets. The issue of items from float stocks is rigidly controlled. Within the ADA brigade, the brigade commander establishes policies and procedures for the control and use of float assets.

The authorized ORF for the ADA brigade is carried by the maintenance operating elements located in the brigade support area. Maintenance elements in the battalion trains areas are not normally capable of providing a float, although specific items may be retained by the battalion support elements. ORF assets must be accounted for, and ORF items should be

maintained in a ready-to-issue state by DS elements.

MAINTENANCE DEFINITIONS

Maintenance definitions are discussed below. These methods are used when required parts, components, or assemblies cannot be obtained in a timely basis through normal Class IX supply channels.

Controlled Exchange

Controlled exchange is authorized by battery commanders for the systematic removal of serviceable parts from unserviceable equipment for immediate use to restore a like item to readiness. When controlled exchange is practiced, the serviceable part is removed and replaced by the unserviceable part. Controlled exchange is performed at the organizational and intermediate maintenance levels.

Cannibalization

Cannibalization is authorized by the battalion commander for removal of

serviceable repair parts, components, or assemblies from unserviceable, uneconomically repairable, or excess end items of equipment authorized for disposal. It is a supply source for authorized low-mortality or difficult-to-obtain repair parts. Additionally, cannibalization is a source for high-priority items when delivery cannot be made by the required delivery date. It is also a source for items not stocked in the supply system. This function is normally performed at a cannibalization point. Cannibalization of organic equipment in a peacetime environment is not authorized.

Battle Damage Assessment

This is the process of assessing the status of damaged equipment. This function will be performed by trained battle damage maintenance personnel. They will make the critical decision whether the equipment will be repaired on-site, recovered, or evacuated. If the decision is to recover or evacuate it, the equipment is moved directly to maintenance units with the capability to repair it.

TRANSPORTATION

As the connecting link between other logistics functions, transportation moves personnel and materiel. A Patriot battalion is 100 percent mobile. However, higher echelon transportation moves repaired equipment from maintenance units to storage areas or using units, and moves supplies, including repair parts, where they are needed. It also moves personnel replacements from reception areas to combat units.

The transportation elements within a theater perform three functions: modal operations, terminal operations, and movement management. Modal operations move personnel or materiel in any conveyance by one of four modes: air, rail, road, or sea. Terminal operations shift cargo from one mode of transportation to another or from one

type of transport within a mode to a different type. The COSCOM provides integrated movement management and transportation support services through its CMCC and corps movement control teams (CMCTs). Light-medium or medium transportation truck companies are assigned or attached to corps support battalions as required, while a mix of light-medium and heavy truck companies are assigned or attached to the corps-level transportation battalion.

Command and control of the battalions is exercised by the corps support group (CSG). In the theater army, the Transportation Command (TRANSCOM) provides C² of attached or assigned motor transport units engaged in line-haul operations, and in support of the TAACOM supply and maintenance missions. The Theater

Army Movement Control Agency (TMCA) provides movement management and highway traffic regulation through its subordinate theater army regional movement control teams (RMCTs), movement regulating teams (MRTs), and air terminal movement control teams

(ATMCTs). Theater armymotor, aviation, rail, terminal service, and terminal transfer units operate in the COMMZ and combat rear area, as well as in the corps AO as required. Delivery and retrograde transportation services can be provided all the way into the division sector, if needed.

FIELD SERVICES

Field services are services required by units in the field but not usually available with the units. Field services generally include—

- Mortuary affairs.
- Airdrop.
- Bath.
- Clothing exchange.
- Laundry.
- Bakery.
- Textile renovation.
- Salvage.
- Decontamination.
- Clothing renovation.
- Post exchange sales.
- Provision of general duty labor.

These are generally divided into the classifications of primary and secondary field services.

The primary field services are those considered essential to the support of combat operations. Mortuary affairs and airdrop comprise the primary classification. These are necessary from the beginning to the end of hostilities. The Army must always take proper care of its dead. Airdrop is also essential. It provides a method of supply delivery that is responsive and fast enough to meet the demands of modern battle. Details on airdrop services are in FM 10-500-9. The secondary classification consists of those field services which are not immediately critical to combat operations. Details on laundry, bath, and renovation are in FM 10-280. Mortuary affairs procedures, controlled by the S4, can be found in FM 10-63-1. All procedures for field services must be covered in battalion SOPs.

REAR AREA PROTECTION

Rear area protection (RAP) includes rear area combat operations (RACO) and area damage control (ADC) activities. The purpose of RAP operations is to prevent interruption of combat, combat support, and CSS operations and to minimize the effects when interruptions occur as a result of enemy activity, sabotage, or natural disaster. Those actions taken to prevent, neutralize, or defeat hostile actions against units, activities, and installations in the rear area are RACO. ADC activities are those prevention and control measures taken prior to, during, and after an attack or a natural or man-made disaster to minimize its effects.

REAR AREA COMBAT OPERATIONS

The ADA brigade has defined responsibilities for RACO. The ADA brigade or battalion participates in RACO which is the responsibility of the corps or theater support commander. The RACO commander has tasking authority for all units within rear areas. The ADA brigade S3 has primary staff responsibility for rear AD planning and coordination for the brigade. In coordination with the S2 and S4, he plans and assigns ADA brigade RAP responsibilities for RACO.

Forces

Each unit provides its own local self-defense and assists in the defense. The battalion S3 may

be required to provide support operations with combat forces to secure critical areas and resupply routes, escort convoys, or counter hostile forces that threaten accomplishment of the support battalion mission. Surveillance and security for those areas not essential to accomplishment of the support battalion mission are the brigade's responsibility.

Measures

Unit personnel are trained by the battalion in basic defense techniques including passive AD measures and use of non-AD weapons against attacking aircraft. Communications and warning systems are established, SOPs are developed, and OPLANs for reaction forces are developed and rehearsed. Protection is provided for personnel, key activities, and essential lines of communications. Operations are dispersed, and defensive positions are prepared consistent with the effective execution of the mission. Other RAP measures employed include—

- Conducting a vulnerability analysis of the rear area to determine which battalion elements and facilities are the most vulnerable to enemy attack.
- Prescribing instructions for the coordination of local security plans of adjacent units.
- Employing an alert system to provide early warning and notice of enemy activity,
- Requesting armed aircraft escorts for resupply flights and armed escorts for surface convoys.
- Posting security elements from attached security forces at critical locations on the MSR.
- Employing local route reconnaissance and patrols.
- Enforcing light and noise discipline.
- Employing natural and artificial obstacles.

- Performing NBC reconnaissance, chemical detection, and radiological monitoring and survey operations.

- Coordinating with the battalion S2 to ensure adequate counterintelligence support for the detection, prevention, and neutralization of hostile intelligence threat.

- Coordinating with the appropriate local civilian and paramilitary authorities and forces. If control of the civilian population becomes a prime factor in RAP operations, a request may be submitted to the ADA brigade S3 for additional psychological operations support and military police support to control refugees and displaced personnel.

- Coordinating with the brigade S3 and with the military police unit for area security operations. These operations may include area reconnaissance, convoy security, security of critical points along MSRs, and chemical detection and radiological monitoring and survey operations along the MSRs.

When enemy activity exceeds the capability of Patriot units, military police provide the initial force to close with and destroy enemy forces. In the event of a large-scale enemy incursion, combat forces will be required to conduct RACO.

AREA DAMAGE CONTROL

The battalion S4 has primary staff responsibility for ADC within the battalion AO. The battalion S3 is responsible for the plans and activities necessary to reduce the effects of enemy attack or natural disaster on battalion elements. During the planning and supervising of ADC, the priority is on actions that prevent or reduce the interruption of CSS operations. The battalion commander and staff must be aware of any diversion of CSS elements to an ADC mission.

Forces

The personnel and equipment of subordinate units located in the area are the principal

ADC means available. Coordination with the brigade staff for engineer, military police, and signal support is essential in ADC activities. Locally procured resources and assistance from nonbrigade units located in the brigade support area (BSA) maybe available in some situations.

Measures

Area damage control measures include—

- Providing SOPs and implementing instructions for self-help.
- Designating, training, and employing firefighting, damage clearance, decontamination, rescue, food service, chemical detection, biological sampling, radiological survey, medical, chaplain, and repair personnel. Each unit will organize teams with appropriate skills and equipment.
- Assessing the extent and significance of damage and instituting area damage control measures to reduce the effects of losses in personnel, materiel, and facilities.
- Ensuring that coordination is made for military police to control traffic, conduct law enforcement, and protect designated personnel, facilities, units, and installations.
- Rerouting traffic, as required, to provide continual support to tactical elements and to facilitate the reduction of damage and contamination.
- Dispersing units and facilities to reduce their vulnerability to attack by enemy forces and nuclear, chemical, or biological weapons.
- Establishing warning procedures for prompt information dissemination of known or suspected attacks and natural disasters. Preparations must be undertaken to reduce vulnerability. The warning system should include fallout prediction, if appropriate.
- Coordinating battalion area damage control plans with local host nation authorities.

- Coordinating with other units located nearby for their roles in the area damage control mission.
- Establishing and coordinating a health service support (HSS) plan for mass casualty situations.

OPERATIONS SECURITY

Operations security (OPSEC) deals with protecting military operations and activities by identifying and eliminating or controlling intelligence indicators that the enemy could use. It is concerned with the protection of both classified and unclassified data that hostile intelligence agencies could process into military intelligence. It includes physical security, signal security (SIGSEC), and information security. OPSEC consideration must be a routine part of operations. It must become second nature to CSS planners and operators in all types of units and at all levels of command.

Modern military forces are increasingly dependent upon electronic devices for C², employment of forces, weapons security, and logistics support. This dependence makes them vulnerable to hostile actions designed to reduce the effectiveness of friendly communications-electronics (CE) devices. Command posts, weapon systems, and logistics bases cannot survive during force-projection operations if they are easily identified and located because of their electromagnetic emissions. Tactics which conceal emitters or deceive the enemy as to their identity and location are vital to successful operations.

Because of technical advances in intelligence collection, sensors, communications, and data processing, survival on the battlefield requires extensive countersurveillance. Countersurveillance must be a state of mind, a skill reduced to habit, where everyone practices camouflage, noise, light, litter, smoke, and communications discipline. OPSEC considerations must be included in all CSS plans.

RECONSTITUTION

The increasing capabilities and lethality of modern weapon systems greatly increase the chances of high losses of troops and equipment over short periods of time. The successor failure of Patriot units during the air attack depends upon their ability to reconstitute their combat power. The quality of prior planning will determine how quickly Patriot units will be able to reenter the air battle.

RECONSTITUTION PRINCIPLES

Reconstitution consists of nonroutine actions taken to restore damaged units to a specific-level of combat readiness. These nonroutine actions are based on priorities established by the battalion commander and result in the receipt of specified available resources to accomplish the reconstitution mission.

Commanders have two reconstitution options available for returning a unit to a specified level of combat capability.

Reorganization

Reorganization is accomplished within the unit. Reorganization consists of asset cross-leveling to form composite teams, sections, platoons, or higher-level units. Since reorganization is conducted internally, it is the most expedient means of maintaining combat power in the early stages of a conflict and in forward units throughout the duration of the conflict. It is the option most often executed by commanders.

Regeneration

Regeneration requires outside support. Regeneration consists of rebuilding a unit by infusing new personnel, equipment, and supplies into a unit and then conducting the necessary training to develop combat effectiveness.

Regeneration is the more difficult of the two available reconstitution options. It requires a great deal of both outside assistance and time for training. Commanders may choose regeneration as the method of reconstitution because regeneration can preserve the cohesion, trust, and confidence of the unit by infusing new personnel into existing squads and sections.

Reconstitution level. Patriot units should attempt to reconstitute at the lowest level possible based on the following considerations:

- Enemy situation.
- Size of the attrited unit.
- Personnel and resources available.
- Availability of ground or air transportation to move resources to the unit or vice versa.
- Future deployment plans for the reconstituted unit.

Reconstitution responsibility. This rests with the commander one level higher than the damaged unit. Reconstitution efforts flow from the platoon leader all the way to the theater commander.

RESPONSIBILITIES AT BATTERY LEVEL

The battery commander reestablishes the damaged unit's AD capability. A key ingredient for the return of unit command and control is the initiation of damage assessment leading to subsequent reconstitution efforts. Unit reconstitution points, the predetermined chain of command, decontamination procedures, and the requirements for determination of equipment operability following enemy attack must be addressed in detail in unit SOPs.

PRIORITIES

SOPs must also address specific priorities for reconstitution. Prioritization should always

be oriented towards reestablishing the combat power of the unit.

MEDICAL SUPPORT PROCEDURES

Medical support procedures are carried out as the unit attempts to reestablish C² within the unit and to higher headquarters. Soldiers perform buddy aid on wounded personnel, and unit teams initiate rescue, collection, identification, and separation of contaminated casualties. Combat medics triage, treat, and request evacuation of patients. Predesignated field ambulances evacuate the critically injured to the battalion aid station.

COMMANDER'S ASSESSMENT

The battery commander and key personnel determine soldier and equipment losses. The commander assesses the unit's capability to function in the air battle, and the unit forwards the information to the battalion using a standardized weapon system status report.

BATTLE DAMAGE CONTROL

The battle damage control team saves as much equipment as possible and estimates the requirement for further assistance. The damage control team forwards this estimate as part of the unit report.

DECONTAMINATION

In the presence of NBC agents, the unit conducts decontamination as soon as possible. The decision to do hasty or deliberate decontamination will depend on the situation, the extent of contamination, decontamination resources, and the mission. Only that which is

necessary to accomplish the mission is decontaminated.

SUPPORT UNIT RECONSTITUTION

The same basic reconstitution procedures apply to the DS unit. The battalion supply and equipment (BSE) manages the reconstitution of the DS maintenance unit. The scarcity of Patriot assets and ORFs makes DS maintenance unit reconstitution a critical priority.

SITE DETERMINATION

The battery and battalion commanders determine the best location for the reconstitution effort, whether on-site, at a jump location, at the reconstitution point at battalion, brigade, major AD command, or support command. For ground security purposes, the lowest level of reconstitution should be at the battalion. If reconstitution at battalion level is not feasible, the unit jump location should be near a main supply route, or should possess a landing site for C-141 aircraft.

RESPONSIBILITIES AT BATTALION LEVEL

The battalion commander is responsible for Patriot battery reconstitution. It is, however, primarily a staff activity (see the following checklist), and the battalion XO is the manager of the reconstitution effort. Based upon priorities set by the S3 and the commander, he manages and coordinates the activities of the S1, S2, CESO, headquarters battery commander, and DS unit commander. When the battalion receives the status report from one of the batteries, the XO and staff determine the severity of the situation, and the XO dispatches a battalion control and assessment team if he

deems it necessary. The XO briefs the battalion commander on the essential elements of the status report and on staff recommendations. The following is a staff checklist for reconstitution:

- S1—
 - Determines availability of replacements.
 - Coordinates personnel replacements.
 - Fills positions based on priorities set by S3.
 - Coordinates medical support.
- S2—
 - Provides threat assessments for rear area reconstitution sites.
 - Advises S3 on the threat situation.
- S3—
 - Recommends priorities for reconstitution to commander.
 - Identifies critical shortfalls.
 - Redesigns air defense based on available firepower.
 - Sets communications priorities.
 - Sets priorities for decontamination.
 - Sets priorities for resupply of Classes III and V (missile) by unit.
 - Monitors Patriot system repair actions.
 - Sets priorities for personnel replacements by MOS and unit.
 - Coordinates locations for hasty and deliberate decontamination.

- S4—
 - Recommends allocation of critical supply items.
 - Coordinates resupply of critical items (Classes I, III, V, and IX) according to the priorities.
 - Coordinates host nation support.
 - Coordinates movement requirements to support reconstitution.
 - Coordinates delivery of ORF equipment with the DS unit.

PLANNING AND TRAINING FOR RECONSTITUTION

The coordination between the AD chain of command and the corps or theater chain of command is critical. Standardization of procedures during exercises should be emphasized. Staff training in reconstitution procedures at all levels is essential to ensure success in wartime operations. Since Patriot resources are finite, “push-packs” under a program such as the preconfigured unit load program could reduce the transportation requirements for critical Patriot components in a corps area. The criteria and layout of reconstitution points should be addressed in detail in battalion and brigade OPLANs. This is because of the sheer number of activities which must occur.

APPENDIX A

BATTALION AND BATTERY CHECKLISTS

This appendix contains checklists to aid the battery commander and his chain of command. They are general in nature and should be used as a basis for additional requirements.

PREPARATION FOR COMBAT

These checklists are away to organize all the procedures unit personnel must perform in preparing for combat operations. These procedures deal with individual soldiers and all the materials for which they may be responsible.

SOLDIER'S CHECKLIST

1. TA-50 inventory. _____
2. Weapon cleaned and zeroed. _____
3. Briefed on—
 - a. Safety, including hearing and RF radiation. _____
 - b. Cold or heat injuries. _____
 - c. Situation and mission. _____
 - d. SOFA (Status of Forces Agreement). _____
4. Load-bearing equipment.
 - a. First aid kit. _____
 - b. Canteen with water. _____
 - c. Ammunition pouches and magazines. _____
 - d. M258A1/A2 kit. _____
 - e. Protective mask with combat filters and nerve agent antidote kit. _____
5. ID card and ID tags. _____
6. MOPP gear available. _____
7. Personal military clothing and hygiene items. _____

UNIT VEHICLE CHECKLIST

- 1. Publications for vehicles and equipment present. _____
- 2. Logbooks, dispatches, and load plan present. _____
- 3. Prime movers.
 - a. PMCS performed and deficiencies noted and corrected (DA Form 5988-E). _____
 - b. OVM present and serviceable. _____
 - c. Tire chains present and serviceable (weather dependent). _____
 - d. Fuel tank topped off. _____
 - e. Fuel can(s) present, full, secured, and properly marked. _____
 - f. Water can(s) present, full, and secured. _____
 - g. Fire extinguishers present, updated, and sealed. _____
 - h. First aid kit present and complete. _____
 - i. Unit designations covered. _____

TOWED LOAD CHECKLIST

- 1. PMCS performed and deficiencies noted and corrected (DA Form 5988-E). _____
- 2. Brake hose connectors clean, serviceable, operational, and properly marked. _____
- 3. Brakes checked with prime mover. _____
- 4. Lights operational. _____
- 5. Load properly secured or prepared for road march. _____
- 6. Safety chains present and serviceable. _____
- 7. Unit designations covered. _____

PATRIOT EQUIPMENT CHECKLIST

1. Publications for equipment present. _____
2. PMCS performed and deficiencies noted and corrected (DA Form 5988-E). _____
3. Data and power cables serviceable and all have cable covers. _____
4. Cable reels present and serviceable. _____
5. RL-31s present and serviceable. _____
6. Headsets and extension cable present, serviceable, and operational at all end items of equipment. _____
7. Radar prepared for movement. _____
8. Launcher/missile serviceability checks complete. _____
9. ECS, ICC, and CRG vans clean and free of debris. _____
10. AMG in march order configuration. _____
11. Ground rods and straps present and serviceable at all equipment. _____
12. Sledgehammers, 12- or 16-pound, present, serviceable, and available for all equipment. _____
13. PLL available and loaded per battery SOP. _____
14. M2 aiming circle present, serviceable, and operational. _____
15. M1 gunner's quadrant present, serviceable, and operational. _____
16. Current software version available and all spares present. _____
17. All equipment keys accounted for and available. _____
18. All fire extinguishers present with current inspection and sealed. _____
19. Current IFF/SIF, launcher station codes, and frequencies available. _____

POWER GENERATOR CHECKLIST

1. Publications for equipment present. _____
2. PMCS performed and deficiencies noted and corrected (DA Form 5988-E). _____
3. Fuel tanks full. _____
4. All covers present and properly secured. _____
5. Fire extinguisher present, updated, and sealed. _____
6. Check for oil, fuel, or hydraulic leaks. _____
7. Ground rod and strap present and serviceable. _____
8. Sledgehammer, 12- or 16-pound, present and serviceable. _____

COMMUNICATIONS EQUIPMENT CHECKLIST

1. Publications for equipment present. _____
2. PMCS performed and deficiencies noted and corrected (DA Form 5988-E). _____
3. Radios and intercom present and operational. _____
4. All connectors and receptacles clean and serviceable. _____
5. Grounding straps secure. _____
6. Equipment properly secured on vehicles and van. _____
7. Antennas, cables, and matching units complete and serviceable. _____
8. TA-312 or TA-1 present and serviceable. _____
9. IFF codebook present and codes loaded. _____
10. Applicable batteries and spares on hand. _____
11. AN/GRC-103 complete and operational. _____
12. AN/GRC-106 complete and operational. _____

COMMUNICATIONS EQUIPMENT CHECKLIST (CONTINUED)

- 13. SINCGARS and ancillary equipment complete and operational. _____
- 14. Compass. _____
- 15. Communications plan. _____

INDIVIDUAL- AND CREW-SERVED WEAPONS CHECKLIST

- 1. Publications for equipment present. _____
- 2. PMCS performed and deficiencies noted and corrected (DA Form 5988-E). _____
- 3. All weapons clean and serviceable. _____
- 4. All machine guns have spare barrels, cartridge extractor, asbestos gloves, and T&E mechanism. _____
- 5. 50-caliber machine gun headspace and timing correct, and headspace and timing gauge available and serviceable. _____
- 6. Weapons cleaning equipment on hand. _____
- 7. Basic load of ammunition available for issue for individual- and crew-served weapons. _____

MANPADS (STINGER) CHECKLIST

- 1. Publications for equipment present. _____
- 2. Vehicle PMCS performed and deficiencies noted and corrected (DA Form 5988-E). _____
- 3. IFF codebook present and codes loaded. _____
- 4. Basic load of missiles (3 BCUs per missile) present and secured on prime mover. _____
- 5. Basic load of MREs. _____
- 6. Spare IFF batteries present and serviceable. _____

MANPADS (STINGER) CHECKLIST (CONTINUED)

- 7. Basic load of fuel. _____
- 8. Programmer, interrogator set AN/GSX-1 IFF programmer (1 per 2 teams) available and operational. _____
- 9. Radios operational and keyed. _____
- 10. Code changing keys, KYK-13 generator (1 per 2 teams) available and serviceable. _____
- 11. Harness, transport, and guided missile equipment available and serviceable. _____
- 12. AC generator (1 per 2 teams) available and serviceable. _____

UNIT OPERATIONAL READINESS CHECKLIST

- 1. Battery alert plan current and functional. _____
- 2. Battery alert roster current. _____
- 3. Battery commander or first sergeant ensures—
 - a. Vehicles are loaded and secured according to load plan. _____
 - b. Vehicles topped off. _____
 - c. Vehicles have dispatches or logbooks. _____
 - d. Current PMCS and DA Form 5988-E. _____
 - e. All drivers have valid operator's license. _____
 - f. SOIs are current. _____
 - g. MRE rations properly distributed and resupply coordinated. _____
 - h. Plans and coordination for hot meals are made. _____
 - i. Plans and coordination for refueling are made. _____
 - j. Key personnel briefed. _____

UNIT OPERATIONAL READINESS CHECKLIST (CONTINUED)

- k. SINCGARS loaded with appropriate codes. _____
- l. Warning order issued. _____
- m. Spot-checks of equipment, personnel, and individual knowledge conducted. _____
- n. Shower and laundry facilities have been located and coordination completed. _____
- o. Rehearsals as needed. _____

BATTERY COMMANDER'S CHECKLIST

- 1. Manuals, according to TSOP. _____
- 2. Maps adrlays in map case. _____
- 3. Grease pencils and acetate. _____
- 4. Flashlight with red filter and extra BA-30s. _____
- 5. Watch. _____
- 6. TSOPs.
 - a Theater. _____
 - b. Brigade. _____
 - c. Battalion. _____
 - d. Battery. _____
- 7. OPORD/graphies. _____
- 8. Blank forms as needed. _____

BRIEFING CHECKLIST

1. Situation:

- a. Information on threat and friendly situation. _____
- b. Terrain and expected weather. _____
- c. Supported unit's mission and objectives. _____
- d. Location of Patriot units and other ADA units in area. _____

2. Mission:

- a. Explain unit mission. _____
- b. Explain what is expected of battery. _____

3. Execution:

- a. Explain tactical plan. _____
- b. Assign and explain section or individual tasks as necessary. _____

4. Service support:

- a. Administrative. _____
- b. Rations. _____
- c. Ammunition (conventional and missile). _____
- d. Medical. _____
- e. Casualty evacuation. _____
- f. POL and water. _____
- g. Class II, IV, and IX supplies. _____

5. Command and signal:

- a. EMCON SOE. _____
- b. Radio frequencies (primary and alternate) and call signs. _____

BRIEFING CHECKLIST (CONTINUED)

- c. CP location (battery, battalion, and supported unit). _____
- d. Chain of command. _____

RSOP CHECKLIST

1. Briefing:

- a. Primary, alternate, and supplemental locations and routes. _____
- b. Terrain and environment (weather and NBC). _____
- c. EMCON SOE. _____
- d. Radio frequencies and call signs. _____
- e. Action to take if attacked. _____
- f. Answer questions. _____
- g. Movement time. _____
- h. Uniform for movement (MOPP). _____
- i. Strip maps. _____
- j. Discuss convoy procedures (see Convoy Checklist). _____
- k. System emplacement parameters. _____
- l. Trig tables and basic load of maps for the area. _____

2. Personnel.

- a. OIC and NCOIC. _____
- b. Driver/RTO. _____
- c. Security team. _____
- d. Equipment guides also make up minesweeping team, NBC team, and reaction force. _____
- e. Communications personnel (VHF operator and tactical wireman). _____

RSOP CHECKLIST (CONTINUED)

f. Road guides. _____

3. Equipment.

a. Truck, cargo, 2 1/2-or 5-ton, 6x6. _____

b. Truck, utility, with radio set, SINCGARS. _____

c. Mine detector, metallic, AN-PSS-11. _____

d. Batteries for mine detector. _____

e. Chemical agent automatic alarm,
power supply, and M256 kit. _____

f. Radiacmeter, AN-VDR-2. _____

g. Telephone set, TA-312/PT or TA-1. _____

h. Antenna group OE-254 or equivalent. _____

i. WD1 telephone cable. _____

j. Measuring tape. _____

k. Marking stakes and sledgehammer. _____

l. M2 aiming circle. _____

m. Equipment for preparation of coverage diagrams. _____

n. Maps of area. _____

o. Binoculars. _____

p. Camouflage screen systems. _____

q. Individual weapons and ammunition. _____

r. Two M203s and ammunition. _____

s. Individual protective and load-bearing equipment. _____

t. Machine gun, 7.62-mm, with tripod and extra barrel. _____

u. Night vision sight, individual-served weapon,
AN/PVS-4. _____

v. Rations and water for 3 days minimum. _____

RSOP CHECKLIST (CONTINUED)

- w. POL for 3 days minimum. _____
 - x. SOL. _____
 - y. NBC marker kit. _____
 - z. Ground rods. _____
 - aa. MOPP gear with individual decontamination kit. _____
4. Route Acceptability.
- a. Overhead clearance. _____
 - b. Roadway width and trafficability. _____
 - c. Bridge classification. _____
 - d. Forging sites. _____
 - e. Areas available for dispersion. _____
 - f. Easily distinguishable landmarks. _____
 - g. Cover and concealment. _____
 - h. Route clear of mines and NBC hazards. _____
5. Location Acceptability.
- a. Size of area (1-km square). _____
 - b. Slope less than 10 degrees. _____
 - c. Radar FOV along PTL (radar clutter). _____
 - d. Clear field of fire. _____
 - e. Cover and concealment. _____
 - f. Surface firmness (consider weather). _____
 - g. Accessibility. _____
 - h. Free of mines and NBC hazards. _____

RSOP CHECKLIST (CONTINUED)

6. Position Layout (coordinate with survey team).

- a. Determine PTL and known reference points (KRPs). _____
- b. Disperse equipment. _____
- c. Radar has terrain priority. _____
- d. LOS exists for alignment (preferred). _____
- e. Equipment positioned within cable lengths. _____
- f. ECS door faces away from radars. _____
- g. Generators positioned to minimize radar interference. _____
- h. CP location close to ECS. _____
- i. Ground security within platoon capabilities (area considered). _____

STAFF COORDINATION CHECKLIST

1. S3:

- a. Front line trace. _____
- b. Friendly air and ground situation. _____
- c. AD assets available in AO. _____
- d. Coordinates integration of early warning as applicable.
 - (1) To SHORAD units. _____
 - (2) From other Patriot units. _____
 - (3) From USAF sensors. _____

Note: Coordinate integration of Patriot air picture to provide early warning to Hawk and SHORAD assets. Also check for sharing of air picture from USAF sensors.

STAFF COORDINATION CHECKLIST (CONTINUED)

- 2. S2:
 - a. Current enemy situation. _____
 - b. Intelligence requirements. _____
- 3. NBC officer
 - a. NBC situation. _____
 - b. Location of deliberate or hasty decontamination points. _____
- 4. CE officer:
 - a. Current communications plan, SOI requirements, and changes. _____
 - b. CRG status and locations. _____
 - c. Battalion multichannel capabilities and operability. _____
 - d. EW activity. _____
 - e. EMCON parameters. _____
- 5. S4:
 - a. Coordinates rations. _____
 - b. Coordinates POL. _____
 - c. Coordinates ammunition resupply (conventional and missile). _____
 - d. Coordinates other classes of supplies as needed. _____
 - e. Deconflicts terrain use. _____
 - f. Coordinates movements. _____

GROUND DEFENSE CHECKLIST

- 1. Positions have cover and concealment and are continuously improved. _____

GROUND DEFENSE CHECKLIST (CONTINUED)

- 2. Positions have communications with CP. _____
- 3. Positions have range cards with overlapping fields of fire. _____
- 4. Positions are located a sufficient distance from equipment for RF and backblast safety. _____
- 5. Evaluate for gaps in defense. _____
- 6. Entry control point established. _____
- 7. OP/LP/patrol. _____
- 8. Barrier plan. _____
- 9. Crew-served weapons and M203s cover likely AOs. _____
- 10. Reaction force NCOIC, personnel, weapons, and rally point identified. _____
- 11. Reaction force has manpack communications available, serviceable, and operational with spare batteries. _____
- 12. Communications equipment used in perimeter defense is operational with spare batteries. _____
- 13. Ensure perimeter personnel know challenge and password. _____
- 14. Ensure SOI and EMCON SOE are known and adhered to. _____
- 15. Establish communications and integrate perimeter defense with adjacent units when the situation dictates. _____
- 16. Perimeter sketch is drawn and posted in the CP. _____
- 17. Establish 24-hour defense plan to include LPs/OPs, roving guards, patrols, and BMNT/EENT. _____

CP CHECKLIST

- 1. Locate the CP to ensure communications with—
 - a. ECS (ICC for BTOC). _____

CP CHECKLIST (CONTINUED)

- b. Perimeter guard posts. _____
- c. Maintenance team. _____
- d. MANPADS teams. _____
- e. Adjacent units (ground or AD). _____
- 2. CP location checked for NBC hazards prior to occupation. _____
- 3. Use available cover and concealment or camouflage. _____
- 4. Establish communications with CP per EMCON parameters. _____
- 5. Observe COMSEC and ECCM procedures:
 - a. Adhere to EMCON parameters. _____
 - b. Enter net per SOI and SOP. _____
 - c. Operate in assigned net. _____
 - d. Establish required nets. _____
 - e. Enforce net discipline. _____
- 6. Submit reports as required. _____
- 7. Follow maintenance SOP to ensure quick response. _____
- 8. Follow and execute all aspects of OPORD. _____
- 9. Plan, coordinate, and request resupply of all supply classes as necessary. _____
- 10. Know the following and exchange with higher, adjacent, and subordinate units:
 - a. Front line trace. _____
 - b. Friendly air and ground situation. _____
 - c. Enemy air, ground, NBC, and EW situation. _____

CP CHECKLIST (CONTINUED)

- d. Location of decontamination points. _____
- e. SOI requirements and changes. _____
- f. EEI or priority intelligence requirement. _____
- 11. Pass all urgent information to higher, adjacent, and subordinate units. _____
- 12. Know and display on map all units in the battalion. _____
- 13. Brief successor on plans and operations so he can take over in your absence. _____
- 14. Ensure battery performs proper PMCS. _____
- 15. Ensure adequate security measures are taken for classified documents and other sensitive items. _____

CONVOY CHECKLIST

- 1. Air defense coverage is maintained by MANPADS per TSOP. _____
- 2. Ground security is maintained per TSOP. _____
- 3. Drivers and assistant drivers are briefed on—
 - a. Safety. _____
 - b. Speed during convoy. _____
 - c. Routes, primary and alternate; SPs; checkpoints; and RPs (marked on strip map). _____
 - d. Action if attacked by air or ambushed (blocked/unblocked). _____
 - e. Action if vehicle malfunctions. _____
 - f. Action during halts. _____
 - g. Responsibilities of trail vehicle. _____
 - h. Air guard responsibilities. _____

CONVOY CHECKLIST (CONTINUED)

- 4. Vehicles, trailers, and loads checked, corrections on the spot (Patriot equipment march ordered properly). _____
 - 5. Vehicles formed in order of march. _____
 - 6. Vehicle and trailer:
 - a. Unit markings covered. _____
 - b. All mirrors and lights uncovered so as not to impair driving operations. _____
 - c. Lights operational. _____
 - d. Brakes operational. _____
 - e. Fuel tanks full. _____
 - f. Fuel and water cans present, full, and properly marked. _____
 - g. Floors sandbagged (vehicles only). _____
 - 7. MANPADS teams briefed on convoy AD coverage. _____
 - 8. Convoy movement control frequencies and call signs. _____
 - 9. Signals used during day or night movement. _____
-

MILVAN STORAGE AND SHIPPING

Patriot missiles delivered by theater transportation assets directly to the Patriot battalion area may be delivered in military vans (MILVANs). These checklists are procedures for loading and unloading of MILVANs.

MILVAN UNLOAD CHECKLIST

CHECKLIST 1

MILVAN UNLOAD/ISOLATION FRAME REPOSITIONING

Notes:

1. The unload checklist procedure is for battalion(s) that have 10,000-pound forklifts available for use.
2. Two forklifts should be used when performing unload procedures to minimize crucial time requirements.
3. Forklift PMCS must be performed before, during, and after operations for safety.
4. It is the responsibility of the S4 to provide MILVAN unload emergency procedural training for fire unit personnel for possible missile(s) airlift situations.
5. Ensure that the terrain on which the missile(s) movement operation is going to take place is level and firm.
6. Never attempt to change direction (forward or reverse) until the forklift has come to a complete stop.
7. If the missile(s) starts rocking while on the forklift forks, slowly bring the forklift to a complete stop.

DANGER

Do not stand under or in path of raised load. Serious injury or death may result if struck by moving load.

WARNING

Two ground guides are required at all times to safely move missile(s) with the use of a forklift.

Use of fire extinguishers are for preventing missile fires. Once missile fire is evident, crew members are to evacuate and secure the area. Do not fight missile fire.

Crew members must be watched by other crew members and warned of unsafe condition to prevent injury.

References required:

a. TM 10-3930-243-12

b. TM 10-3930-643-10.

PART 1: MILVAN (Unload)

Four crew members and the following equipment are required:

- a. Forklift, 10,000-pound lift, 2 each (full articulating mechanisms). _____
- b. 10,000-pound load-tested chains, 2 each. _____
- c. Helmets, 4 each. _____
- d. Goggles, 4 pairs. _____
- e. Hearing protection, 4 pairs. _____
- f. Gloves, 4 pairs. _____
- g. 4x4 lumber, 4 feet long, 2 each. _____
- h. Fire extinguisher, 10BC, 2 each. _____
- i. Crowbars, 2 each. _____
- j. 3/4-inch socket wrench, 1 each. _____
- k. Speed handle, 3/4-inch or 2-inch, 1 each. _____
- l. Torque wrench, 60-pound, 1 each. _____
- m. 2x4 lumber, 5 feet long, 2 each. _____
- n. 3/4-inch box/open-end wrench, 1 each. _____

PART 2: Isolation Frame Repositioning

Four crew members and the following equipment are required:

- a. Forklift, 10,000-pound lift, 1 each (full articulating mechanisms). _____
- b. Helmets, 4 each. _____
- c. Goggles, 4 pairs. _____
- d. Hearing protection, 4 pairs. _____
- e. Gloves, 4 pairs. _____
- f. Fire extinguisher, 10BC, 2 each. _____
- g. Crowbars, 2 each. _____

- h. 3/4-inch socket wrench, 1 each. _____
- i. Speed handle, 1 each. _____
- j. Torque wrench, 1 each. _____
- k. 2x4 lumber, 5 feet long, 2 each. _____
- l. 3/4-inch wrench, 1 each. _____

PART 1: Forklift (Unload)

Assign crew members:

- a. Licensed 10,000-pound forklift operator(s). _____
- b. Ground guide/safety/signaler. _____
- c. Positioner/safety/ground guide, 2 each. _____

PART 2: Isolation Frame Repositioning

- 1. Assign crew members:
 - a. Bolt remover/installer. _____
 - b. Holder, 2 each. _____
 - c. Tool controller. _____
- 2. Place one fire extinguisher on either side of the MILVAN at predetermined points, in case of fire. _____

DANGER

Shorting plug(s) must be connected to each live guided missile(s) (GM) at A1J1. Otherwise, static charges may explode ordnance devices, resulting in injury or death.

Damaged canisters can indicate unusable missile(s). Report any canister(s) damage immediately. Battalion commander will decide to replace or use.

WARNING

When handling wooden items, gloves and goggles must be worn at all times to prevent injury.

PART 1: MILVAN Unload Checklist Procedure

Note: In the event that missile canister load procedures must be performed, it is recommended that blocking material from the MILVANS be stored for future use.

1. Open and prepare MILVAN for unload:
Remove all blocking material from inside MILVAN and check center blocking material to ensure which canister(s) to pull out first. _____
2. Visually inspect canister(s) for damage. Record and report damage, if any. _____

DANGER

Do **not** leave forklift unattended without chocking wheels. Forklift may roll, resulting in injury or death.

Do **not** stand under or in path of raised load. Serious injury or death may result if struck by moving load.

WARNING

Ensure forklift travel speed does **not** exceed ground guides' normal walking pace.

Do **not** elevate or lower guided missile (GM) canister(s) while forklift is in motion.

To prevent injuries, ensure that all personnel are clear before moving forklift.

CAUTION

Operation of this equipment presents a noise hazard to personnel in the area. The noise level exceeds the allowable limits for unprotected ears. Ear muffs or ear plugs must be worn when operating or working around this machinery.

3. Ensure all crew members are wearing the proper hearing protection. _____
4. Perform before-operation PMCS on 10,000-pound forklift(s). _____

WARNING

To prevent accidental movement of the forklift, apply parking/emergency brake, and place transmission directional lever in neutral position lock.

Operator must wear seat belt at all times during operation of forklift.

WARNING
Observe operations for safety hazards.
Forklifts carrying munitions must travel in straight lines (with minimal turns).

5. Position forklift 1:

- a. Signal forklift operator 1 to move within 8 inches of canister end. _____
- b. Ground-guide forklift to within 8 inches of canister end. _____
- c. Forklift operator 1 moves forklift within 8 inches of canister end. _____

Note: When parking forklift, ensure forklift is on level ground, lower forks to the ground, move the lock over the transmission lever, and stop engine according to proper TM procedures.

6. Position forklift 2:

- a. Signal forklift operator 2 to safe area to prepare for side-lift loading. _____
- b. Ground-guide forklift for preparation of side-lift loading. _____
- c. Forklift operator 2 moves to preparation area for side-lift loading, then chocks vehicle and assists other crew members. _____

7. Connect forklift to canister(s):

- Hook chains from forklift through rear end of isolation frame lower loops. _____

Note: Crowbars may be necessary to assist in the movement of canister(s) during initial pull.

WARNING
Observe operations for safety hazards.

8. Pull canister(s):

- a. Signal forklift operator 1 to pull canister approximately 2 feet out of the MILVAN. _____
- b. Ground-guide forklift. _____
- c. Forklift operator 1 pulls canister(s) out of MILVAN approximately 2 feet. (Part of isolation frame will be inside of the MILVAN.) _____

DANGER

Use extreme care when placing the 4x4 lumber beneath raised canister(s). Falling canister(s) may result in loss of limb or death.

9. Position 4x4 lumber:

Position one 4x4 piece of lumber 4 feet in length beneath the extended part of the isolation frame.

Note: Ensure 4x4 lumber used remains at present position during canister(s) removal from MILVAN.

10. Chain tension:

a. Signal forklift operator 1 to release chain tension by driving forward.

b. Forklift operator 1 drives forward to release chain tension.

c. Unhook chain from isolation frame lower loops.

WARNING

Keep hands and feet away from forklift forks to prevent injury.

Observe operations for safety hazards.

Note: Use of chains to restrain lateral movement of missile canister is strongly recommended throughout the entire operation.

11. Forklift forks placement:

a. Signal forklift operator 1 to place forks under lower isolation frame.

b. Have a crew member assist in guiding forklift forks under the lower isolation frame from opposite side of canister.

c. Forklift operator 1 moves forklift forks under lower isolation frame.

d. Reconnect chains to prevent lateral movement of canister(s).

12. Lift canister(s):

a. Signal forklift operator 1 to raise canister(s) approximately 6 inches.

- b. Forklift operator 1 raises canister(s) approximately 6 inches.

13. Remove canister(s):

- a. Signal forklift operator 1 to pull canister(s) out of the MILVAN until approximately 8 inches of forward isolation frame is left inside the MILVAN.
- b. Ground-guide forklift pulling canister(s).
- c. Forklift operator 1 pulls canister(s) out of MILVAN until approximately 8 inches of the forward isolation frame is left inside the MILVAN.

DANGER

Use extreme care when placing the 4x4 lumber beneath raised canister(s). Falling canister(s) may result in loss of limb or death.

WARNING

Observe operations for safety hazards.

14. Position 4x4 lumber:
Position one 4x4 piece of lumber 4 feet in length beneath the rear lower isolation frame.

DANGER

Firmly seat canister(s) on 4x4 lumber to prevent canister(s) from tipping, which may result in injury or death.

15. Lower canister(s):

- a. Signal forklift operator 1 to release tension on chain, and slowly lower canister(s) onto the 4x4 lumber.
- b. Forklift operator 1 releases chain tension and slowly lowers canister(s) onto 4x4 lumber.

DANGER

Do not leave forklift unattended without chocking wheel. Forklift may roll, resulting in injury or death.

Do not stand under or in path of raised load. Serious injury or death may result if struck by moving load.

WARNING

Ensure forklift travel speed does not exceed ground guides' normal walking pace.
 To prevent injuries, ensure that all personnel are clear before moving forklift.
 Observe operations for safety hazards.

16. Release canister(s):

- a. Unhook chains from lower isolation frame. _____
- b. Signal forklift operator 1 to slowly disengage from the canister(s). _____
- c. Ground-guide forklift to a safe distance away from canister(s). _____
- d. Forklift operator 1 slowly disengages from canister(s) and backs away to a safe distance. _____

Note: Position forklift 2 forks fully to the opposite lateral position from the lateral movement required.

17. Prepare forklift 2 for side-lift:

- a. Signal forklift operator 2 to laterally position forklift forks accordingly. _____
- b. Forklift operator 2 positions forks to facilitate canister(s) lifting. _____

18. Forklift 2 movement:

- a. Signal forklift operator 2 to move towards canister(s). _____
- b. Ground-guide forklift operator 2 towards canister(s). _____
- c. Forklift operator 2 moves towards canister(s). _____

19. Side-lift canister(s):

- a. One soldier must be on the opposite side of the canister(s) to ensure forks do not extend 6 inches past the canister(s) forklift cavities. _____

WARNING

Observe operations for safety hazards.

- b. Signal forklift operator 2 to insert forks into canister(s) forklift cavity, raise canister(s) slowly approximately 6 inches and move forks laterally to clear canister(s) from MILVAN. _____
 - c. Forklift operator 2 inserts forks into canister(s) forklift cavity and slowly raises canister(s) approximately 6 inches. _____
 - d. Forklift operator 2 moves forks laterally to clear canister(s) from MILVAN. _____
20. Remove both 4x4 pieces of lumber from the drive path of forklift 2. _____
21. Move canister(s):
- a. Signal forklift operator 2 to raise canister(s) to traveling height of approximately 12 inches. _____
 - b. Ground-guide forklift operator 2 to canister(s) isolation frame repositioning area. _____
 - c. Forklift operator 2 raises canister(s) to traveling height and moves to the isolation frame repositioning area. _____
22. Position canister(s) in a safe area and on level ground. _____
- Notes:
- Remove center dunnage prior to the removal of additional canister(a).
 - In the event that missile canister load procedures have to be performed, it is recommended that blocking material from previous MILVANS be stored for future use.
23. Repeat steps 1 through 22 for additional canister(s) unload. _____
24. Proceed to isolation frame repositioning checklist procedure. _____

WARNING

When handling wooden items, gloves and goggles must be worn at all times to prevent injury. Isolation frame weight is 126 pounds and requires a two-man lift.

PART 2: Isolation Frame Repositioning Checklist Procedure

- Notes:
- Guided missile canister(s) must be positioned on a wooden support to reposition isolation frames.
 - This checklist is designed for repositioning the isolation frames for single-stacked canisters. If two canisters are stacked on top of each other, start isolation frame repositioning with the upper canister.

1. Use forklift operator 2 and position canister(s) on wooden support. Have forklift operator 2 move to safe position. _____
2. Place one fire extinguisher at each end of canister(s) in case of fire. _____
3. Loosen bolts from isolation frame:
 - a. Issue 3/4-inch wrench. _____
 - b. Hold isolation frame in place. _____
 - c. With 3/4-inch wrench, loosen all isolation frame mounting bolts (bottom bolts first, followed by upper bolts). _____

Note: When removing isolation frames from a two-canister stack, place the upper isolation frames on the 2x4 lumber flat on the ground.

4. Remove isolation frame mounting bolts:
 - a. Issue speed handle. _____
 - b. Hold isolation frame in place. _____
 - c. With speed handle, remove bottom isolation frame mounting bolts and then remove upper isolation frame mounting bolts. _____
5. Remove isolation frame and rotate 180 degrees. _____

Note: When installing isolation frame mounting bolts, remember to place the rubber mounting pads between the isolation frame and the canister(s).

6. Install upper and lower isolation frame mounting bolts and tighten hand-tight. _____

Note: Make use of 2x4 lumber to assist in positioning isolation frame as needed.

7. Tighten isolation frame mounting bolts:
 - a. Issue speed handle. _____
 - b. Hold isolation frame in place. _____
 - c. Tighten isolation frame mounting bolts. _____

Notes:

- After canister lower isolation frames are repositioned and bolts tightened, install upper canister isolation frame.
- Bolts must be torqued in the following sequence: upper left, lower left, upper right, and lower right.

8. Torque isolation frame mounting bolts:

a. Issue torque wrench with 3/4-inch socket wrench. _____

b. Torque isolation frame mounting bolts to 45 pounds. _____

9. Repeat steps 1 through 8 for the remaining isolation frames repositioning. _____

10. Perform after-operation PMCS on 10,000-pound forklift. _____

Note: The missile canister(s) is (are) now ready for fire unit missile(s) reload.

MILVAN LOAD CHECKLIST

CHECKLIST 2 ISOLATION FRAME REPOSITIONING/ MILVAN LOAD CHECKLIST PROCEDURE

Notes:

- Prior to performing load procedure, isolation frame repositioning must be performed.
- The load checklist procedure is for battalions that have 10,000-pound forklifts available for use.
- Two forklifts should be used when performing load procedures to minimize crucial time requirements.
- Forklift PMCS must be performed before, during, and after operations for safety.
- It is the responsibility of the battalion S4 to provide MILVAN load emergency procedural training for fire unit personnel for possible missile(s) airlift situations.
- Ensure that the terrain on which the missile movement operation is going to take place is level and firm.
- Never attempt to change direction (forward or reverse) until the forklift has come to a complete stop.

References required:

- a. TM 10-3930-243-12. _____
- b. TM 10-3930-643-10. _____

PART 1: Isolation Frame Repositioning

Four crew members and the following equipment are required:

- a. Forklift 10,000-pound lift (full articulating mechanism), 2 each. _____
- b. Fire extinguisher, 10BC, 2 each. _____
- c. Hearing protection, 4 pairs. _____
- d. Helmet, 4 each. _____
- e. Goggles, 4 pairs. _____
- f. Gloves, 4 pairs. _____
- g. 3/4-inch socket wrench, 1 each. _____
- h. Speed handle, 3/4-inch or 1/2-inch, 1 each. _____
- i. Torque wrench, 60-pound, 1 each. _____
- j. 3/4-inch box/open-end wrench, 1 each. _____
- k. 2x4 lumber, 5 feet long, 1 each. _____
- l. 4x4 lumber, 4 feet long, 2 each. _____

PART 2: MILVAN Load

Four crew members and the following equipment are available:

- a. Forklift, 10,000-pound lift (full articulating mechanisms), 2 each. _____
- b. 10,000-pound load-tested chains, 2 each. _____
- c. Fire extinguisher, 10BC, 2 each. _____
- d. Hearing protection, 4 pairs. _____
- e. Helmet, 4 each. _____
- f. Goggles, 4 pairs. _____
- g. Gloves, 4 pairs. _____
- h. 3/4-inch socket wrench, one each. _____
- i. Speed handle, 1 each. _____
- j. Torque wrench, 1 each. _____
- k. 3/4-inch wrench, 1 each. _____
- l. 2x4 lumber, 5 feet long, 1 each. _____
- m. 4x4 lumber, 4 feet long, 2 each. _____
- n. Crowbars, 2 each. _____

PART 1: Isolation Frame Repositioning

Assign crew members:

- a. Bolt remover/installer _____
- b. Holder, 2 each. _____
- c. Tool controller. _____

PART 2: Forklift (Load)

Assign crew members:

- a. Licensed 10,000-pound forklift operator(s). _____
- b. Ground guide/safety/signaler. _____
- c. Positioner/safety/ground guide, 2 each. _____

PART 1: Isolation Frame Repositioning Checklist Procedure

Note: Guided missile canister(s) must be positioned on a wooden support to reposition isolation frames.

WARNING

To prevent accidental movement of the forklift, apply parking/emergency brake and place transmission directional lever in neutral position and lock.

Seat belt must be fastened at all times during operation of forklift.

Observe operations for safety hazards.

Forklifts carrying munitions must travel in straight lines with minimal turns.

Ensure forklift travel speed does not exceed ground guides' normal walking pace.

Do not elevate or lower guided missile (GM) canister(s) while the forklift is in motion.

CAUTION

Operation of this equipment presents a noise hazard to personnel in the area. The noise level exceeds the allowable limits for unprotected ears. Ear muffs or ear plugs must be worn when operating or working around this machinery.

- 1. Ensure all crew members are wearing the proper hearing protection. _____
- 2. Perform before-operation PMCS on 10,000-pound forklift(s). _____

3. Position forklift 1:

- a. Signal forklift operator 1 to move to isolation frame repositioning area for side-lift of canister(s) onto wooden support. _____
- b. Ground-guide forklift operator 1 to isolation frame repositioning area. _____
- c. Forklift operator 1 moves forklift to isolation frame repositioning area and prepares for canister(s) side-lift. _____

WARNING

Ensure forklift travel speed does not exceed ground guides' normal walking pace.
To prevent injuries, ensure that all personnel are clear before moving forklift.
Observe operations for safety hazards.

CAUTION

Damaged canister(s) can indicate an unusable missile. Report canister(s) damage immediately.

4. Visually inspect canister(s) for damage. Report damage, if any. _____

Note: Guided missile canister(e) must be positional on a wooden support to reposition isolation frames.

5. Side-lift canister(s):

- a. Have one soldier on the opposite side of the canister(s) to ensure forks do not extend 6 inches past the canister(s) forklift cavities once the forks have been inserted into the forklift cavities. _____
 - b. Signal forklift operator 1 to insert forks into canister(s) forklift cavities; raise canister(s) slowly. _____
 - c. Forklift operator 1 inserts forks into canister forklift cavities and slowly raises canister. _____
6. Position canister on wooden support. Have forklift operator 1 move to a safe area. _____
7. Place one fire extinguisher at each end of canister(s) in case of fire. _____

WARNING

When handling wooden items, gloves and goggles must be worn at all times to prevent injury. Isolation frame weight is 126 pounds and requires a two-man lift.

Note: This checklist is designed for repositioning the isolation frames for single-stacked canisters. If two canisters are stacked on top of each other, start isolation frame repositioning with the upper canister.

8. Loosen bolts from isolation frame:

- a. Issue 3/4-inch wrench. _____
- b. Hold isolation frame in place. _____
- c. With 3/4-inch wrench, loosen all isolation frame mounting bolts (bottom bolts first, followed by the top bolts). _____

Note: When removing isolation frame from a two-canister stack, place the upper isolation frame on the 2x4 lumber flat on the ground.

9. Remove isolation frame mounting bolts:

- a. Issue speed handle. _____
- b. Hold isolation frame in place. _____
- c. With speed handle, remove bottom isolation frame mounting bolts and then remove upper isolation frame mounting bolts. _____

10. Remove isolation frame and rotate 180 degrees. _____

Note: When installing isolation frame mounting bolts, remember to place the rubber mounting pads between the isolation frame and the canister(s).

11. Install isolation frame mounting bolts and tighten hand-tight. _____

12. Tighten isolation frame mounting bolts:

- a. Issue speed handle. _____
- b. Hold isolation frame in place. _____
- c. Tighten isolation frame mounting bolts. _____

Notes:

- After lower canister isolation frames are repositioned and bolts tightened, pick up upper canister isolation frames and install them.
- Bolts must be torqued in the following sequence: upper left, lower left, upper right, and lower right.

13. Torque isolation frame mounting bolts:

- a. Issue torque wrench with 3/4-inch socket wrench. _____
- b. Torque isolation frame mounting bolts to 45 pounds. _____

14. Repeat steps 3 through 13 for the remaining isolation frames repositioning.

Note: The missile canister(s) is (are) now ready for MILVAN loading.

<p>WARNING</p> <p>Ensure forklift travel does <u>not</u> exceed ground guides' normal walking pace.</p> <p>To prevent injuries, ensure that all personnel are clear before moving forklift.</p> <p>Observe operations for safety hazards.</p>
--

15. Repeat step 3 to side-lift canister(s). _____

16. Move canister(s):

- a. Signal forklift operator 1 to raise canister(s) to traveling height, approximately 12 inches. _____
- b. Ground-guide forklift operator 1 to MILVAN to perform load procedure. _____
- c. Forklift operator 1 raises canister(s) to traveling height and moves towards MILVAN area. _____

17. Proceed to load checklist procedure.

<p>DANGER</p> <p>Do <u>not</u> stand under or in path of raised load; serious injury or death may result if struck by moving load.</p> <p>Shorting plug(s) must be connected to each live guided missile (GM) at A1J1. Otherwise, static charges may explode ordnance devices, resulting in injury or death.</p>

WARNING

Two ground guides are needed at all times to safely move missiles with the use of a forklift.
 When handling wooden items, gloves and goggles must be worn at all times to prevent injury.
 To prevent injuries, ensure that all personnel are clear before moving forklift.
 Crew members must be watched by other crew members and warned of unsafe conditions to prevent injury.

CAUTION

Damaged canister(s) can indicate an unusable missile. Report any canister(s) damage immediately.

18. Place one fire extinguisher on each side of the MILVAN in case of fire. _____

PART 2: Load Checklist Procedure

Note: Use previously stored blocking material for load procedure.

1. Open and prepare MILVAN for load:
 Ensure that the necessary blocking and center alignment materials are properly placed and secured to MILVAN. _____

Notes:

- Ensure that the forklift “push” assembly is properly attached and secured to the forklift forks of forklift 2.
- When parking forklift, ensure forklift is on level ground. Lower forks to the ground, move the lock over the transmission lever, and stop engine according to proper TM procedures. Position forward end of canister(s) in MILVAN and rear end of canister(s) at the MILVAN entry opening.

2. Position forklift 2:

- a. Signal forklift operator 2 to safe area to prepare for canister(s) insertion into the MILVAN. _____
- b. Ground-guide forklift operator 2 to safe area. _____
- c. Forklift operator 2 moves to safe area, then chocks vehicle and assists other crew members. _____

Notes:

- Position forklift 1 forks fully to the opposite lateral position from the lateral movement required.
- Ensure rear end of canister(s) is at MILVAN opening after insertion.

3. Move canister(s) laterally:

- a. Signal forklift operator 1 to laterally position forks accordingly to facilitate canister(s) insertion into the MILVAN. _____
- b. Forklift operator 1 moves forks laterally (maximum opposite lateral position from lateral movement required) and prepares for canister(s) insertion into the MILVAN. _____

DANGER

Do not stand under or in path of raised load; serious injury or death may result if struck by moving load.

4. Lower canister(s):

- a. Signal forklift operator 1 to lower canister(s) to approximately 6 inches. _____
- b. Forklift operator lowers canisters to approximately 6 inches. _____

Note: Align canister(s) properly between MILVAN side walls and the MILVAN 2x4 floor center alignment lumber.

5. Insert canister(s):

- a. Signal forklift operator 1 to laterally insert canister(s) approximately 8 inches into the MILVAN. _____
- b. Forklift operator 1 laterally inserts canister(s) approximately 8 inches into the MILVAN. _____

DANGER

Use extreme care when placing the 4x4 lumber beneath raised canisters. Falling canisters may result in loss of limb or death.

6. Position 4x4 lumber: Position the 4x4 pieces of lumber 4 feet in length beneath the forward and rear end of the isolation frames. _____

DANGER

Firmly seat canister(s) on 4x4 lumber to prevent canister(s) from tipping, which may result in injury or death.

Do not stand under or in path of raised load; serious injury or death may result if struck by moving load.

7. Lower canister(s):

a. Signal forklift operator 1 to lower canister(s).
 Ensure canister(s) is firmly seated on the 4x4 lumber and the floor of the MILVAN.

b. Forklift operator 1 lowers canister(s).

DANGER

Do not leave forklift unattended without chocking wheels. Forklift may roll, resulting in injury or death.

8. Release canister(s):

a. Signal forklift operator 1 to slowly disengage from canister(s).

b. Ground-guide forklift operator 1 to a safe distance away from canister(s).

c. Forklift 2 slowly disengages from canister(s) and backs away to a safe distance.

WARNING

Keep hands and feet away from forklift forks to prevent injury.

Observe operations for safety hazards.

9. Position forklift 2 for canister "push:"

a. Signal forklift operator 2 to position forklift forks "push" assembly beneath the lower rear end of isolation frames.

b. Have a crew member assist in guiding the forklift tines (forks) "push" assembly under the lower rear end of the isolation frames.

- c. Forklift operator 2 moves forklift forks with “push” assembly under the lower rear end of isolation frames. _____

Note: Use of chains to restrain lateral movement of missile canister(s) (while on tines) is strongly recommended throughout the entire operation.

- 10. Connect forklift chain to canister(s); hook chains from forklift through lower rear end of isolation frames to prevent lateral movement of the canister(s). _____

Note: Align canister(s) properly between MILVAN side walls and the MILVAN 2x4 floor center alignment lumber.

DANGER

Do not stand under or in path of raised load; serious injury or death may result if struck by moving load.

- 11. Raise canister(s):
 - a. Signal forklift operator 2 to raise canister(s) end approximately 6 inches. _____
 - b. Forklift operator 2 raises canister(s) approximately 6 inches. _____
 - c. Have a crew member remove the 4x4 lumbers from forklift “push” path. _____

- 12. Push canister(s):
 - a. Signal forklift operator 2 to slowly push canister(s) completely inside of the MILVAN. _____
 - b. Ground-guide forklift operator forward. _____
 - c. Forklift operator 2 pushes canister(s) completely inside of the MILVAN. _____

- 13. Lower canister(s) and release chain tension:
 - a. Signal forklift operator 2 to lower canister(s) onto MILVAN floor and slowly move forward to release chain tension. _____
 - b. Forklift operator 2 lowers canister(s) onto the MILVAN floor and slowly moves forward to release chain tension. _____

14. Disengage forklift 2 from canister(s):

- a. Have a crew member assist disconnecting chains from lower rear end of isolation frame. _____

Note: Properly fit missile canister(s) by pushing bottom isolation frames with forklift forks.

- b. Signal forklift operator 2 to push bottom isolation frames as needed to ensure proper fit in MILVAN. _____

- c. Signal forklift operator 2 to slowly disengage from canister(s) and back away slowly to a safe distance from the MILVAN. _____

- d. Ground-guide forklift operator 2 to a safe distance away from the MILVAN. _____

- e. Forklift operator 2 slowly disengages from canister(s) and slowly backs away to a safe distance from the MILVAN. _____

Notes:

- Add center dunnage prior to the addition of the second stack of canisters.
- Use previously stored blocking material for load procedure.

15. Repeat steps 2 through 14 for additional load of MILVAN. _____

16. Perform after-operation PMCS on 10,000-pound forklift(s). _____

APPENDIX B

PATRIOT BATTALION EQUIPMENT AND ORGANIZATION

This appendix provides a physical description of Patriot equipment and support equipment organic to the battalion.

Patriot is an AD guided missile system designed to cope with the AD threat beyond the year 2000. The threat characteristically employs defense suppression tactics using TBMs, saturation, maneuver, and electronic countermeasures (ECM). Patriot is effective against aircraft at all altitudes and against several types of TBMs using automated operations with capability for human intervention.

SYSTEM FEATURES

The single, multifunction phased-array radar performs the following functions that required separate radars in older systems:

- High- and low-altitude surveillance.
- Target detection.
- Identification.
- Target tracking.
- Missile tracking.
- Missile guidance.

The missile is command-guided by the radar to a point just prior to intercept. At this point, the unique track-via-missile (TVM) guidance mode begins. The radar set (RS) sends out a special waveform that illuminates the target and sends an uplink message that commands the missile to open its receiver for detection of reflected TVM waveform energy from the target. The missile encodes and sends

boresight errors via downlink messages back to the radar. Guidance computations are then made by the engagement control station (ECS) and are sent back through the radar to the missile, via uplink messages. This process continues until intercept, providing a greater accuracy than other types of guidance systems.

The automated operation provides firepower at saturation levels many times greater than earlier systems, in addition to a multiple simultaneous engagement capability. Built-in test equipment (BITE) and automated diagnostics, along with fewer system-peculiar major items, provide a significant improvement in availability and maintainability. Figure B-1 on page B-2 portrays the scheme of operations of a Patriot battalion and provides the principal functions of each major item.

PATRIOT SYSTEM OPERATIONAL OVERVIEW

The Patriot system has four major operational functions.

- Communications.
- Command and control.
- Radar surveillance.
- Missile guidance.

The four functions combine to provide a coordinated, secure, integrated, battalion-level,

and mobile AD system. The Patriot system is capable of defending assets and areas in support of Army field forces against multiple hostile TBMs and aircraft in an ECM environment (jamming and deception). Figure B-2 on page B-3 shows the operational interfaces within the Patriot battalion and the external interfaces with brigade and other AD elements.

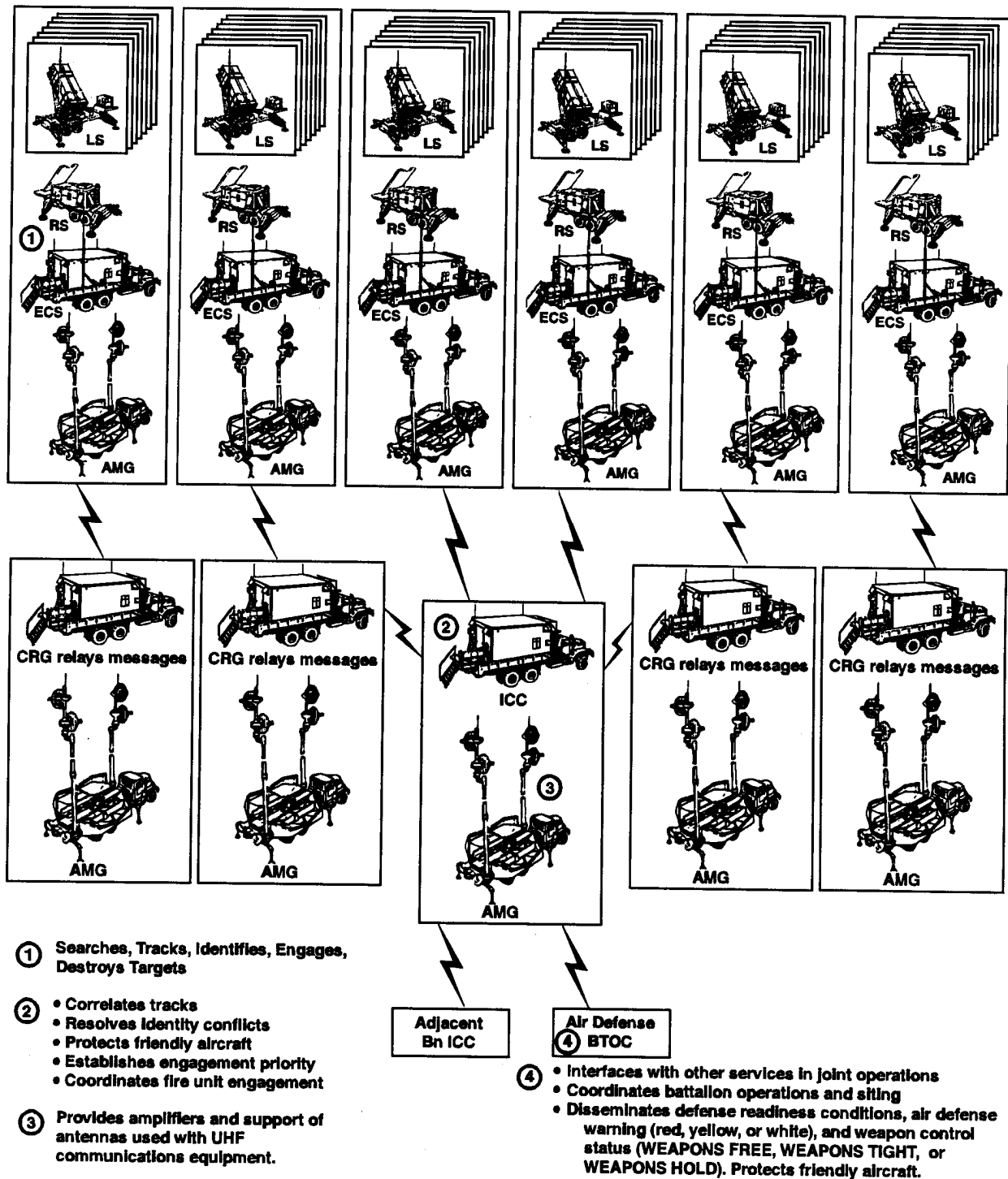

Figure B-1. Patriot operations.

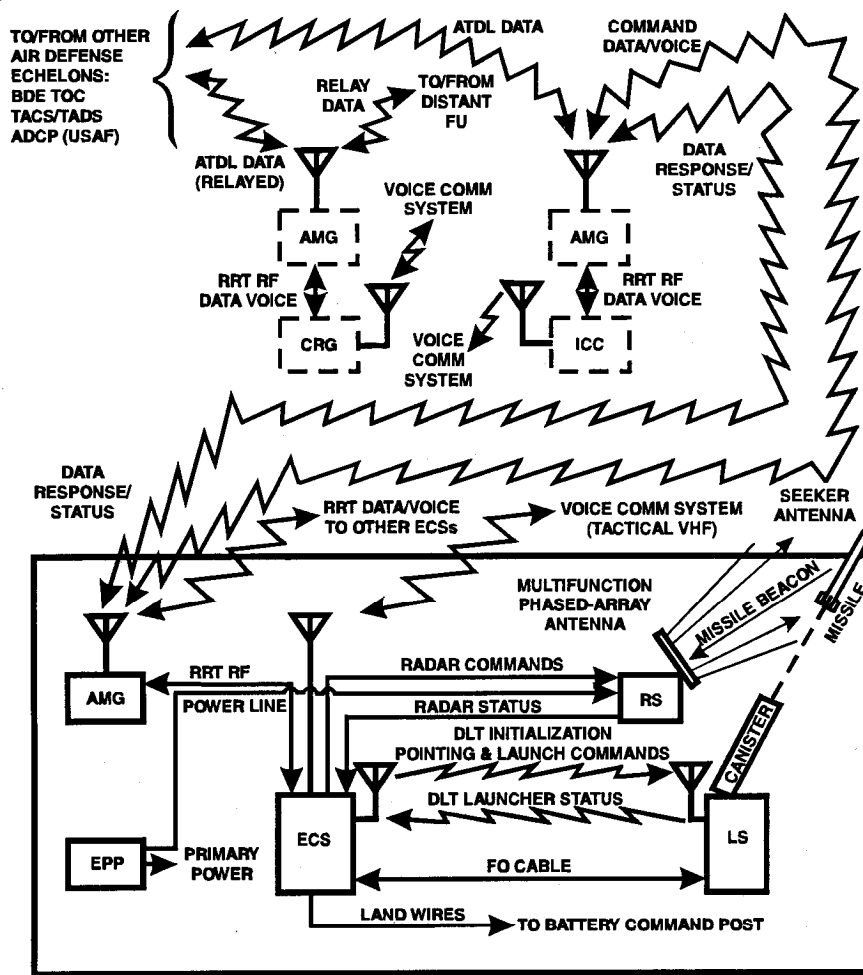

Figure B-2. Patriot system overview block diagram.

The ICC provides the Patriot system with automatic data processing (ADP) and communications capabilities required to operate with other AD systems. The ICC communicates with the BTOC using the Army tactical data link-1 (ATDL-1) and TADIL-B. The Patriot ICC may be interconnected with other weapons and surveillance systems such as USAF tactical air control and tactical air defense systems (TACS and TADS) plus USAF air defense command and Airborne Warning and Control System (AWACS). The BTOC equipment also provides a link with Hawk AD units.

Three radio systems provide the Patriot battalion and fire unit communications. The first is the direct link between battalion to brigade communications link via the multiple subscriber equipment (MSE). The second is a UHF pulse-coded modulation data or voice communications system operating through radio relay terminals (RRTs) in the ICC and ECS. An additional unit, the CRG, also contains radio relay terminals. The third is a very high frequency (VHF) voice communications system used for tactical intrabattalion communications (battery-to-battery and battery-to-battalion).

Patriot fire control communications are provided by three RRTs in each ICC and ECS, and four RRTs in each CRG. Although primarily for data transmission, the RRTs can be used for voice communications. When the terrain makes direct line-of-sight paths impossible, intermediate stations are required. At each end of a UHF data link is an antenna mast group (AMG) with four rotatable, directional parabolic antennas, on two pneumatically erected masts. Each antenna assembly includes a power amplifier for each RRT and circulator-isolators for simultaneous transmitting and receiving with one antenna. The antennas are oriented toward other AMG locations to form a UHF data link network.

DATA LINK TERMINAL

The data link terminal (DLT) is a secondary VHF link that transfers missile initiation, pointing, and launcher commands from the ECS to each launching station (LS). Launcher

PATRIOT BATTERY EQUIPMENT

The heart of the Patriot battery is the fire control section and associated launchers. The fire control section consists of an ECS, AMG, RS, EPP, and eight LSs. The primary mode of emplacement is automatic (secondary is manual, as described in FM 44-85-1 [TBP]). Once emplaced, the FU enters the initialization phase of operations. In initialization, the crew enters all data required for tactical operations into the WCC data base. This data includes masked terrain mapping of the assigned sector. Once the crew has completed initialization and entered all locally required operating data and or received transferred data from the ICC, and put all required equipment on-line, the battalion grants approval for the FU to assume tactical operations.

Upon termination of tactical operations from an occupied site, the FU can be march ordered and moved to a new presurveyed

status signals are returned to the ECS to acknowledge command receipt (primary link is fiber optics [FO]).

CENTRALIZED AND DECENTRALIZED

The Patriot system can operate as a centralized or decentralized battalion command system. FUs can operate autonomously if the tactical situation or communications failure make it necessary. Target evaluation, threat ordering, and engagement decision and weapon assignment (EDWA) is performed through the ICC and ECS man-machine interface. Evaluation and engagement decisions can be semiautomatic via operator response to console displays and indicators in the ICC and ECS, or automatic with the operator retaining override capability over the weapons control computer (WCC).

tactical site. The FU can accomplish several such moves and tactical emplacements in 24 hours.

ENGAGEMENT CONTROL STATION

The ECS is the only manned station in the FU (see Figure B-3) during battle engagements. The ECS controls the LSs via FO cable, with VHF radio data link as a backup. Data cables connect the RS and AMG with the ECS. The AMG provides the communications link with adjacent fire units and the battalion ICC.

The ECS is the operational control center of the Patriot FU. It contains the WCC, man-machine interface, and various data and communications terminals.

The ECS is air-conditioned and includes a positive pressure air filtration device and a

modular-collective protective entrance (MCPE) forced-air entry lock for use in an NBC environment. Additionally, the ECS is equipped with devices which afford the shelter electromagnetic pulse (EMP) protection in a nuclear environment.

External characteristics of the ECS include radio frequency (RF) communications antennas, air entry and exhaust ducts, a crew doorway, front-end air conditioners, radar control and prime-power cable entry ports, and a gas particulate filter unit (GPFU). The walls and inlets include electromagnetic shielding.

The curbside of the ECS contains a VHF digital data link (DDL) antenna carried

horizontally during road march. During emplacement, the crew assembles the antenna and raises it to a vertical position. This provides secondary radio communications with the LSs.

A ladder and rear entry door provide access to the shelter. Four air inlets and two exhaust fan assemblies on the forward end, and two air inlets and two exhaust fan assemblies aft near the doorway of the shelter (see Figure B-4) provide cooling air for the equipment, except UHF radio stacks which are cooled by outside air.

Terminal boxes on the forward exterior wall of the shelter provide interconnection

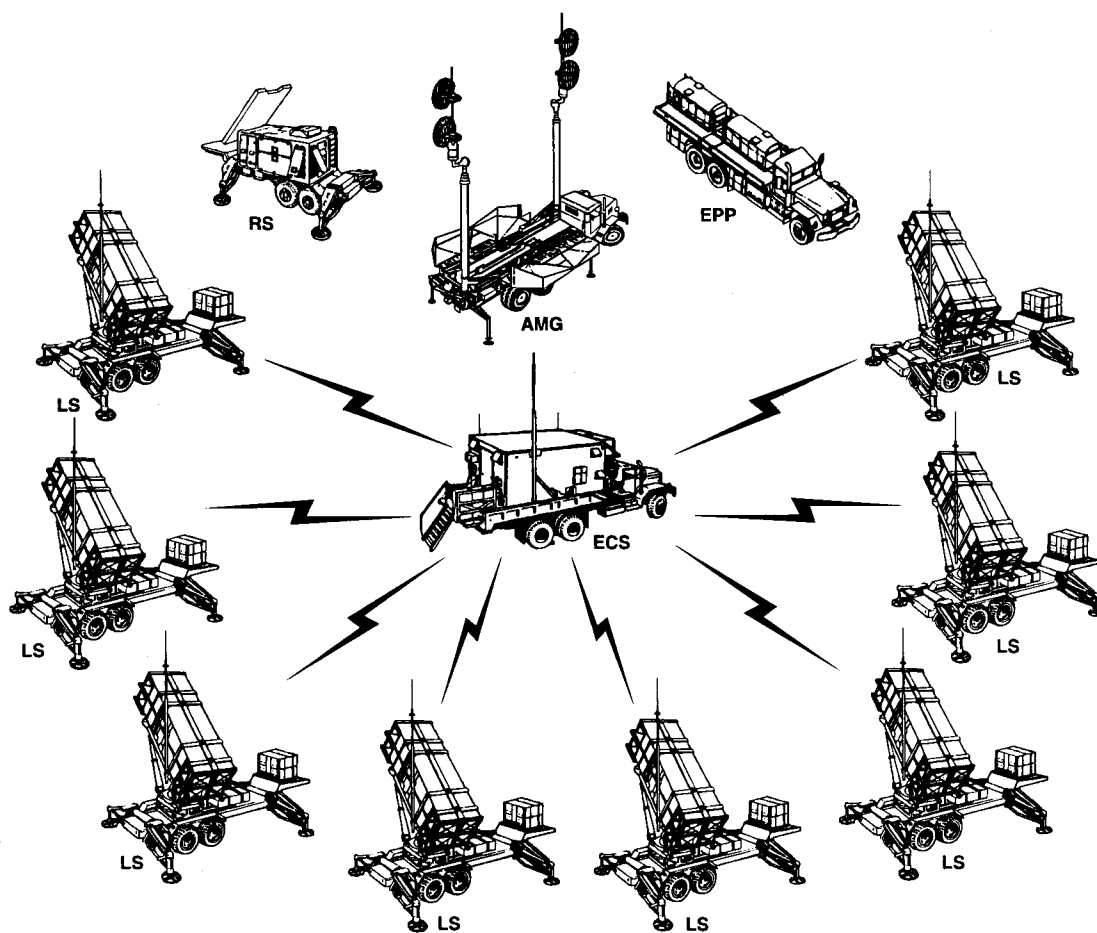

Figure B-3. Patriot fire unit.

points for power and control cables to the EPP and a single data cable to the radar. Cables to the AMG exit via connectors on the aft road-side.

The air-conditioning system which cools, heats, and ventilates the interior of the ECS includes two air conditioners which recirculate inside shelter air mixed with external air.

In NBC situations, where outside air is contaminated, the ventilating air for the ECS is drawn through a GPFU housed below the air conditioners. Particulate filters and blowers have sufficient capacity to provide a purified forced-air supply for an air-shower in the shelter entry lock. In the NBC environment, the MCPE provides a cleaning area for personnel about to enter the ECS. Note: Outside air is used to cool the UHF radio stacks, therefore, under NBC conditions, the doors to the stacks should remain closed. If they must be opened

in an NBC environment, the van should be considered contaminated and all necessary measures taken.

ENGAGEMENT CONTROL STATION SHELTER

The ECS shelter is a radio frequency interference (RFI) and weather-tight enclosure with appropriate air inlet and exhaust ports for the environmental control systems. The shelter is of standard type construction with equipment mounted at the forward end and on both sides of the center aisle.

Interior of the ECS

The interior of the ECS is shown in Figure B-5. At the forward end are two operator stations, a BITE status panel, FU status panel, an environmental control panel (air conditioner controls, ambient

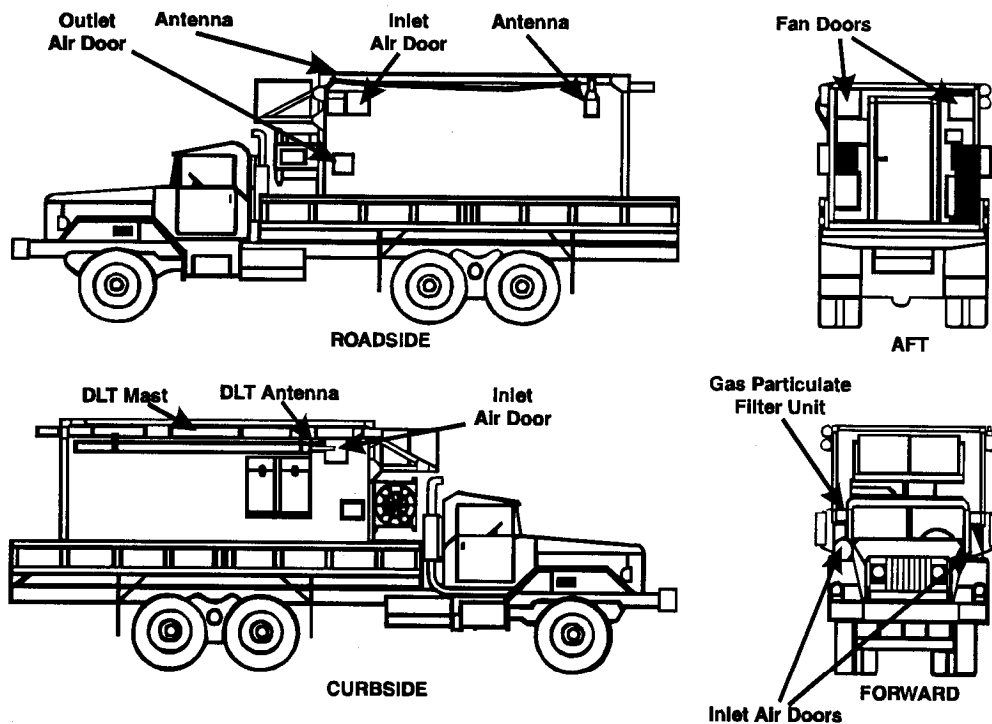

Figure B-4. External view of the ECS (less MCPE).

air controls, and lighting controls), generator control panel, hard copy unit (HCU), and power distribution unit (PDU). The left side as seen from the doorway (roadside) includes three UHF RRTs and a voice communications station (MS2). The right side (curbside) includes the VHF data link terminal, radar weapon control interface unit (RWCIU), WCC, and auxiliary communications equipment.

The Computer

The computer within the Patriot system (see Figure B-6, next page) is a 24-bit parallel militarized computer with fixed and floating point

capability. The WCC is organized in a multi-processor configuration which operates at a maximum clock rate of 6 megahertz.

Weapons control computer. The WCC provides the necessary data processing for the Patriot FU, including capability for communications with other FUs or battalions through a routing logic radio interface unit (RLRIU).

The major subsystems within the computer system are the—

- Central processing unit (CPU).
- Input/output control unit (IOCU).
- Monolithic memory unit (MMU).
- Peripheral control unit (PCU).

The WCC configuration consists of two CPUs, one IOCU, and 512K of main memory.

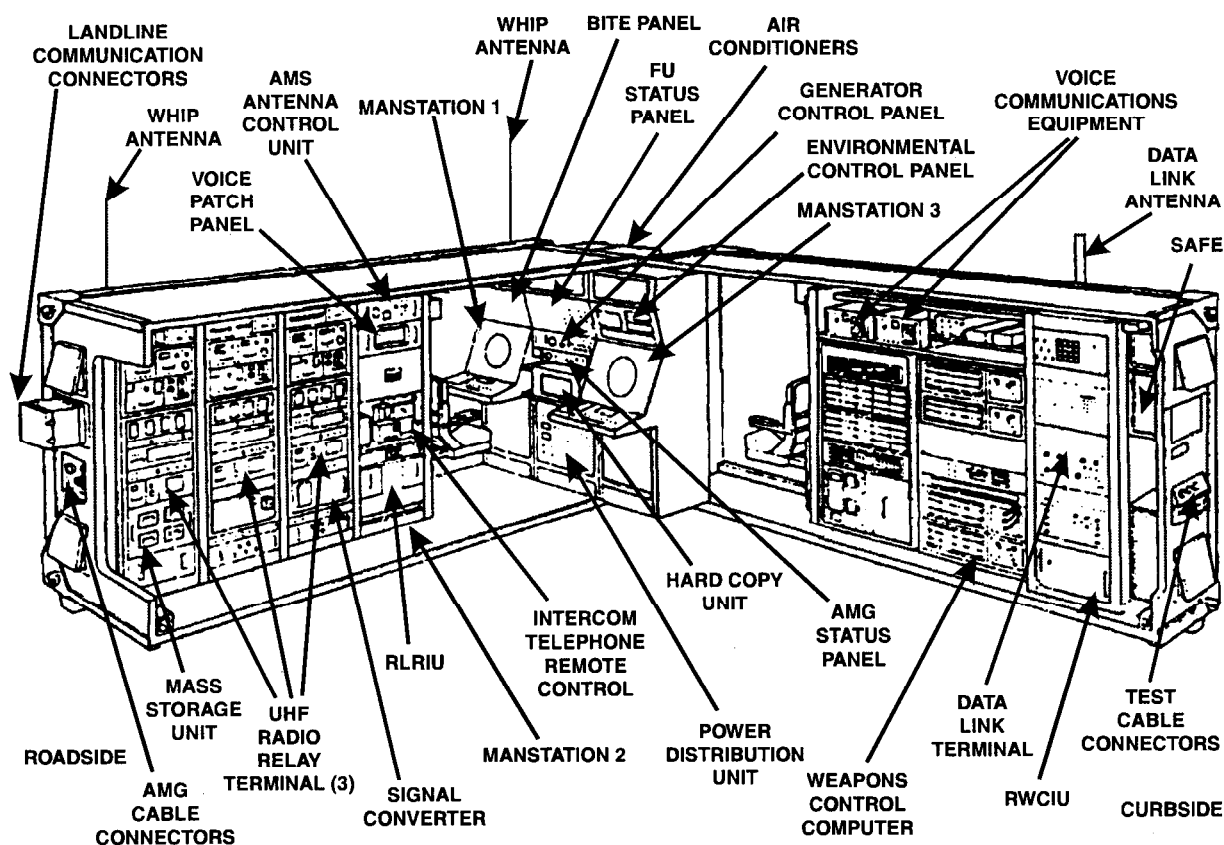

Figure B-5. Cutaway view of the ECS.

Central processing unit. The WCC CPU exhibits a broad variety of instructions and addressing modes as well as processing power. Each CPU has a maximum computational capability of one million ads per second (MAPS), permitting a dual central processing unit multiprocessor configuration to exhibit a two-MAPS capability.

Input/output control unit. The IOCU controls and communicates with all external interfacing subsystems. All data in the memory is accessible by the IOCU at a one word per microsecond rate.

Monolithic memory unit. The building blocks of the WCC memory system are two monolithic memory drawers which contain plug-in medium scale integration modules. Memory blocks of 32K may be added or removed from each drawer. Maximum

memory storage is eight blocks of 32K per drawer (256K) or 512K per system.

Peripheral control unit. The PCU is used to interconnect the hard copy unit (HCU), the recovery storage unit (RSU), the mass storage unit (MSU), and the computer maintenance panel (CMP) with the computer.

Weapons control computer peripherals. The WCC peripherals which are controlled by the PCU consist of the following:

Hard copy unit. The HCU provides printouts of selected tabular displays, fault detection and assessment data, and communications messages received by the FU. Printout is initiated by the operator pressing the hardcopy key on the keyboard.

Recovery storage unit. The RSU is a high-speed dual tape drive used for loading computer programs into the WCC memory. Initialization

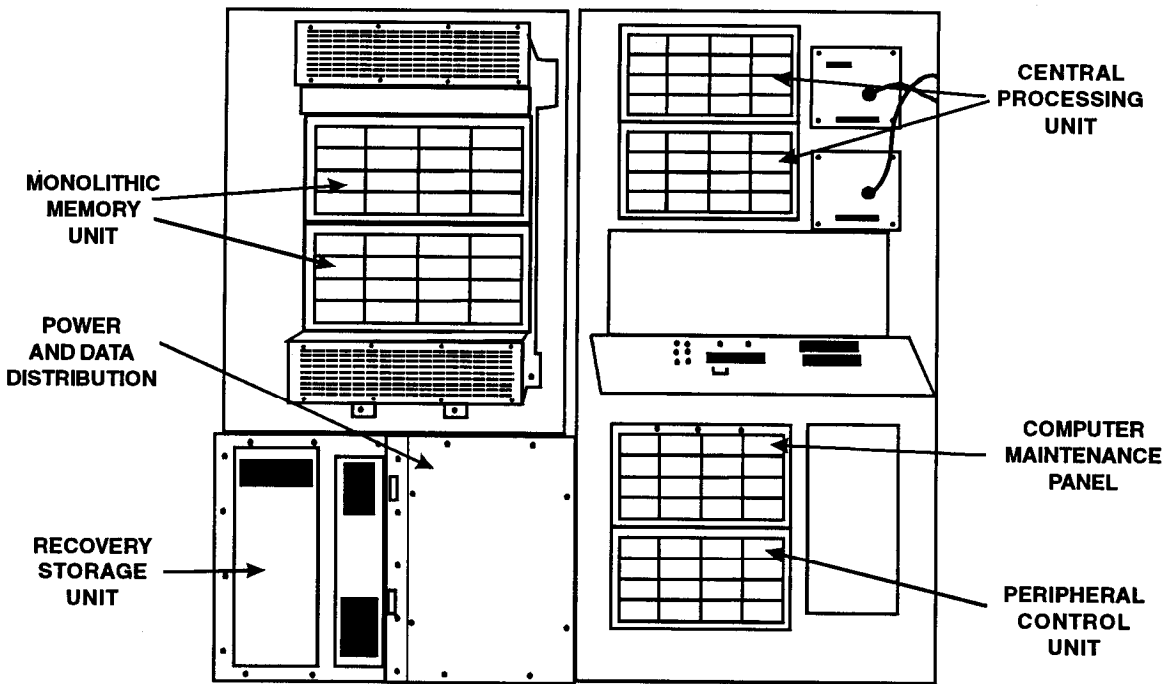

Figure B-6. Weapons control computer.

programs, operating programs, diagnostic programs, and data may be loaded via tape cassettes. The RSU is also used to restore the complete contents of the computer memory in case of EMP or other electromagnetic transient which may garble or erase any portion of that content. Following initialization, the tape in the RSU will contain a duplicate set of the program and particular site data as stored in the computer memory.

Mass storage unit. Four tape transporters and associated interface electronics comprise an MSU. The MSU is used for loading computer programs into the WCC memory and is also used to store the operational maintenance procedures and the troop proficiency trainer (TPT) scenarios.

Computer maintenance panel. The CMP is used for manual testing of the WCC. The switches on this panel setup, select, and control computer tests. Panel indicators show data register contents. The computer maintenance panel indicators also monitor WCC power supply, data parity, and clock functions.

COMPUTER PROGRAMS

A number of WCC programs direct the operation of the Patriot FU equipment. The following paragraphs group the programs according to functions.

System Initialization

This group of programs performs the functions of loading all necessary data into the WCC and other special purpose computers in the RS, collecting and storing site-peculiar data (such as radar orientation coverage boundaries, horizon map, and masked regions), establishing equipment operability, and loading the system operational programs. The system is capable of rapid reinitialization in the event of an EMP occurrence (which could destroy data within the digital computers) or when the system has

been down for repair. The RSU provides this capability using the recovery data tape.

System Operation

System operation of WCC programs provide centralized real-time control of all elements of the fire unit. The following discrete functions are included:

- Control, action-by-action, of the RS in performance of search; target track; identification, friend or foe (IFF); missile acquisition; and track, midcourse, and terminal guidance commands.

- Selection and processing of data for display to the operators and implementation of operator inputs via the display and control subsystem.

- Selection of LS and communications to the LS of missile initial turn parameters and missile launch commands.

- Communications, via digital communications equipment, with higher echelon and adjacent Patriot elements.

- Status monitoring functions to detect failures within and determine the operational status of all elements of the FU.

These operational programs also evaluate all target track and environment data to determine which targets are hostile and threatening and in what order the system should engage them for maximum effectiveness. Results of this evaluation are presented to the operators. Depending on the mode of operation, the system will either automatically execute the engagements or wait for the operator to command engage. The operator can override any automatic engagement decision.

Diagnostics

This group of programs provides for rapid location of failed components and a check for proper operation after repair. The operator selects and loads the program based on

information obtained from the status monitoring function. The fault isolation display-aided procedures called up by the operator will display the step-by-step repair procedures to permit the operator to isolate the problem.

Training

Proficiency training is provided by a set of programs which, with associated scenario tapes, constitute the troop proficiency trainer, terrain map trainer, and on-line training mode.

DISPLAY AND CONTROL GROUP

The focal control point and nerve center for the Patriot FU is located at the display and control group in the ECS. At this position, the operators monitor plan-position indicator scopes and surrounding indicator lamps and readouts. The combined assemblage of readouts provides them with the data required to operate and control the system.

The operators can select fully automatic modes and act as FU monitors with a command option for interceding. They can also select semiautomatic modes in which they exercise preselected C² options according to the TSOP.

CONTROL INDICATOR PANEL

The control indicator panel (Figure B-7) provides the controls and displays necessary to oversee the local tactical environment and call up specific categories and classes of information. Typical display data include zones of coverage, friendly and hostile targets, and electronic counter-countermeasures (ECCM).

Situation Display Presentation

A situation display presentation can be overlaid with diverse types of symbols, boundary lines, grids, and alphanumeric statements and tables. It can be enlarged or reduced, lined into zones, segmented into

coverage areas, overlaid with chosen categories of symbols and tracks, and configured with computer commentaries and or listings of data.

Controls and Displays

Push buttons, shown in Figure B-7, provide the operator with the means to control the fire unit.

Console mode. The following four push buttons select the operational mode for the console:

- Weapon control.
- Friendly protection.
- Equipment control.
- ECCM assistance.

Situation display select. The following eight map data options are available for zones and geographic data to be painted on the display scope:

- Defended areas.
- Weapon control areas.
- Geographic reference grids.
- Masked terrain.
- Sector boundaries.
- ID areas.
- Range rings.
- Launcher graphic display.

Track data. The following-thirteen options are available to call up particular categories of display information:

- Altitude A selection of track data.
- Altitude B selection of track data.
- Altitude C selection of track data.
- Altitude D selection of track data.
- Friendly aircraft.
- Unknown aircraft.
- Hostile aircraft.
- ECM strobes.
- Launch now intercept points.
- Predicted intercept points.
- Track numbers.
- Track data (altitude and threat level).
- Passive search.

Offset/Scale. The following five options are available to offset and or magnify the scope

•• SALVO (shoot two as quickly as possible).

Low power. This push button reduces transmitter radiated power.

Engagement override. This push button provides the following three options to inhibiting engagement of individual targets:

- HOLD FIRE (includes destruct command to any missile in flight to the target).
- CEASE FIRE (no destruct command to airborne missiles).
- ENGAGE HOLD (no automatic launches permitted against the target).

Radiate. This switch/indicator (WI) ceases or resumes radar radiation.

Track evaluate. For individual targets, the operator can—

- Designate an individual target identity.
- Initiate identification, friend or foe interrogation.
- Display tabular data file on target.
- Display flight path history.
- Drop track.

System control. Functional push buttons allow the operator to select the FU method of control and weapon control status (WCS) as follows:

- Decentralized control with digital data link communications to the ICC.
- Independent FU operation, with voice communications to higher authority.
- Autonomous operation with no communications to higher authority.
- WEAPONS HOLD (fire only in self-defense or in response to a formal order).
- WEAPONS TIGHT (fire only at targets identified as hostile).
- WEAPONS FREE (fire at any target not positively identified as friend).
- Select initialized weapon control volumes.
- Operate in severe weather conditions.

Radar, IFF, and launcher control. Radar, IFF, and launcher control push buttons, divided into four categories, allow the

operator to—

- Reduce or shape the FU coverage zone.
- Enable, disable, or vary parameter for identification, friend or foe.
- Place launchers in the operate or standby state.
- Enable or disable use of the active ECCM modes.

CONTROL KEYBOARD ASSEMBLY

The control keyboard assembly provides an alphanumeric keyboard and accessory controls for communications with the WCC. The assembly, which is positioned at table top height in front of the operator, provides controls and options (Figure B-8).

• A—An isometric stick is used to position a situation display cursor to mark the coordinates of a position. The cursor coordinates are used by the hook function and the offset function.

• B—The hook key selects, for a subsequent action, a target within a defined distance from the coordinates of the cursor on the situation display.

• C—The operator uses the keyboard to initialize the computer with particular Patriot FU parameters. Data inputs for the computer include items such as geographic location and altitudes, surveillance areas, priorities, engagement doctrines, and launch zones. The keyboard also functions as a general purpose access point for computer diagnostics and operator requests for data, including hard copy.

• D—The communications panel located at the left end of the keyboard enables the operator to connect battery terminal equipment with that of any remote station in the network. A unique audible coding system means stations not called will not be disturbed by having to monitor unwanted messages.

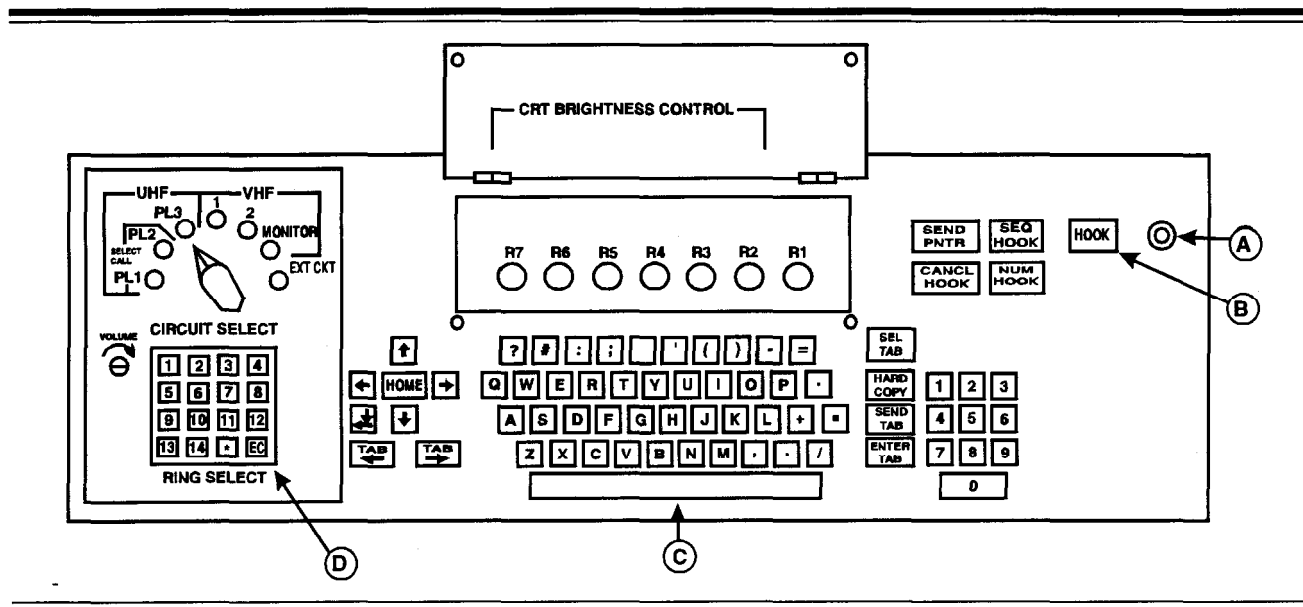

Figure B-8. ECS control keyboard assembly.

STATUS PANEL

The status panel (Figure B-9, next page) is located above and between the two fire control operator consoles. This panel provides color-coded indicator lamps and numerical readouts indicating the C² status and the GO/NO-GO conditions of FU equipment, communications links, and the LSs.

Indicator lamps and readouts labeled A to H provide the following:

- A—TIME OF DAY. This indicator provides a digital readout of the time of day (hours, minutes, and seconds).
- B—FP (FIRING PLATOON). FU control status readouts consist of color-coded lamps and alphanumeric as follows:
 - DEFCON—Numerals 1 through 5 indicate the state of EMCON.
 - ALERT STATE—Seven possible FU alert states are indicated by the numbers 1 to 7 overlaid with the colors yellow or green. Yellow indicates that the FU is working toward achieving the numbered state. Green indicates the state has been attained.

- METHOD CONTROL—Indicates whether the FU is under centralized, decentralized, or autonomous control.
- WEAPON CONTROL—Indicates the weapon control status: WEAPONS FREE, WEAPONS TIGHT, or WEAPONS HOLD.
 - C—ATTACK WARNINGS. The following lamps indicate the attack alarm state passed down from higher echelons:
 - ADW—Color indicates the ADW alarm state: red, yellow, or white.
 - MSL ATTK—Illuminates red to indicate a tactical ballistic missile attack warning.
 - CBR—Illuminates red to indicate a chemical or biological attack warning.
 - D—EQUIP. This lamp illuminates to indicate status of fire control equipment.
 - Green—All elements of the fire control section equipment are on-line and operational (GO).
 - Yellow—One (or more) element of the fire control section is in a degraded state.

- Red—Some required item of fire control section equipment is inoperative.
- E—COMMO. This lamp illuminates to indicate the status of the FU data communications equipment as follows:
 - Green—fully operational.
 - Yellow—degraded.
 - Red—inoperative.
- F—MSL INVENTORY. This displays the total number of ready missiles in the FU.
- G—Missile inventory counters indicate the number of ready missiles available at each of the eight LSs.
- H—The following launcher status lamps illuminate to indicate the status of each LS:
 - OPER/STBY indicates whether the LS is in the operate or standby mode.
 - OPER lamps illuminate to indicate the operational status of the LS: green—fully operational, yellow—degraded, and red—inoperative.
 - FUEL lamps illuminate to indicate the fuel supply for the LS generator: green—adequate fuel or yellow—fuel is low.

- DDL lamps illuminate to indicate the status of the LS/ECS digital data link: green—fully operational, yellow—degraded, or red—inoperative.

BUILT-IN TEST EQUIPMENT PANEL

The built-in test equipment (BITE) panel is a multiple-purpose display unit located above the left console. The display panel switches and indicators are labeled A through G in Figure B-10.

- A—The EXT ALERT push button enables the sounding of an audible external alarm indicating the unit is preparing to radiate or rotate the radar.
- B—The D&C STATUS lamps display failure locations for D&C subassemblies.
- C—The COMPUTER STATUS lamps display failure locations for WCC subassemblies.
- D—The PROG HALT switch when depressed causes a program interrupt.

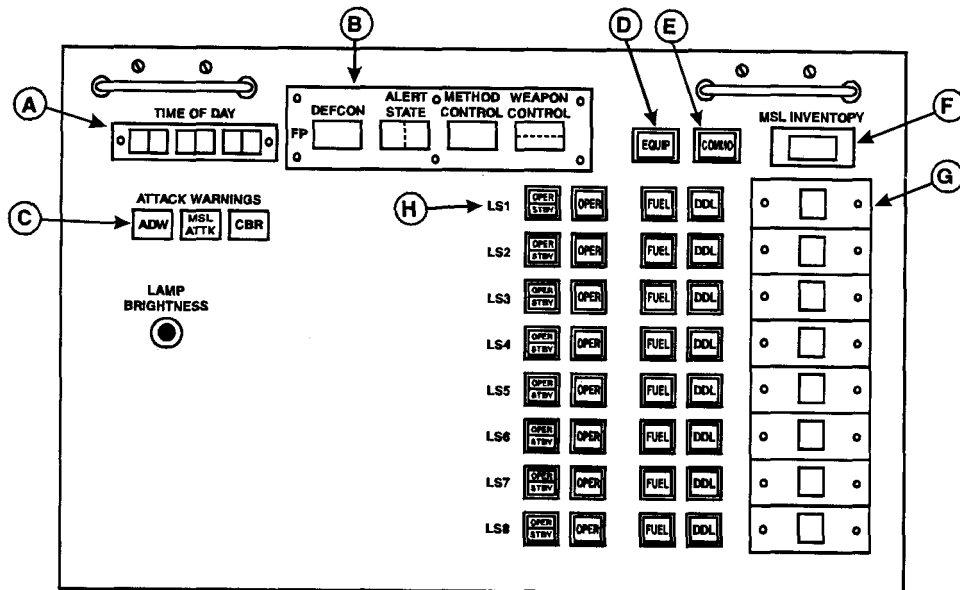

Figure B-9. ECS status panel.

- E—The BOOTSTRAP INIT push button initiates the bootstrap program used to start the loading of the computer program.
- F—The COMP & SYS RESET push button clears the WCC.
- G—The COMPUTER CONTROL LOAD DEVICE SELECT control switch determines whether the WCC is to be loaded via—
 - The RSU.
 - MSU (1 or 2) for diagnostics and other support programs.
 - Nontactical peripherals.

RADAR WEAPONS CONTROL INTERFACE UNIT

Digital data link communications between the ECS and the radar are carried on a single multiconductor cable interfaced at both ends with an RWCIU. At the ECS end of the cable,

the RWCIU accepts a 32-bit operational code and status words from the WCC and translates them to serial format. The individual bits are then sent to the radar. The unit demodulates and translates incoming signals for interface with the WCC.

At the radar end of the cable, an RWCIU receiver decodes the WCC messages for use in timing, code selection, transmitter control, beam pointing, switching, and mode control of the receiver ground processor. Messages returned from the radar provide all necessary data for display and WCC processing.

UHF TRANSMITTER-RECEIVER TERMINALS

These are the “UHF stacks” found inside the ICC, ECS, and CRG shelters. Each of these shelters has the same RRT stacks.

Each RRT consists of an AN/GRC-103 radio, a KG-194A security device, a

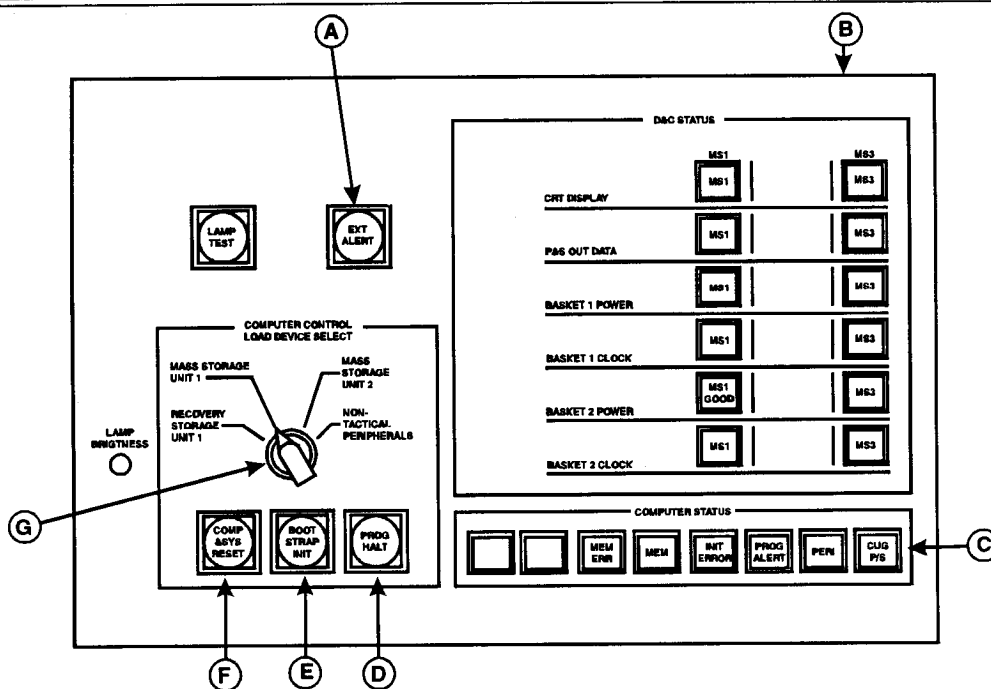

Figure B-10. BITE panel.

multiplexer TD-660, and a high-speed serial data buffer TD- 1065. All of these items, together with one AMG antenna (or shelter corner reflector antenna) form one terminal of a UHF line-of-sight microwave radio link providing 12 communications channels. The circuits are routed through the communications patching panel for convenience in cabling. One channel of each UHF radio is dedicated for data. The remaining 11 channels of each RRT can be interconnected or connected to the modems (ICC and CRG), to the party-line hybrids, or to the external lines by means of patch cords.

DATA LINK TERMINAL

The data link terminal (DLT) is shown in Figure B-11. The equipment incorporates

several communications security (COMSEC) and ECCM features for secure communications exchanges with the LS.

The single-channel ground and airborne radio system (SINCGARS) is a family of standard military VHF-FM, voice, and digital data communications systems. COMSEC is accomplished by means of a TSEC/KY-57. Modes of operation include single channel (SC) and frequency hopping (FH) in either voice or digital data. The AN/VRC-90 provides the VHF radio data link between the ECS and LS and is the primary backup to the FO cable.

The processor feeds data to and from the FO interfaces or the AN/VRC-90 under control of the WCC and the RLRIU. The slave bus unit (SBU) provides the interface between the processor and master bus unit

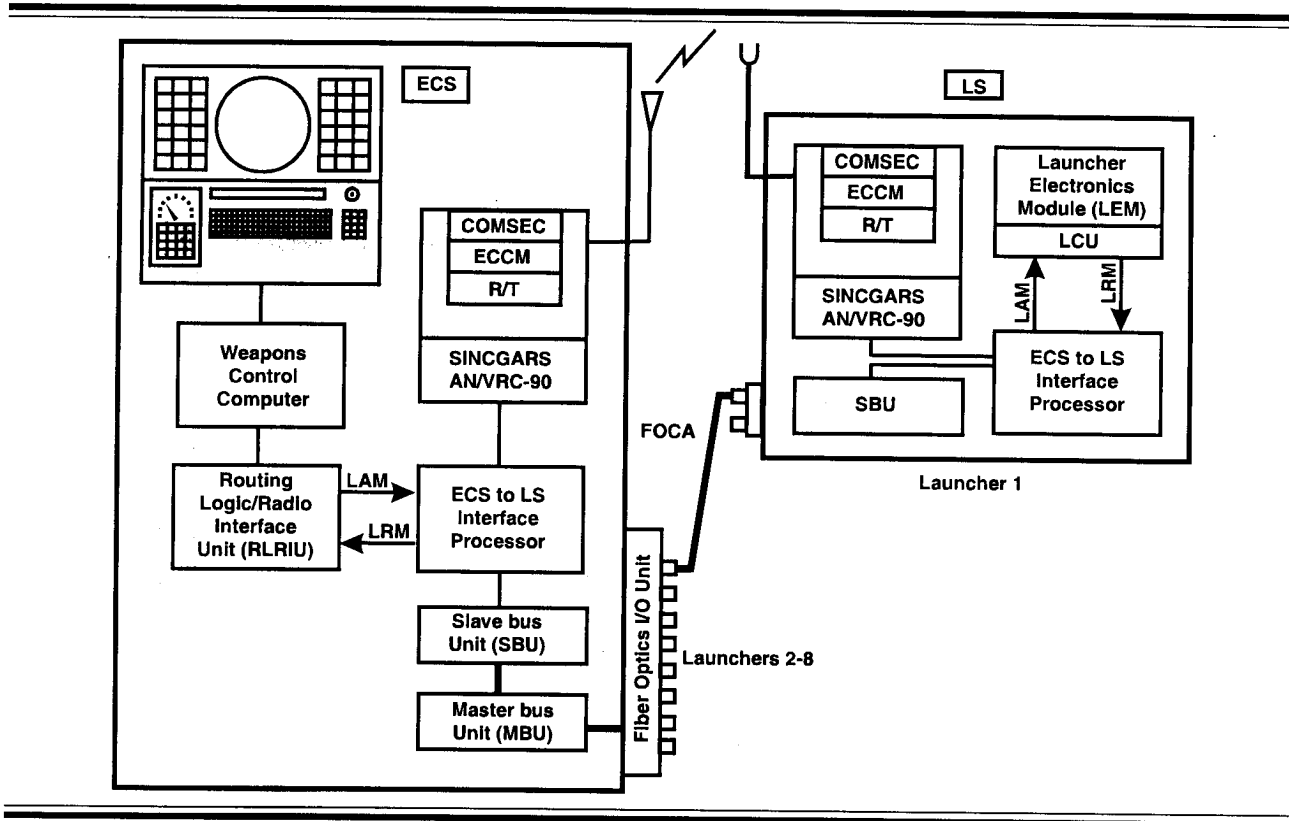

Figure B-11. Patriot ECS-LS data link terminal (DLT).

(MBU) in the ECS, and the processor and FO interface unit in the LS.

The MBU provides control and timing for the ECS SBU and develops the output power required for transmission to all LSs through the FO cable. The MBU can be

operated as an SBU when two or more MBUs are in a net.

VOICE COMMUNICATIONS

The ECS voice communications system (see Figure B-12) consists of two VHF

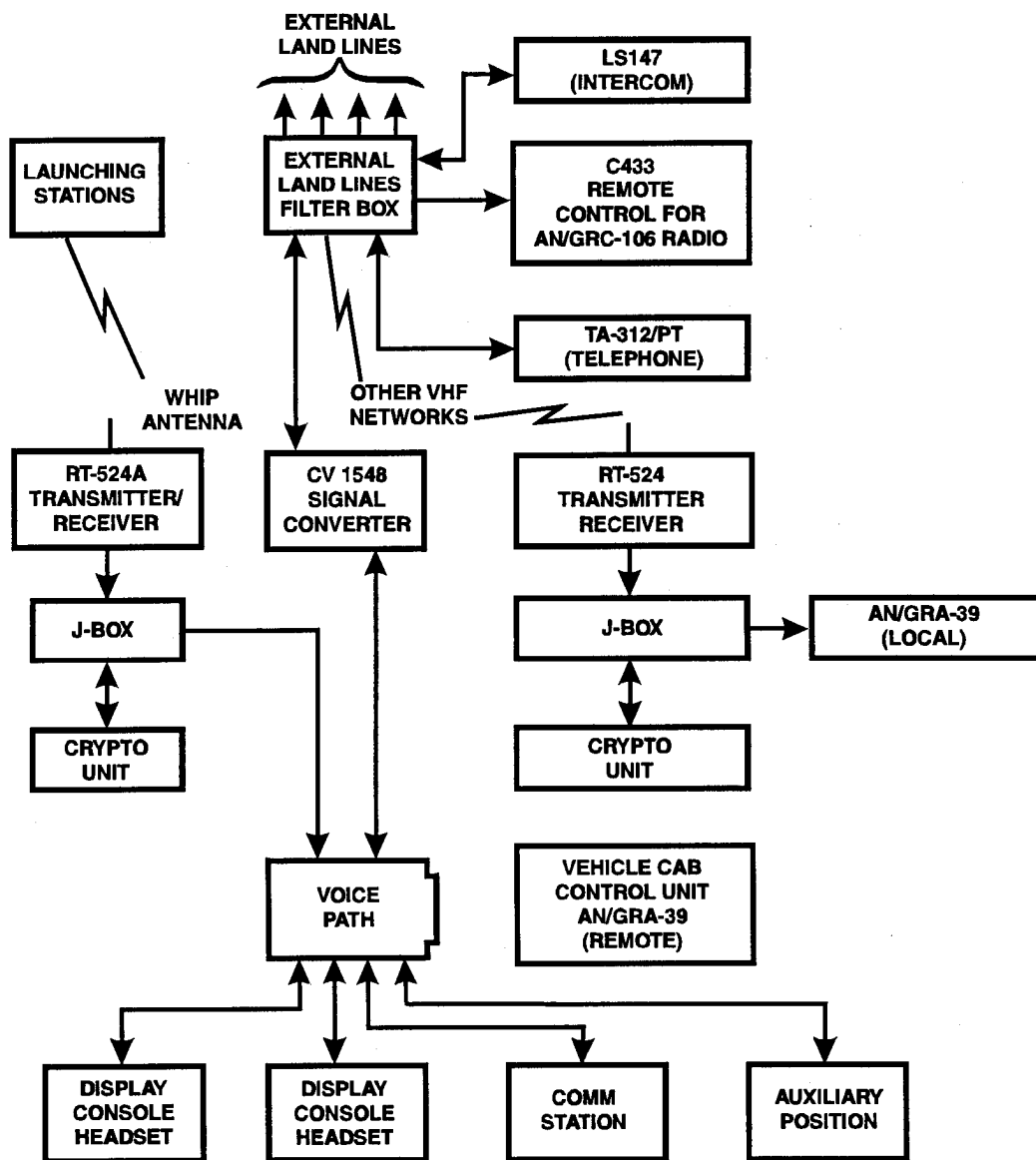

Figure B-12. Voice communications (ECS).

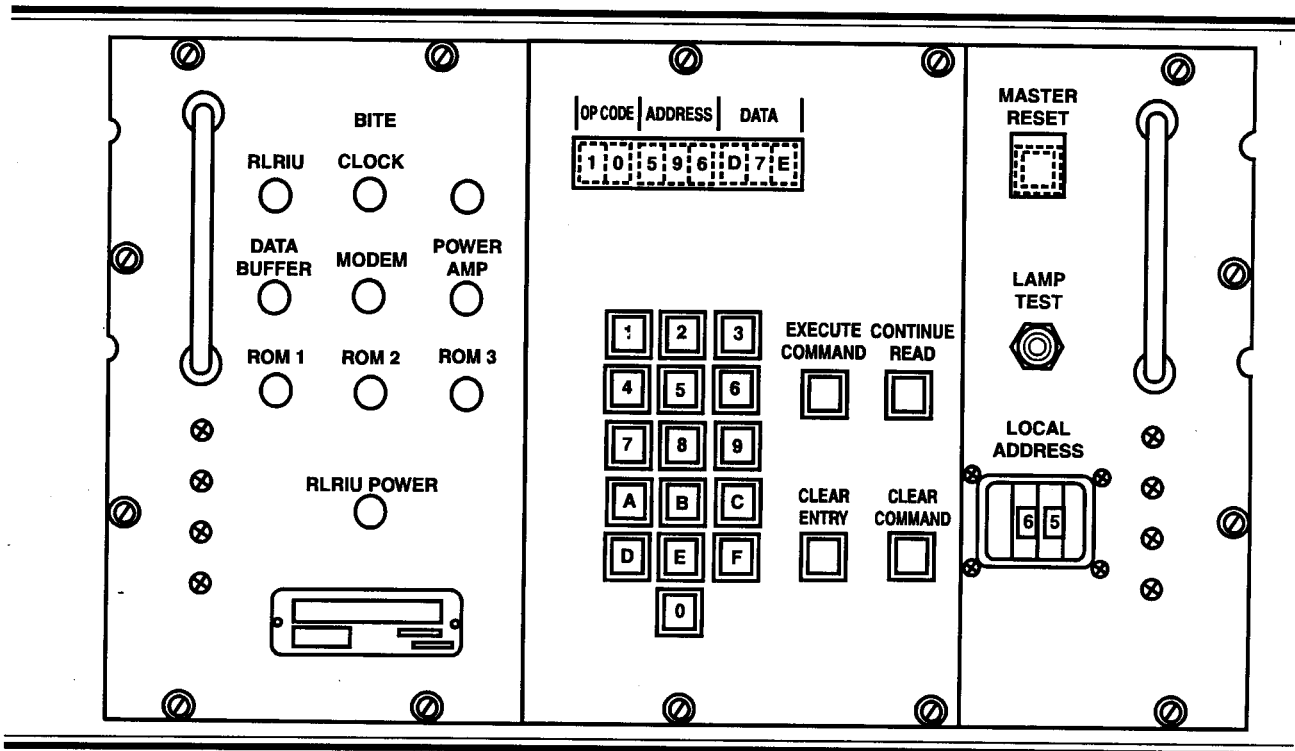

Figure B-13. RLRIU.

transmitter-receivers and encrypting devices. The ECS can conduct secure voice communications with the FU voice net and the command net and can monitor the administrative net. Interconnections with the radio link are made by means of operator control units located at the—

- Display console (two).
- Communications station (one).
- Auxiliary position (one).

The communications patching panel is located on the forward interior roadside of ECS, ICC, and CRG shelters.

ROUTING LOGIC RADIO INTERFACE UNIT

The RLRIU (Figure B-13) provides the interface between the computer and the DLT, the computer and the UHF terminals, and between the UHF terminals.

The functions provided by the RLRIU at

the ECS include message buffering, message validation, message packet processing, bit timing, built-in test, message accounting for multiple routing, UHF link error monitoring, Patriot AD information language transmission formatting, and housekeeping functions.

WIRE COMMUNICATIONS

The ECS, ICC, and CRG have external land line connections. Land lines will allow the following capabilities:

- Voice intercom between various facilities which may be collocated with ECS or ICC (communications center, commander, executive officer, and battalion maintenance officer).
- Control of AN/GRC-106 shortwave transceivers to remote locations.
- Field telephones to an outside location.
- Four- and two-wire circuits from the communications patching panel inside the

ECS to an outside facility. These circuits may be used for voice (for example, to an external SB-22 or SB-3614, four-wire switchboard).

- These external land lines are filtered and provided with transient suppressors to protect the equipment interface to the ECS.

ENVIRONMENTAL CONTROL

The ECS shelter is divided into a sealed electronics equipment area and an operator compartment.

The air conditioners cool the operator compartment in hot weather and warm it in

winter. The environmental control panel (Figure B-14) for the air conditioners and the ambient air cooling system status panel for the equipment cooling outside air fans are located above the curbside operator.

The ECS is equipped with an alarm to alert the operators when pressure has been lost and NBC masking is required. The unit feeds filtered outside makeup air into the air conditioner ventilation system.

In contaminated, or potentially contaminated environments, the GPFU unit provides a purified air flow to an air shower in a sealed air lock modular collective protection equipment mounted and sealed over the ECS entry door. The crew entering the MCPE shelter will

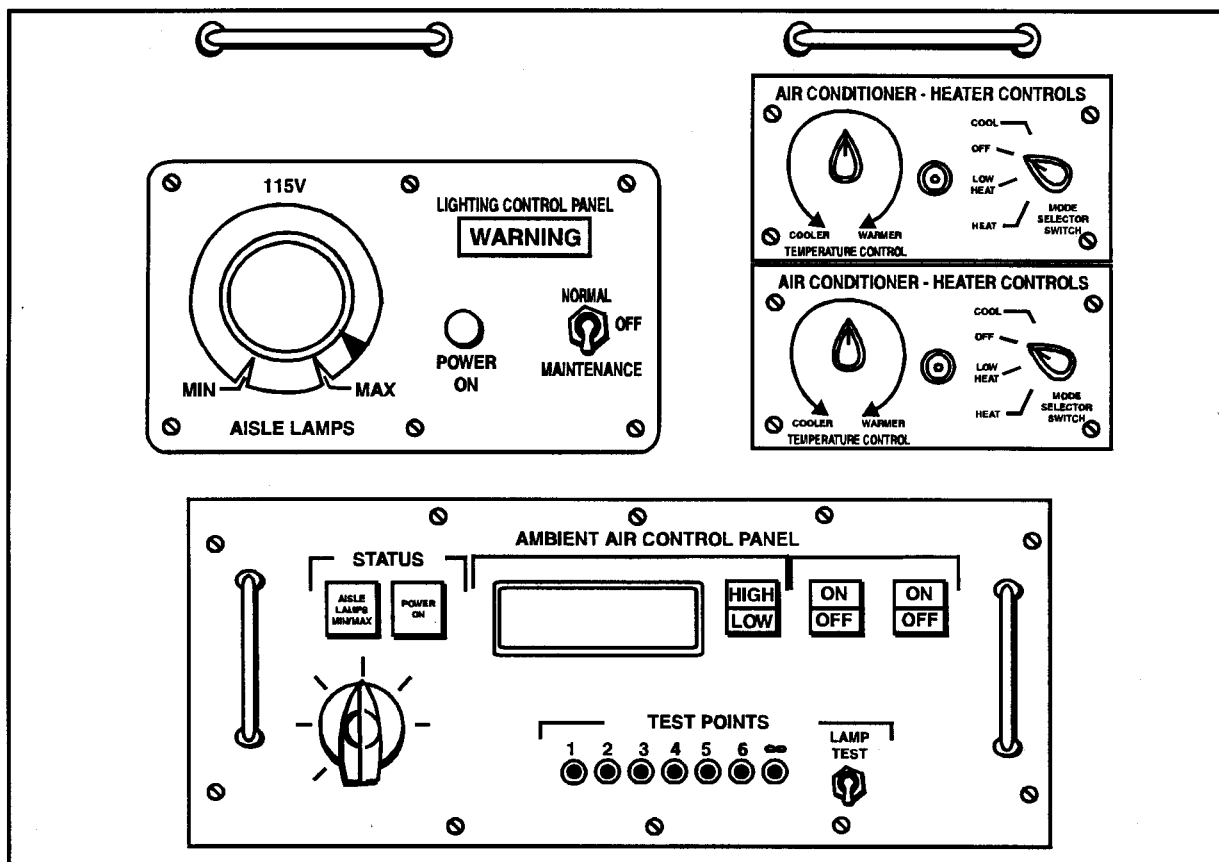

Figure B-14. Environmental control panel.

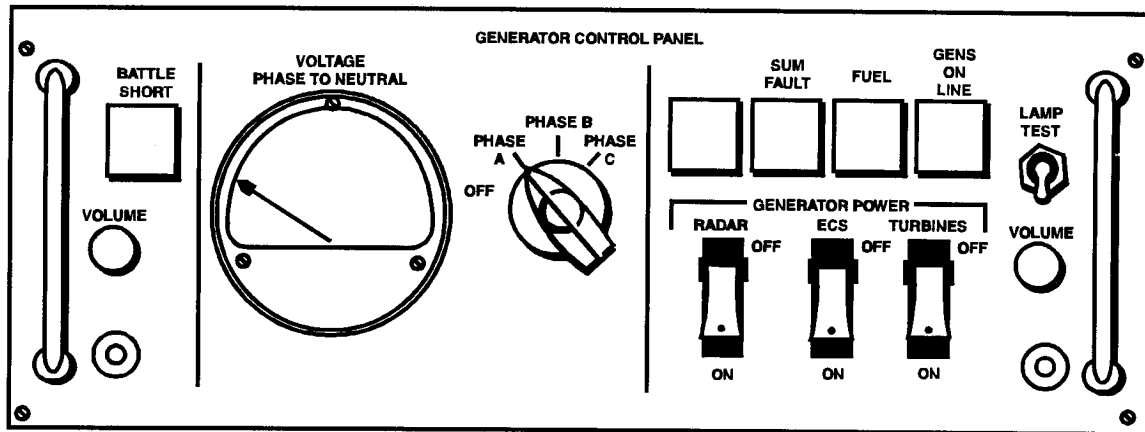

Figure B-15. Generator control panel.

decontaminate themselves, remove protective clothing, and then enter the ECS through the normal crew access door.

The air-conditioning system maintains a higher than atmospheric pressure within the shelter. Any leakage is from inside to outside, thereby preventing contaminated air seepage into the operator compartment.

POWER

A three-phase, 400-hertz power cable and a control and status monitoring cable connect

the ECS to the electric power plant (EPP). A generator control panel (Figure B-15) located between the two operators allows them to monitor the status of the EPP. The panel also provides power switches for the ECS and RS and emergency controls to shut down the EPP.

The power distribution panel mounts circuit breakers and run time meters for shelter equipment. It is located between the two operator stations at floor level.

PATRIOT BATTALION FIRE DIRECTION CENTER EQUIPMENT

The Patriot FDC is located in the battalion ICC shelter.

SHELTERS

With a few exceptions, the ICC shelter configuration is identical to that of the ECS. The ICC, shown in Figure B-16, is housed in the same type of shelter as the ECS; it contains the same environmental and power control assemblies, the same UHF equipment, the same two display consoles (the status panel has labeling and functions consistent with battalion operations), and the same peripheral equipment for the WCC. Its computer is the same basic

unit as that of the ECS. A modification to the ICC has added a second CPU to meet Patriot-Hawk interoperability requirements.

A few physical differences distinguish the ICC from the ECS. The ECS contains the RWCIU and the VHF data link terminal, and the external VHF antenna mast. These items are not in the ICC. The ICC contains modems to permit communications with AD elements that do not use the Patriot data information link. The dimensions and weight of the ICC are listed in the section, Tactical Equipment, Weights and Dimensions, at the end of this appendix.

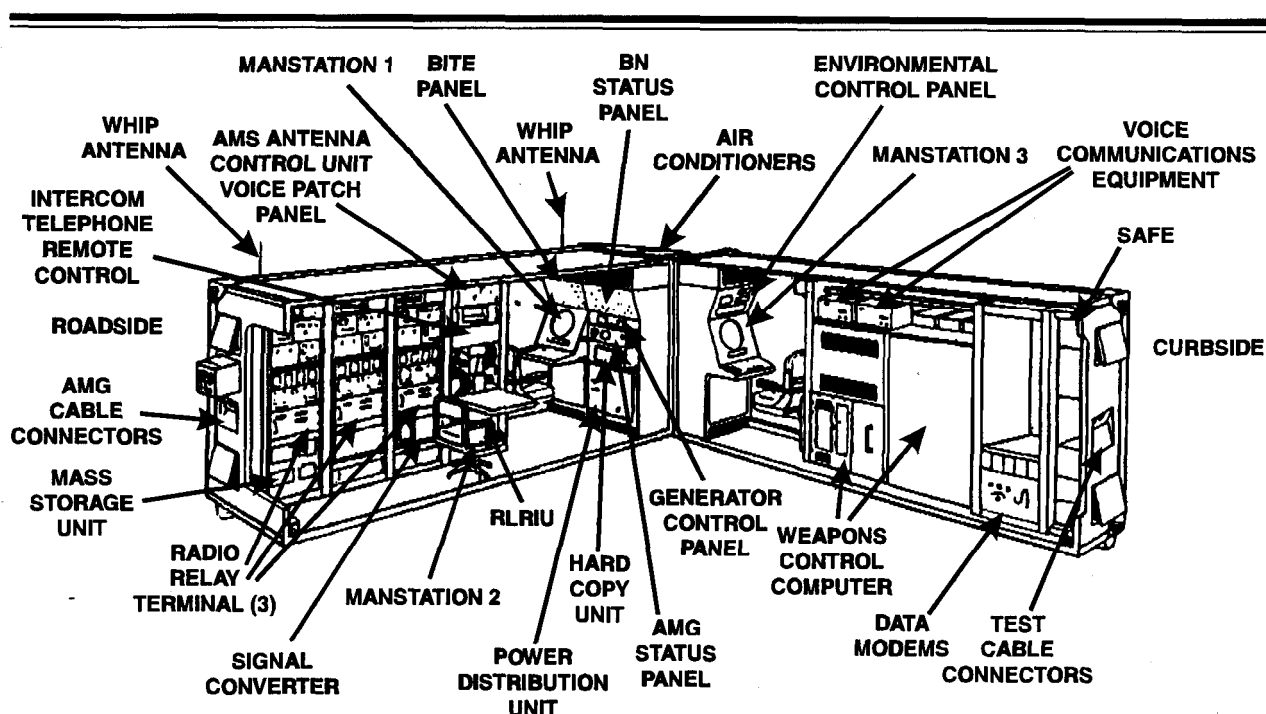

Figure B-16. Cutaway view of the ICC.

COMPUTER PROGRAMS

The ICC computer programs process the data received from the battalion's FUs, from adjacent AD elements, and from higher echelons. The ICC facilities allow efficient and effective coordination of all operations, including engagement actions of FUs under its command. These programs are organized in groups similar to those described for the ECS.

System Initialization

This group performs the collection and storing of all necessary data relative to the deployment of the organization. This includes location and orientation of FUs in the organization; location, size, and value of defended assets; friendly aircraft protection boundaries; and restricted zones. The ICC can assist in loading much of their required database via the UHF data link.

Deployment Command Plan

The deployment and or command plan function provides the battalion commander with the capability to alter the tactical data base or to plan future battalion deployments. The data base contains tactical information, FU locations, communications antenna azimuth and linkages, identification data, and engagement parameters. It is preplanned and stored on tape for rapid access and transmission.

Air Defense Mission

The battalion receives its AD mission in the form of assets or forces to be defended. Before these can be assigned to any FU, at least one deployment must be designed. Two more designs relative to the mission for each FU may be prepared later during tactical operations.

System Operation

These programs control the display and communications equipment within the ICC on a real-time basis. They also perform the following command and coordination functions:

- Managing target track data received from the unit's FUs, adjacent Patriot units, and higher echelons. This includes correlating track data, ECM data, and engagement status data received from multiple sources.
- Status monitoring of hardware elements within the ICC, of the data links with other AD elements, and of the units within its command.
- Evaluating track identity data received from the battalion's FUs, adjacent battalions, and higher echelons. This evaluation assures proper resolution of any conflict in identification data received from multiple sources. Both passive and active (identification, friend or foe) identification parameters are considered in this process.
- Assessing the threat to determine which non-TBM targets the unit should engage, the order of engagements, and which FU should conduct the engagement.
- Displaying results from all these processes to the operators. The system, depending on the designated method of control and mode of operation, will either automatically issue the appropriate engagement commands to the FUs or

will wait for an operator-initiated engagement command. The operator can override any automatically initiated engagement action.

Diagnostics

This group of programs, very similar to those at the ECS, provide automated assistance for rapid location of failed components within the ICC. The fault isolation display aided procedures called up by the operator will display the step-by-step repair procedures to permit the operator to isolate the problem.

Training

The ICC program package includes a TPT software package. The TPT assists the unit in the sustainment of operator proficiency. The FUs additionally have the terrain map trainer (TMT) for operator mapping proficiency.

ELECTRIC POWER UNIT

The EPU II is the prime power source for the ICC and CRG. The EPU II is a 30-kilowatt, 400-hertz, diesel engine generator set mounted on a trailer and towed by the ICC or CRG. The ICC and the CRG are assigned two power units each.

COMMUNICATIONS RELAY GROUP

The CRG (see Figure B-17) provides a multiroute secure, two-way data relay capability between the ICC and the FUs and between adjacent units. The CRG provides automatic logic routing for the data and manual patching of voice channels. The CRG also provides the capability for both data and voice exit and entry for communications with elements external to Patriot. Two AN/VRC-46 type radios provide command, administration, and logistics communications within the battalion. The communications equipment in the CRG is identical to that used within the ECS and ICC. With a few exceptions,

the CRG shelter configuration is identical to the ICC. Externally, the CRG and ICC are identical. The internal arrangement of the CRG is shown in Figure B-17. The CRG has no WCC and no MS1 and MS3. A fourth UHF stack and a work area have been added. A rearranged forward end provides work space and a storage area for spare UHF equipment. The dimensions and weight of the CRG are shown in the section, Tactical Equipment, Weights and Dimensions at the end of this appendix. An EPU II, towed during road march, provides power when the CRG is deployed.

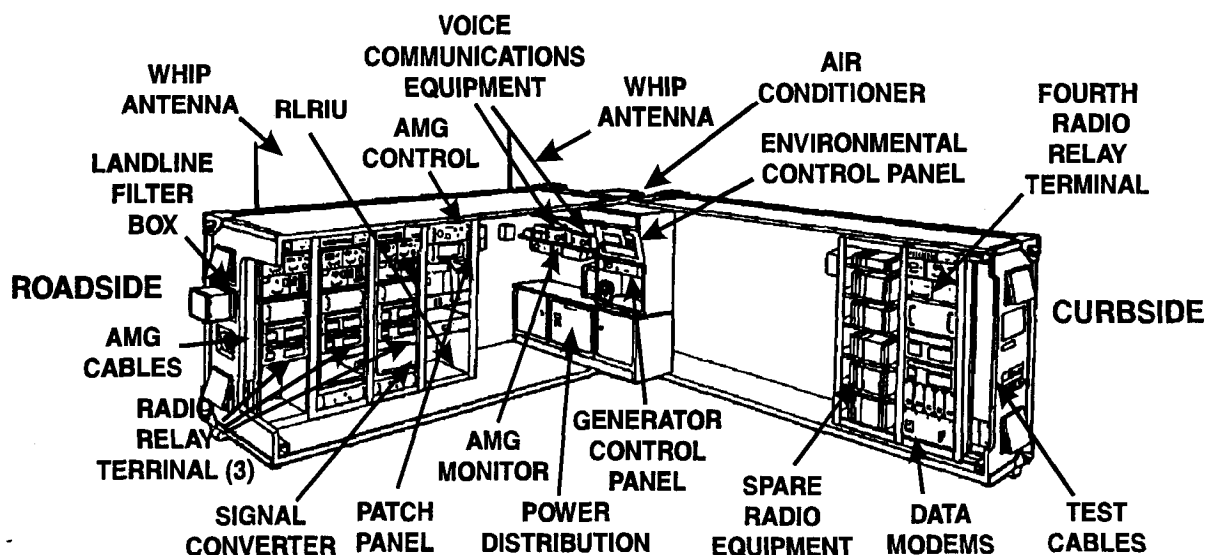

Figure B-17. Cutaway view of the CRG.

ANTENNA MAST GROUP

The AMG is a mobile antenna mast system used to carry the amplifiers and antennas associated with the UHF communications equipment in the ECS, ICC, and CRG.

The AMG includes four antennas in two pairs on remotely controlled masts. The antennas can be controlled in azimuth, and the masts can be elevated to 100 feet 11 inches above ground level. Mounted at the base of each pair of antennas are two high-power amplifiers associated with the antennas and the radios in the collocated shelter. The radios use the antenna amplifier system with several amplifier power options as conditions require:

- Bypass the amplifier.
- Use low-power amplification.
- Use full amplification.

The AMG carries the cables needed to connect the antennas to the collocated shelter. Included on the AMG are RF cables, antenna control cables, and primary power cables. In addition to the UHF radios in the collocated

shelter, there are two units installed to support the AMG operation: the antenna control unit shown in Figure B-18, page B-24, and the antenna mast monitor panel shown in Figure B-19 on page B-25.

The antenna control unit is used to remotely control and indicate the azimuth orientation of the antennas. The AMG mast monitor panel indicates the vertical orientation of the AMG antennas and provides an alarm when critical motion has occurred due to high-wind conditions.

The AMG is emplaced and the antennas deployed using self-contained hydraulic and pneumatic systems powered by onboard vehicle dc or ac power provided by the collocated shelter. Emplacement consists of stabilizing the AMG, setting the antenna feed and adjusting the antenna elevation as necessary. The antennas are deployed by hydraulically raising the masts to a vertical position and pneumatically extending the antennas to the desired height.

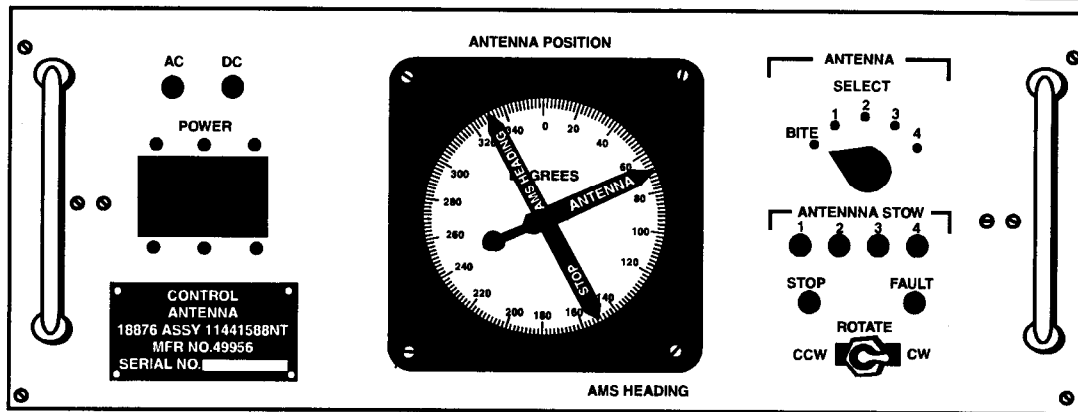

Figure B-18. Antenna control unit.

RADAR SET, SEMITRAILER-MOUNTED, AN/MPQ-53

The RS consists of a multifunction phased-array radar mounted on an M-860 semitrailer. The RS is towed by an M983, heavy expanded mobility tactical truck (HEMTT). The RS is powered by the EPP III. It is monitored and controlled by the ECS through the RWCIU.

elevated, the antenna can be trained in azimuth by means of a motor driven pedestal assembly which supports and rotates the entire radar shelter. The shelter can be positioned remotely from the ECS or locally by use of a handheld control. Prime power and the RWCIU data link signals are transferred from the fixed pedestal to the rotating shelter through slip rings in the pedestal.

THE PHASED-ARRAY RADAR

The phased-array radar, under control of the ECS, is unmanned in the operating mode. It contains BITE, which reports the complete radar status to the WCC every 15 seconds. The operators at the ECS can optionally implement special radar diagnostic checks. They can also remotely activate and deactivate the transmitter and set search track volumes for the antenna. The interfacing data link to the ECS is via shielded cable to protect against EMI and EMP.

OTHER EXTERNAL CHARACTERISTICS

Other external characteristics of the radar shelter include electronic equipment cooling air inlet and exhaust hoods. The shelter has high-level electronics (transmitter) and front-end electronics access doors, equipment storage bays, comparator assembly, and a maintenance crew entry door. The crew door provides access to low-level electronic components inside the shelter.

PHASED-ARRAY RADAR ANTENNA

The phased-array radar antenna is positioned at an angle, relative to the horizontal plane, during emplacement of the RS. Integral leveling equipment on the M860 semitrailer permits emplacement on slopes of up to 10 degrees. When fully

MAJOR EQUIPMENT GROUP SUBSYSTEMS

There are 10 major equipment group subsystems in the RS:

- Shelter.
- RWCIU.
- Control unit group.

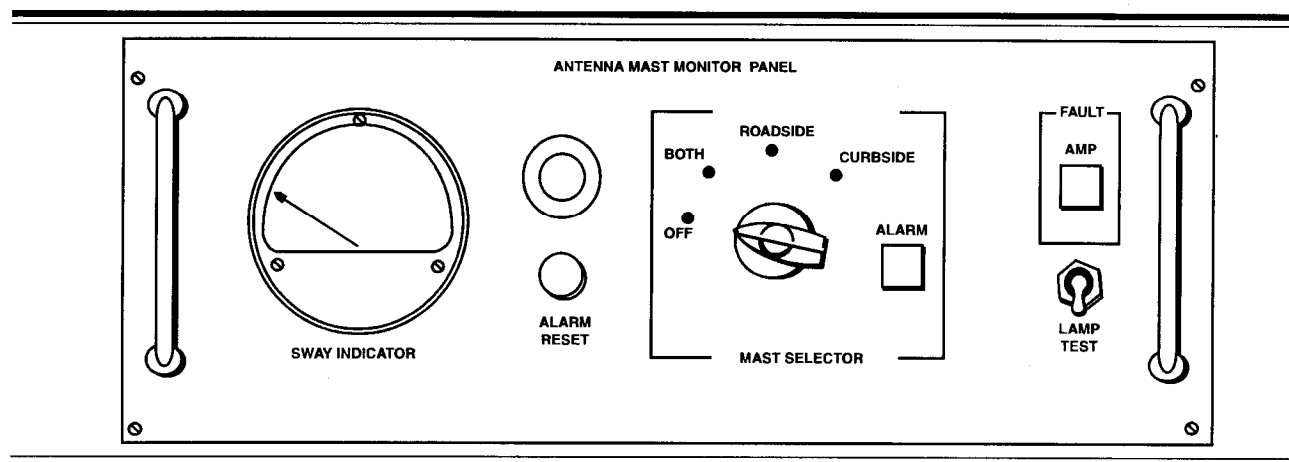

Figure B-19. Antenna mast monitor panel.

- RF exciter.
- Radar transmitter group.
- Radar antenna system group.
- Radar receiver group.
- Signal processor group (SPG).
- Identification, friend or foe (IFF) group.
- Environmental control group.

RADAR SUBSYSTEMS

The radar subsystems are equipped with BITE, display lamps, and BITE options located on test panels. Subsystems are scanned every 15 seconds for operational condition and the data is sent via the RWCIU cable to the ECS. The ECS automatically shuts down the radar transmitter in case of system failures.

Shelter

The RS shelter is an RFI and weather-tight enclosure with appropriate air inlet and exhaust ports for the environmental control systems.

The enclosure is a multicompartamental structure consisting of a central, full length, interior aisle (see Figure B-20, page B-26), and nine exterior access bays. There are four access bays on curbside, four on roadside, and one forward. The low-level electronic units

(receiver signal processor and control unit group) are bulkhead-mounted on each side of the interior aisle. The transmitter group is divided between the center curbside and roadside bays. The liquid cooling pumping unit is located in the aft curbside bay.

The forward roadside and curbside utility bays house the IFF, RWCIU, pressure dehydrator, miscellaneous power supplies, ambient air blowers for the low-level electronics cooling system, and the local RS status and control panel. Two of three digital signal processor units are in the roadside utility bay and one is in the maintenance aisle on the roadside.

The M2 aiming circle, prism, and M1A1 gunner's quadrant used for system orientation and alignment are located in the forward curbside utility bay. The antenna travel cover and the maintenance weather shields are stored in the aft roadside utility bay.

Radar Weapon

Control Interface Unit

The RWCIU is a duplicate of the RWCIU in the ECS. It accepts and decodes radar messages from the ECS and encodes and transmits radar messages to be returned. The input/output

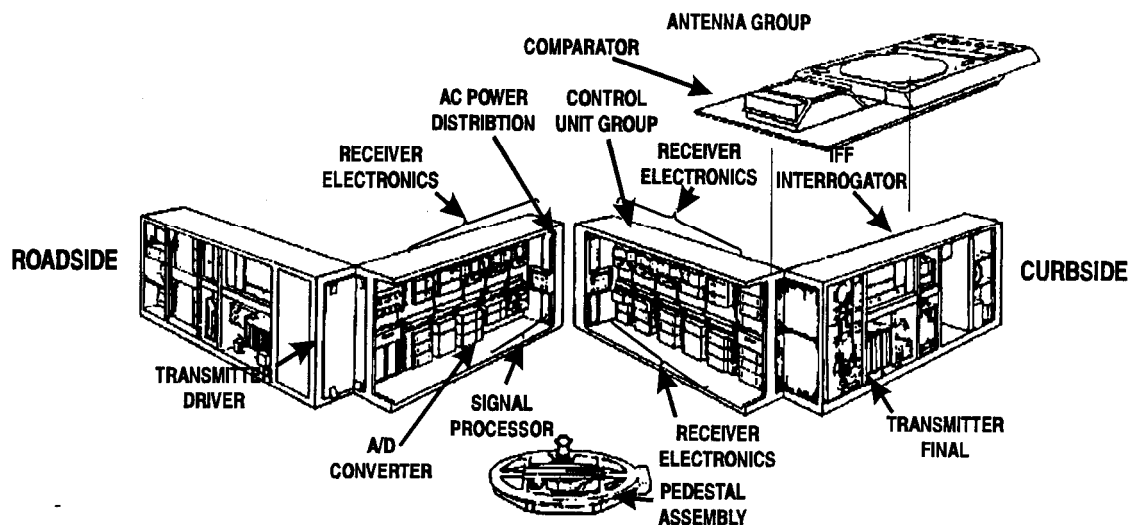

Figure B-20. Cutaway view of radar set.

device for the RWCIU at the radar interface is called the control unit group (CUG).

Control Unit Group

The CUG is the two-way data exchange interface between the RWCIU and the remainder of the radar. It acts essentially as a special purpose computer with logic circuits and hardware that enable it to form and route trigger pulses in response to instruction routines stored in memory. When an ECS radar action message dictates, the CUG sets up the radar for the requested activity. The unit then generates trains of electronic impulses used for synchronization and timing. The CUG accepts and formats radar return messages and delivers them at the appropriate time to the RWCIU (and thus to the computer). The CUG subsystems include the radar input output unit, a trigger generator, IFF interface unit, and antenna beam steering microprocessor. The CUG mounts in a three-tiered module rack assembly. The

rack is forward on the upper right side of the crew maintenance aisle.

RF Exciter

The RF exciter performs two main functions. It translates an IF waveform to one of multiple C-band frequencies for amplification and transmission. It also generates three discrete low-level radio frequency signals (L01, L01 *, and L02) for RF signal conversion at the radar receiver group.

Radar Transmitter Group

The transmitter amplifies the RF waveforms used for the surveillance and guidance functions of the radar. The radar action messages from the WCC to the CUG select the appropriate waveform characteristics for timing, pulse width, single- or multiple-pulse groupings, and high- or low-power level. The waveform sets, after conversion by the exciter to C-band, are amplified in the driver and final stages. The transmitter maintenance upgrade

(TMU) increases organizational maintenance capability for the transmitter and reduces transmitter mean time to repair (MTTR).

Radar Antenna System Group

The radar antenna system group consists of the lens assembly and the comparator assembly. The lens assembly is hinged at the forward end of the shelter. The comparator assembly mounts at the lens focal point on the shelter rooftop.

The comparator assembly. The comparator assembly contains the radiating, high-power output horn. The horn is connected, via the waveguide, to the transmitter. In the transmit mode, the transmitter horn illuminates the 5,161 element lens of the main phased-array antenna. The array electronically steers the beam by loading into the elements the appropriate phase commands for the desired steering angle.

In the receive mode, the lens focuses the RF into the receiver horn in the comparator assembly. The comparator forms sum and difference channel information by means of microwave arithmetic networks. The sum, azimuth difference, and elevation difference signals pass to the receiver front ends. After frequency conversion and filtering, the received energy, at intermediate frequency (IF), passes down into the shelter to the receiver group circuitry.

The lens assembly. The lens assembly, shown in Figure B-21, houses the main antenna array, a TVM array, an IFF array, and the auxiliary arrays. Energy received by the TVM and auxiliary arrays is passed, via flexible shielded cable, from the lens assembly to the receiver group. A clutter canceller modification has been added to the TVM correlation processor (TVMCP), which cancels radar returns from stationary targets, permitting only moving targets to be processed by the signal processor group (SPG).

The radar status and control panel provides a local means of controlling main power. It

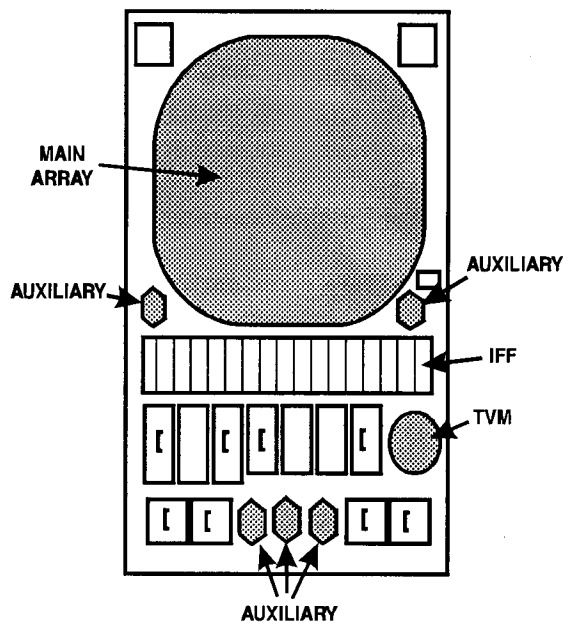

Figure B-21. Antenna lens assembly.

also permits erecting and lowering the antenna lens assembly.

The lens assembly is positioned by electrically driven jackscrews. The jackscrews push the base section up and out to rotate the antenna back onto the shelter roof for horizontal storage and travel. The same jackscrews are reversed to pull the antenna base down toward the shelter. The base is pulled against the mechanical stops and throw-out switches to ensure that the antenna is firmly locked at the proper elevation angle during operation.

Radar Receiver Group

IF returns are routed inside the shelter to the RRG. The subassemblies of this group, the low-level electronics, form the bulk of all units in the shelter interior.

The receivers in the RS perform such functions on the received signals as sensitivity time control, pulse compression, gain control, range gating, correlation, ECM sensing,

ECCM implementation, and conversion to video for signal digitizing. The three search and track receiver channels (one sum and two difference channels) are located at the upper roadside of the shelter maintenance aisle. A fourth channel is for sidelobe blanking. It is located next to the search and track channels. Diagonally across the aisle, and occupying more than half the space on the curbside, are the TVM correlation and TVM analog processors.

Outputs of the ECCM receiver are coupled from the receiver group assemblies to the CUG for transmission to the ECS. Search and track receiver, and TVM receiver outputs are fed to the radar signal processor.

The RRG also includes the waveform generator and pulse expansion units. These devices supply the waveforms for the radar transmitter.

The RRG consists of a total of 29 interconnected module rack assemblies of 19 different types plus two receiver front-end assemblies. The module rack units are single-, double-, and triple-tiered assemblies.

A module rack assembly consists of both module and receiver unique hardware. The assemblies are interconnected via nine-layer motherboards which contain all of the power and approximately 80 percent of the signal interconnections.

Signal Processor Group

The SPG performs analog-to-digital (A/D) conversions and subsequent high-speed digital processing of all video signals from the receiver. The ECS, in each radar action message, sets up the signal processor group. Modules of the signal processor are housed in the lower roadside section of the shelter maintenance aisle and in the roadside utility bay. The SPG consists of three-tiered module rack assemblies, a single rack assembly, and an A/D converter rack.

Identification, Friend or Foe Group

The IFF group consists of an electronically steerable IFF antenna array located on the antenna lens assembly, and an IFF interrogator set (AN/TPX-46[V]7), located in the forward curbside shelter utility bay. The IFF group is controlled and timed by the IFF interface unit in the control unit group, according to instruction messages from the WCC.

Environmental Control Unit

The radar ECU equipment provides temperature control for operation of radar unit subsystems. Low-level electronics are cooled by a flow of outside ambient air, pulled into the shelter through RFI-shielded inlet ports in the maintenance aisle door. The cooling air is drawn through the electronic modules, into central air ducts, and exhausted through ports located in the roadside and curbside utility bays.

For operation at low outside temperatures, a system of pneumatically-driven louvers recirculate exhaust air back into the aisle. The louvers recirculate the air when temperatures are below 70° F.

Transmitter ambient air cooling is accomplished by means of vaneaxial blowers. These blowers are located in the forward end of the shelter, above the PDU. The blowers draw air in through the RFI-shielded ports in the power distribution unit doors, blow it through the transmitter electronics, and exhaust it overboard through ports in the utility bays.

A high-capacity liquid cooling pumping unit (cooler, liquid, and electron tube) is located in the aft, curbside bay of the shelter. The cooling pump cools high-power components of the transmitter. Liquid coolant is circulated to power supplies, modulators, low- and high-power transmitter tubes, and critical microwave components.

A pressure dehydrator unit, located in the forward roadside utility bay, provides dry air

for pressurizing the waveguide to gauge pressures of 26 PSI. Reduced airpressure is also supplied to the transmitter driver at 11 PSI.

Automatic Emplacement Enhancement

The automatic emplacement enhancement (AEE) consists of the following two hardware components:

- Global Positioning System (GPS).
- North Finding System (NFS).

Together these units automatically perform the operator alignment functions which generate location, azimuth angle, roll and cross-roll for the system. FU software programs are modified to account for this new capability.

Global Positioning System. The GPS is one component of the AEE. The GPS operates passively, gathering positioning data from a number of satellites, allowing an unlimited number of users to simultaneously acquire precise position and navigation data under all weather conditions at anytime of day or night. The GPS provides location and elevation data for each LS and RS. A minimum of four satellites is required to ensure accurate position and altitude information.

The GPS receiver, AN/VSN-8, is located in the curbside utility bay of the RS and on the turntable pedestal on each LS. On the RS, the GPS antenna is attached to the top of the main antenna array while on the LS, the GPS antenna is attached to the DLT antenna mast support. The GPS has onboard BIT. The display unit displays a failure code and test sequence number when a fault is detected by BIT. Using the Failure Code and a Fault Isolation Table in TM 11-5825-275-23, the LRU most likely to have caused the problem can be replaced. To retain satellite data and time when vehicle power is removed, the GPS has memory batteries. These are three AA

alkaline batteries (BA-3058/U) (NSN 6135-00-935-3587) which are changed semiannually.

GPS provides accurate position, altitude, and time information on a continuous, world-wide basis. This information is provided at two accuracy levels through the standard positioning service (SPS) and the precise positioning service (PPS). SPS is a civil position/navigation service providing the lower accuracy available to any user. The PPS is a military service providing higher accuracy. PPS is restricted to US and allied military forces and, if in the national interest, to selected civil users. The satellite transmits a "coarse acquisition" code called C/A code, and a "precise" code, called P code. The user is able to obtain a more accurate position and velocity solution when using P code than when using C/A code (16 meters circular error probable [CEP] versus 100 meters).

PPS is implemented with selective availability (SA) features. SA denies the unauthorized real-time user of the full PPS accuracy. Cryptographic measures are integral to SA requiring cryptographic keys to gain access to full PPS accuracy.

PPS is also implemented with antispoofing (AS) features that protect GPS users from transmitters that intentionally mimic GPS navigation signals (spoofing or beaconing). Cryptographic measures are also integral to AS. The cryptokeys are stored in the GPS receiver using a standard KYK-13. Two types of cryptokeys are used by the GPS. They are a group unique key (GUK) and a cryptokey weekly (CKW). The GUK is normally good for a year, while the CKW is good for seven days. The Army is currently issuing the yearly codes (GUK).

North finding system. The NFS part of the AEE provides the azimuth and roll information

for the RS and each LS. The NFS is also referred to a bearing-distance-heading indicator (BDHI). The NFS is located adjacent to the GPS on both the RS and LS. It is a gyrocompass-based system which senses the platform attitude with respect to the earth's true north reference. NFS will determine that azimuth orientation of the RS or LS over the range of 0 to 6399.9 roils with a plus or minus 2.0 roils accuracy. The NFS provides this azimuth accuracy throughout much of the world where

Patriot is expected to be deployed. NFS provides roll and cross-roll measurements within the range of plus or minus 100 mils (-5.6 to +5.6) with an accuracy of plus or minus 2.0 mils. See FM 44-85-1 (TBP) for additional information.

The NFS has a built-in self-test that is accomplished within 20 seconds of power application. Built-in test equipment (BITE) will detect 99 percent of the NFS mission-oriented faults and isolate the malfunction to a battery replaceable unit (BRU).

ELECTRIC POWER PLANT, TRUCK-MOUNTED

The electric power plant (EPP) is the prime power source for the ECS and RS which, together with EPP and AMG, comprise a Patriot fire control section. Each EPP consists of two 150-kilowatt, 400-hertz diesel engines which are interconnected through the power distribution unit. Each EPP contains two interconnected 283.9-liter (75-gallon) fuel tanks, and a fuel distribution assembly with grounding equipment. Each diesel engine can operate more than eight hours with a full fuel tank. It is recommended to switch generators every eight hours for maintenance checks and services.

The power cables for the RS and ECS and the EPP control cable are stowed on cable

racks on the roadside outer section of the truck body. One power cable and the control cable connect to the ECS, while the remaining three power cables connect to the RS. The control cable connection to the ECS allows fire control operators to control the power distribution unit connectors and circuit breakers. The connectors provide power to both the RS and the ECS. The control cable also provides the ECS with a low-fuel warning and EPP emergency shutdown capability. Each power cable is interlocked so that power is not available through it until it is terminated on both ends. A sound power telephone jack at the EPP provides communications with the ECS or RS.

LAUNCHING STATION, GUIDED MISSILE, SEMITRAILER-MOUNTED, M901

The LSs are remotely-operated, fully self-contained units that can carry up to four guided missiles. The ECS controls operation of the LS via FO or VHF data link. The LS is mounted on an M860 semitrailer towed by an M983 HEMTT, as is the RS.

Integral leveling equipment permits emplacement on slopes of up to 10 degrees. The LS is trainable in azimuth and elevates to a fixed, elevated, launch position. Precise aiming of the LS before launch is not necessary, thus no extra

lags are introduced into system reaction time.

At the LS, BITE automatically monitors all critical electronics and guided missile functions. Status reports are returned periodically to the ECS.

The ECS sends missile prelaunch guidance messages and launch command instructions via the FO data link. On command from the ECS, the LS initiates an automatically sequenced missile countdown. The countdown includes loading the prelaunch

guidance messages into missile memory.

The LS weights and dimensions are listed in the section, Tactical Equipment, Weights and Dimensions, at the end of this appendix.

The LS contains four major equipment subsystems (Figure B-22, page B-33). The four subsystems have the following designations and roles in Patriot system performance:

- The launcher generator set—the onboard source of LS electrical power.
- The launcher electronics assembly—two trailer-mounted equipment consoles function in dual modes as follows: receive, decode, and execute commands of the ECS, and communicate the LS and missile status and the results of recently commanded actions back to the ECS.
- The launcher mechanics assembly—elevates the guided missiles and contains a data link antenna mast for communications with ECS.
- The launcher interconnection group—interconnects onboard LS equipment and controls the routing of electrical function lines to and from the guided missiles.

LAUNCHER GENERATOR SET

The generator for the LS is located on the yoke assembly of the trailer and includes a built-in, 56.8-liter (15-gallon) base fuel tank. It is adjoined by side-mounted work platforms. The unit is a diesel engine-driven generator, rated at 15 kilowatts, which provides three-phase, four-wire, 400-hertz, 120/208-volt power. It is recommended that the LS be refueled every eight hours to ensure continuous operations.

LAUNCHER ELECTRONICS ASSEMBLY

The launcher electronics assembly consists of two functional equipment modules located on the trailer bed aft of the electrical generator.

The modules are below the stowed LS platform when march ordered.

Launcher Electronics Module

The LEM is used for the real-time implementation of LS operations requested via data link from the ECS.

Azimuth and elevation toggle switches on the front console control panel permit manual elevation and rotation of the LS. A toggle switch enables BITE tests to run, and a pair of rotary switches dial LS and group designations for display at the ECS. A key switch enables the LS to be remotely controlled by the ECS.

Elsewhere on the control panel, a total of 23 display lamps show missile and LS equipment status. Three of the lamps verify the configuration of the LS for travel or launch modes, five lamps indicate BITE test results, three lamps indicate power supply status, and three groups of four lamps indicate the status of each missile.

Data Link Terminal Module

The DLT module on the curbside forward end of the trailer acts as an encoding-decoding unit, event timer, and transmitter and receiver for the digital communications link between the LS and the ECS. All items in this group are comparable to components of the DLT module found at the ECS.

LAUNCHER MECHANICS ASSEMBLY

The LMA consists of an LS platform, platform erection system, and a motor-driven pedestal assembly. The launch platform has two elevation positions: horizontal for travel and GM loading, and 38-degree elevation for launching. Elevation and azimuth drive controls on the roadside control panel of the launcher electronics module provide control of launcher platform orientation during emplacement.

Azimuth reorientation is possible by remote control from the ECS and is used only when radar retraining requires a different launch angle. The elevation linkage for the mechanical assembly also raises and lowers the data link antenna.

LAUNCHER INTERCONNECTION GROUP

The LIG consists of the network of external missile data and power cables, plus a launcher missile-round distributor. The launcher

missile-round distributor is located on the aft end of the elevating LS platform. It provides an electronic switching matrix for automatically interconnecting launch functions of a single input cable to one of four output cables connected to the canisters. Electrical interconnections to the guided missiles are made through a multiple-pin connector located below and to the left of the rear blowout cover of the canister. The launcher missile round distributor also includes sensing and command lines plus circuitry for control of missile onboard heaters.

PATRIOT GUIDED MISSILE, INTERCEPT AERIAL, MIM-104

The Patriot guided missile consists of a missile mounted within a canister that is the shipping and storage container and the launch tube. Guided missiles are stacked in groups of four per LS. For loading purposes, a guided missile is lifted by hoist fittings and lowered so that four alignment holes match with four pins in the support frame. The bolts secure two lower guided missiles side-by-side on the frame. These in turn, serve as support and alignment structures for two additional guided missiles. The upper side of the canister support frame contains pins which mate with the underside holes of the upper missile canisters to be loaded.

On the aft end of the guided missile, a desiccant indicator monitors the humidity within the canister. A single umbilical cable connects the canister with the LS and provides the means for status monitoring, preheating, and launching.

The missile has four clipped-delta, all-movable tail control surfaces. It is propelled by a single-stage, all-boost, solid-propellant rocket motor.

BITE checks missile readiness and provides GO/NO-GO logic for successive events in the countdown. A malfunction in any lead-in event in the missile activation and arming

sequence will prevent rocket motor ignition. The defect is automatically reported to the WCC in the ECS.

GUIDED MISSILE

The missile, from front to rear, consists of a radome, guidance section, warhead section, propulsion section, and control actuator section (Figure B-23, page B-34).

Radome

The radome is made of slip cast fused silica approximately 16.5 millimeters (0.64 inch) thick, with nickel alloy tip, and a composite base attachment ring bonded to the slip cast fused silica and protected by a molded silicone rubber ring. The radome provides an aerodynamic shape for the missile and microwave window and thermal protection for the RF seeker and electronic components.

Guidance Section

The Patriot guidance function is performed by the modular digital airborne guidance system (MDAGS). The MDAGS consists of a modular midcourse package which performs all of the required guidance functions from launch

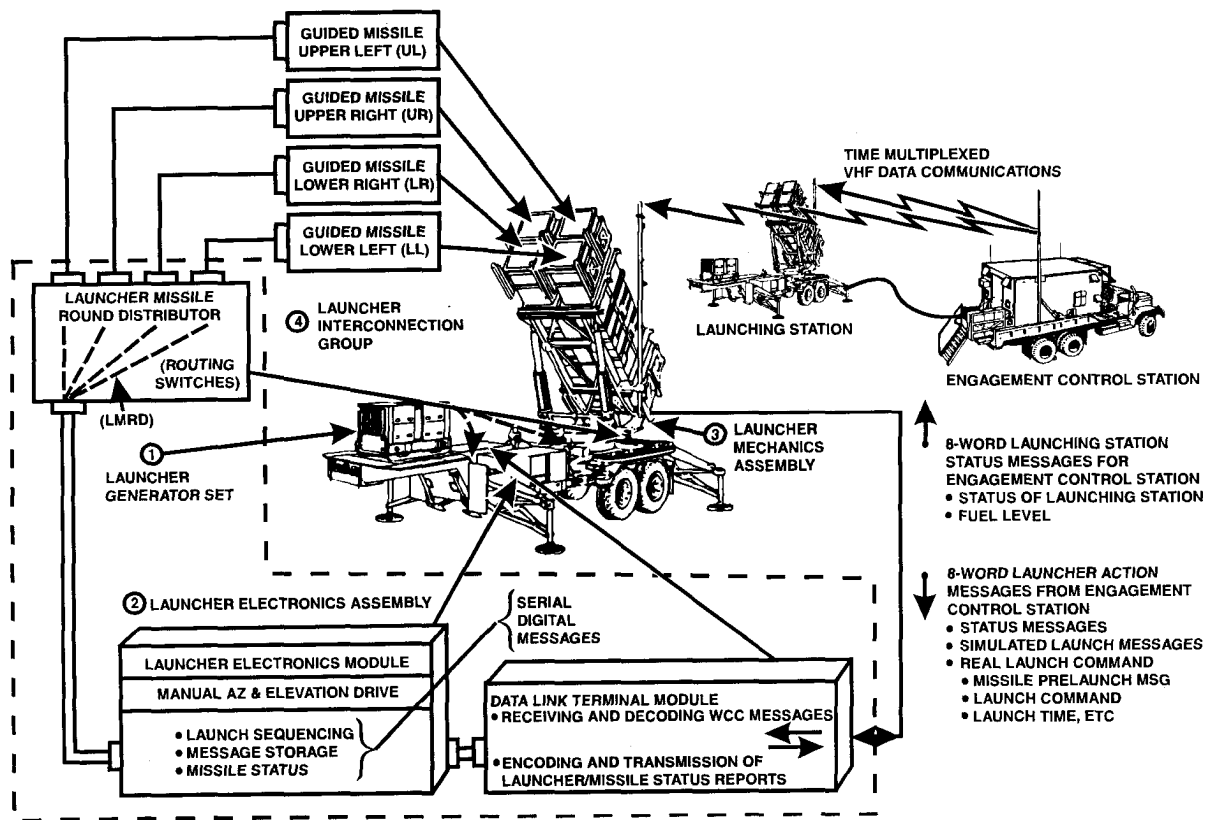

Figure B-22. Launching station system configuration.

Warhead Section

The warhead section, just aft of the guidance section, contains the warhead, safety-and-arming device, fuzing circuits and antennas, link antenna switching circuits, auxiliary electronics, inertial sensor assembly, and signal data converter.

Propulsion Section

The propulsion section consists of the rocket motor, external heat shield, and two external conduits. The rocket motor includes the case, nozzle assembly, propellant, liner and insulation, pyrogen igniter, and propulsion arming and firing unit. The casing of the motor is an integral structural element of the

through midcourse and a terminal guidance section.

Missile Seeker The TVM seeker is mounted on the guidance section, extending into the radome. The seeker consists of an antenna mounted on an inertial platform, antenna control electronics, a receiver, and a transmitter.

Modular Midcourse Package The MMP, which is located in the forward portion of the warhead section, consists of the navigational electronics and a missile borne computer which computes the guidance and autopilot algorithms and provides steering commands according to a resident computer program.

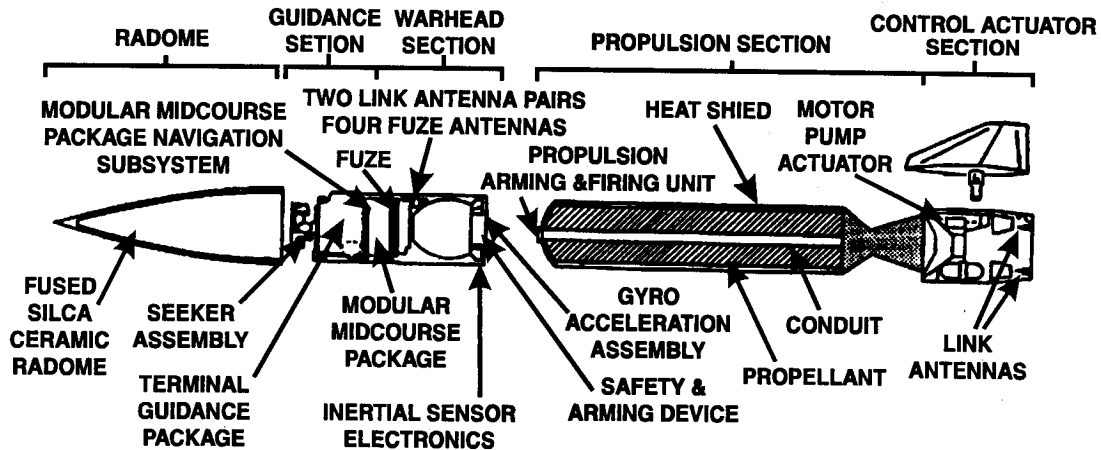

Figure B-23. Major missile sections.

missile airframe. It contains a conventional, casebonded solid propellant.

Control Actuator Section

The CAS is at the aft end of the missile. It receives commands from the missile autopilot and positions the fins. The missile fins steer and stabilize the missile in flight. A fin servo system positions the fins. The fin servo system consists of hydraulic actuators and valves and an electrohydraulic power supply. The electrohydraulic power consists of battery, motor pump, oil reservoir, gas pressure bottle, and accumulator.

MISSILE CANISTER

The canister (see Figure B-24) functions as a launch tube and as a missile shipping and storage container. It protects the missile from the time of assembly until missile launch.

The Patriot canister is a reinforced square aluminum canister made of welded flat sheet stock with a welded external frame. It incorporates internal thermal insulation, an externally mounted fiberglass and rubber flythrough front cover, and a hard fiberglass blow-away rear cover. It has externally indexed mounting and latching mechanisms for rapid attachment to the LS. It also includes lifting and towing eyes, towing skids, and forklift provisions.

Inside the canister, the missile is supported on two aluminum longitudinal rails and adjustable upper and side support shoes. Longitudinal support is provided by a restraint pin which is unlocked for emplacement and relocked by the torque handle for road march.

At launch, each missile blasts away its aft canister cover and flies through its forward cover. Individual canisters may be removed and new guided missiles reloaded, as needed.

PATRIOT MAINTENANCE SUPPORT

Organizational-level maintenance personnel from the battery and battalion perform preventive and corrective maintenance on the

Patriot system by replacing battery replaceable units (BRUs). The organizational maintenance capability is backed up by intermediate

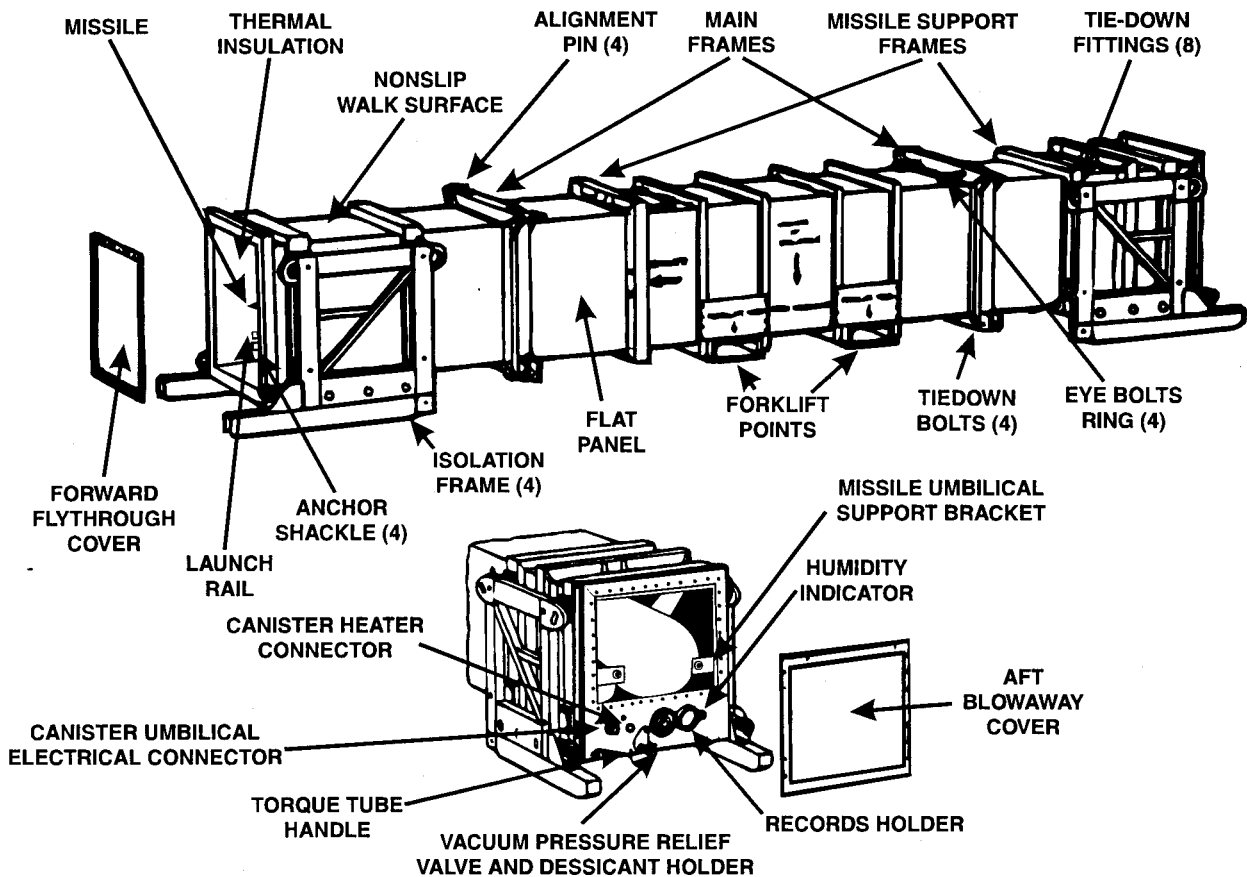

Figure B-24. Patriot guided missile configuration.

maintenance contact teams to diagnose problems beyond organizational capability. The guided missile is a "certified round" with no field test or repair permitted. If missile maintenance is required, the "certified round" is returned to a Patriot missile facility. Standard army equipment such as generators, vehicles, and communications equipment in the Patriot system is supported by the conventional Army direct support (DS) and general support (GS) system.

MAINTENANCE PLAN

The Patriot maintenance plan enhances the organizational personnel's capability to perform

the level of maintenance necessary to sustain the AD mission. Included are—

- Reduction of GS maintenance equipment.
- Reduced requirements for training of operators and mechanics.
- Improved procedures for on-site maintenance, for preventive maintenance, corrective maintenance, and calibration tasks.
- Improved diagnostic capabilities to isolate faults.
- Simplified maintenance through hardware and software redesign. Utilization of the diagnostic software in the system computer provides display-aided maintenance (DAM) procedures to simplify maintenance.

PATRIOT AIR DEFENSE BATTALION

The battalion is supported for Patriot peculiar equipment through the battalion maintenance center. The center, at the HHB, has battalion maintenance equipment (BME) and a separately towed power generator.

Standard Army equipment support includes a DS activity for power generation, air-conditioning, and communications equipment. For vehicles, theater DS and GS are available.

PATRIOT FIRE UNIT

The Patriot-peculiar equipment of the FU is supported with a battery maintenance group (BMG). The BMG consists of a maintenance center, small repair parts transporter, a large repair parts transporter, and a towed 15-kilowatt power generator (PU-732/M). Standard Army equipment is supported with portable tools and test equipment stored in the maintenance center.

PATRIOT SUPPORT EQUIPMENT

The Patriot battery maintenance group and the battalion maintenance support equipment consists essentially of standard Army vehicles and equipment modified for use with the Patriot system. They provide the maintenance and supply capabilities required for selected Patriot equipment at the battery and battalion headquarters levels. Storage for repair parts, tools, handling and test equipment, publications, and maintenance and supply records are all provided with the vehicles to form a complete organizational maintenance capability.

The Maintenance Center

The maintenance center (see Figure B-25), used in both the BMG and BME, is a semitrailer mounted shop. It contains the tools and handling, and test equipment necessary to maintain the Patriot

tactical equipment. The HHB of the maintenance center has been reconfigured to also function as an SRPT. The tools and handling equipment consist of common tools and equipment plus several items of special tools and handling equipment (ST&HE) which are contractor-furnished equipment (CFE).

The power unit PU-732M is a trailer mounted, 15-kilowatt, 400-hertz, diesel generator set. It is towed by a separate vehicle and provides power for the maintenance center and small repair parts transporter not used at HHB.

The Small Repair Parts Transporter

The SRPT is used only in the FU and uses the same vehicle as the maintenance center but is normally not occupied. No environmental control is required. Storage racks, baskets, and drawers for storing small repair parts are furnished.

Guided Missile Transporter

The guided missile transporter (GMT), located normally with the HHB, is a modified HEMTT M985. It is used for delivery, recovery, and loading of guided missiles, using a heavy duty material handling crane attached at the rear of the vehicle.

Large Repair Parts Transporter

The large repair parts transporter (LRPT) provides a means to transport and store large, heavy repair parts. It consists of a HEMTT M977 cargo truck with a light-duty material handling crane.

TEST EQUIPMENT

Patriot test equipment enables crew members to maintain the system. Though

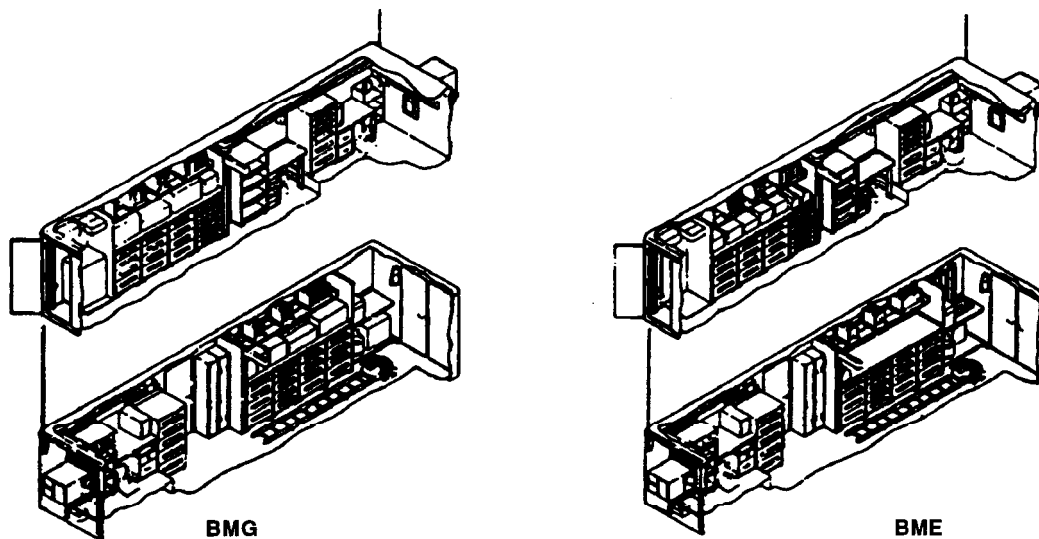

Figure B-25. Battery maintenance equipment.

most test equipment is built-in, several items are portable.

Launching Station Test Set

The launching station test set (LSTS) (see Figure B-26 on page B-38) is a portable test set stored in the battery maintenance group. Its basic function is fault localization of the launcher electronics.

Missile-Round Cable Test Set

The MRCTS (Figure B-27 on page B-39) is a portable test set used primarily to check for stray voltages and cable continuity during missile reload operations. The MRCTS is stored in the maintenance center when not in use.

Electronic Counter

The electronic counter is a portable test set. It is stored in the maintenance center. It is a time and frequency measurement device used for maintenance calibration and as a diagnostic tool in fault isolation.

The Patriot-peculiar system equipment is designed with a means of maintenance calibrating the necessary measuring devices with accuracy traceable to the National Bureau of Standards (NBS) through area support calibration team equipment. This is accomplished with the portable test equipment and calibration adapters. Much of this equipment in Patriot units is standard Army equipment. Standard equipment is supported in the conventional manner.

TRAINING DEVICES

The missile-round trainer (MRT) is a tactical canister shell with ballast permanently secured inside. It has the physical appearance, weight, and center of gravity of a tactical guided missile. An electrical simulator mounted inside the trainer canister provides electrical responses to simulate a safe missile to the launcher electronics for all functions except launch related responses.

Operator Tactics Trainer

The operator tactics trainer (OTT) simulates the Patriot ECS and ICC displays, controls,

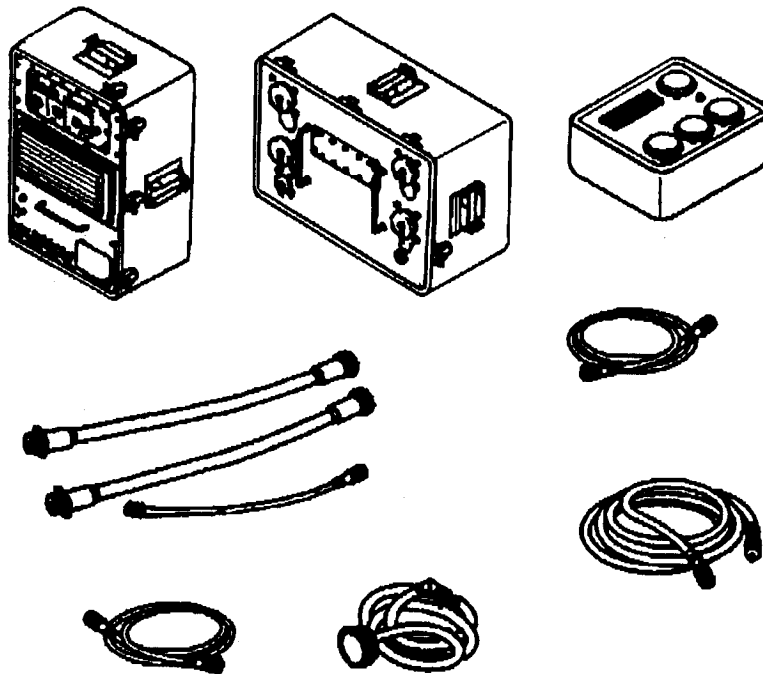

Figure B-26. Launching station test set and missile simulator.

communications, and data processing systems. The instructor station can control and monitor the simultaneous training of eight individual student operator positions. The training position consoles allow student operators to perform all actions related to initialization, monitoring, and proper use and response to displays, controls, and communications. The training equipment and interconnecting cabling allow installation in a classroom or laboratory and separate these operating groups which are not normally within the same tactical enclosure.

Operator Training Software

There are basically four types of operator training software used on the Patriot tactical system at the present time.

Troop proficiency trainer. The Patriot TPT for operator refresher training uses a software-only approach. The software-only

concept means the radar unit is not used and thus there is a completely controlled operator evaluation environment.

The TPT software can be used in either a stand-alone configuration or netted battalion configuration. In the stand-alone option, training is provided only at the using unit (ICC or FU). In the netted configuration, the ICC provides integrated C² to the ECSs and the training process as in tactical operations. The netted configuration also provides communications training. The TPT uses a taped prepared training scenario. The scenario contains primarily target and ECM data. The data base (geographic areas, etcetera) is entered by using the appropriate database tape (FU or ICC) which can be prepared using the tactical initialization programs.

During the conduct of the training, the training officer loads the software and enters the appropriate asset and target selection. In

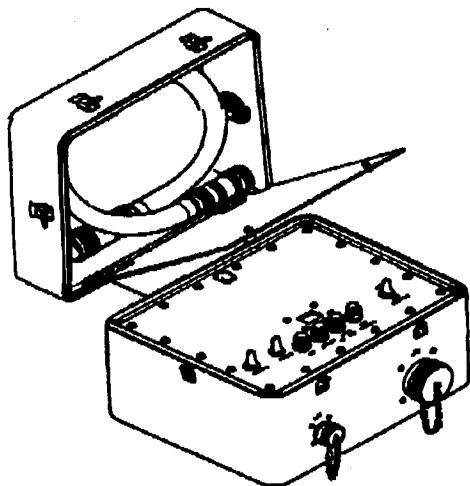

Figure B-27. Missile-round cable test set.

addition, the training officer will start or end the exercise and start the recorder for post training evaluation.

The ICC TPT is limited to use in the standalone mode. For netted training to be conducted with the FU from the ICC, the troop netted trainer (TNT) must be used. The ICC TPT and TNT present realistic images of the tactical environment in which a battalion will perform its air defense mission (ADM).

The ICC TPT and TNT provide an AD game concept in which operators allocate resources in defense of simulated assets. Realism is provided through simulation of TBM attacks. Simulated hostile aircraft perform defense suppression and confusion tactics, while attacking defended assets. During an exercise, ICC operators perform actions and tactics as they would during an actual air battle.

The ECS TPT presents an image of the environment in which a FU will perform its mission. During normal missions, the ECS functions as the operational and maintenance

control center of the FU. The ECS simulates the following operations and battle conditions:

- Detection and recognition of friendly and hostile aircraft.
- Detection, recognition, and engagement of TBMs.
- Use of ECM by aircraft.
- Loss of target tracks due to terrain masking or evasive maneuvers.
- Destruction of hostile aircraft, defended areas, and or vital assets.

The ECS TPT consists of computer software loaded into the WCC. The software includes a TPT exercise processor program, a selected scenario, and a geographic database for each scenario. The TPT exercise processor provides the controls to process the scenario. In conjunction with the scenario and geographic data base, it allows ECS operating personnel to engage simulated TBMs and aircraft to defend their assigned defended areas or vital assets as they would in an actual mission.

On-line training mode. The on-line training mode (OTM) is used with TPT software. The OTM allows the Patriot battalion to create its own exercises using locally tailored target sets.

A local target set is a group of targets created by the training officer and stored on an MSU cartridge. An individual target is defined by a flight path made up of a series of universal transverse mercator (UTM) points and altitude designations. A minimum of two to a maximum of eight points may define the flight path of a target. The target must have a defined altitude for at least the first UTM point. Thereafter, if no altitude is specified, a constant altitude will be assumed for all successive UTM points on the flight path of a target. A local target set may consist of 1 to 99 individual targets.

An ECS OTM exercise using locally defined target sets enables the training officer

to customize an exercise to the FU's site. This site-relevant training uses tactical data bases which depict the geographic environment of an actual FU site. OTM generated exercises can be used in either the stand-alone (ECS) or netted (ICC-ECS) configuration.

Local target set capabilities which the OTM provides include—

- Specific target starting times or random delays added to their starting times.
- Target speed and heading designations.
- The use of ECM by hostile aircraft.
- Identification, friend or foe responses.
- Variable target altitude.
- Control keyboard or graphical input of flight path UTM positions.

Live air trainer. The live air trainer (LAT) is a version of the tactical software, modified to track live targets and simulate their engagement. The training exercise uses the live air trainer software at ECSs and ICCs. The ICC uses a complete FU (RS, ECS, AMG, and LSs), an ICC, and the remaining FUs in the battalion to track and simulate the engagement of live targets in a simulated battalion air battle. ECS operators employ FU AD standing operating procedures (SOPs) during this training exercise.

Terrain mapping trainer. The terrain mapping trainer (TMT) is an ECS embedded trainer software which will be used to train all TACI OSLB-MTM and masked area drawing functions. TMT will provide training using actual line radar-generated terrain data which is recorded by TMT at a site during the radar data map generation process. Subsequent training sessions can be conducted at any site, without radiating, using the previously generated data.

Maintenance Trainers

Patriot batteries use tactical equipment in the maintenance training program. Maintenance training devices and simulators are used

in proponent school training programs but are not available at the Patriot battalion.

Equipment object trainers. Equipment object trainers are used where actual components can be easily and economically removed from tactical equipment and placed in a training configuration. A group of Patriot organizational maintenance trainers has been developed to provide hands-on training for the Patriot fire control section and the ICC. The Patriot organizational maintenance trainer (POMT) can consist of any combination of the following trainers: the active maintenance training simulator (AMTS), the part task trainer (PTT), and the ECS curbside training system. These trainers are active life-size mockups and are physically segmented for efficient student team processing.

The trainers are driven by commercial computers to simulate tactical hardware and maintenance software for realistic hands-on maintenance training. With few minor exceptions, no real tactical hardware or software is used within the POMT. Each simulated shelter and part task trainer contains both active and passive components. The active components are those that support the selected maintenance task to be trained. The passive components are nonfunctional but look like their real hardware counterparts. The system is capable of training 12 maintenance teams, simultaneously and independently.

Active maintenance training simulator. The active maintenance training simulator (AMTS) enables operator and operator maintainer trainees to develop a level of proficiency in the use of display aided and manual maintenance procedures through practice of selected critical maintenance tasks associated with the ECS and RS. The AMTS can present realistic display aided and manual maintenance procedures and procedural cues to an operator maintainer trainee who will direct the accomplishment of remove and replace, repair, fault locate, test, inspect, adjust, align,

and calibrate tasks performed by other operator maintainer trainees at interactive RS and ECS simulators. The conditions realistically simulate actual equipment.

The AMTS consists of the following major subsystems:

- Maintenance control computer with peripherals and instructor control station.
- Computer simulator interface unit (CSIU).
- ECS simulator.
- RS simulator.
- RS reader stations (four).

Part task trainer. The PTT is a portion of the POMT. The PTT provides a realistic training environment for Patriot operator and maintenance personnel. The PTT is capable of simulating repeatable ECS, display and control console, and RS final modulator power supply maintenance training tasks. It provides operator and maintenance trainees with an opportu-

nity to develop levels of proficiency in the use of display aided maintenance tasks associated with specific ECS and RS equipment. It also is capable of providing the missile system technician the means of developing a proficiency in the analysis and solution of problems that are not resolved by operator maintainer personnel. The three display and control console simulators (DCCS) support simulations of fault symptoms and the sequencing of the proper scenarios expected to be performed by the MST trainee to correct a fault.

The PTT consists of the following subassemblies:

- Maintenance control computer.
- Simulator interface controller.
- Instructor station.
- Six reader stations.
- Three display and control console simulators.
- Three final modulator simulators.

TACTICAL EQUIPMENT, WEIGHTS AND DIMENSIONS

Figure B-28, on page B-42, provides approximate weights and dimensions of tactical equipment in the emplacement, march order, and shipping configuration. Tabulated data is given in both English and metric systems.

All weights and dimensions correspond to the equipment configuration shown. Additional and more precise weights and dimensions can be found in the respective equipment TMs, which should be the basis for logistical planning.

UNIT ORGANIZATION

The Patriot battalion consists of a headquarters and headquarters battery and from either three to six firing batteries (FUs) shown in Figure B-29, page B-45.

centrally located in relation to other battalion elements. This enables it to provide responsive and timely support (see Figure B-30, page B-45).

HEADQUARTERS AND HEADQUARTERS BATTERY

The battalion headquarters and headquarters battery (HHB) is both a tactical and administrative organization. It is organized with a battalion headquarters and a headquarters battery. Whenever tactically feasible, the HHB will be

BATTALION HEADQUARTERS

The battalion headquarters provides command, operational control, and administrative and logistical support for the battalion. The functions performed by the Patriot battalion headquarters are similar to those performed in other ADA battalion organizations. The following paragraphs discuss those sections unique to the Patriot battalion.









EQUIPMENT	MAXIMUM WEIGHT	MAXIMUM OVERALL DIMENSION		
		HEIGHT	WIDTH	LENGTH
 LAUNCHING STATION, GUIDED MISSILE, SEMITRAILER MOUNTED, M901	35,848 kg 79,030 lb	3.99 m 13.08 ft	2.87 m 9.42 ft	16.86 m 55.33 ft
 INFORMATION AND COORDINATION CENTRAL, AN/MSQ-116 WITH ELECTRIC POWER UNIT II, PU 789	17,450 kg 38,470 lb	3.61 m 11.83 ft	2.62 m 8.60 ft	14.44 m 47.4 ft
 COMMUNICATIONS RELAY GROUP, AN/MRC-137 WITH ELECTRIC POWER UNIT II PU 789	17707 kg 39,036 lb	3.61 m 11.83 ft	2.54 m 8.32 ft	14.44 m 47.4 ft
 ELECTRIC POWER PLANT III, HEMTT MOUNTED, M977EPP	19,840 kg 43,727 lb	3.32 m 10.9 ft	2.44 m 8.00 ft	9.28 m 30.4 ft
 RADAR SET, SEMITRAILER MOUNTED, AN/MPQ-53	39,645 kg 87,400 lb	3.61 m 11.83 ft	2.87 m 9.42 ft	16.99 m 55.75 ft
 ENGAGEMENT CONTROL STATION, TRUCK MOUNTED, AN/MSQ-104	16,738 kg 36,900 lb	3.61 m 11.83 ft	2.64 m 8.67 ft	9.68 m 31.77 ft
 ANTENNA MAST GROUP, OE-349/MRC	15,976 kg 35,220 lb	3.66 m 12.0 ft	2.44 m 8.0 ft	10.67 m 35.0 ft
 ELECTRIC POWER UNIT II, PU 789	3,121 kg 6,880 lb	2.15 m 7.05 ft	2.44 m 8.0 ft	4.78 m 15.67 ft

Figure B-28. Major items, tactical equipment, weights, and dimensions.





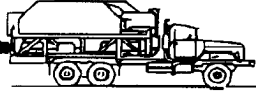

EQUIPMENT	MAXIMUM WEIGHT	MAXIMUM OVERALL DIMENSION		
		HEIGHT	WIDTH	LENGTH
 HEAVY EXPANDED MOBILITY TACTICAL TRUCK (HEMTT) 10-TON, M983	14,606 kg 32,200 lb	2.85 m 9.3 ft	2.44 m 8.0 ft	8.9 m 29.25
 M-92 TRUCK	12,588 kg 27,749 lb	2.95 m 9.67 ft	2.49 m 8.17 ft	9.68 m 31.77 ft
 RADAR SET	10,124 m 22,320 lb	2.51 m 8.25 ft	2.87 m 9.42 ft	6.66 m 21.9 ft
 ENGAGEMENT CONTROL STATION	5265 m 11,600 lb	2.22 m 7.28 lb	2.62 m 8.6 ft	6.40 m 19.35 ft
 INFORMATION AND COORDINATION CENTRAL	5,235 kg 11,540 lb	2.22 m 7.28 ft	2.62 m 8.6 ft	5.90 m 19.35 ft
 ANTENNA MAST GROUP	6,486 kg 14,300 lb	2.44 m 8.0 ft	2.44 m 8.0 ft	6.71 m 22.0 ft
 COMMUNICATIONS RELAY GROUP	41,124 kg 9,106 lb	2.22 m 7.28 ft	2.47 m 8.1 ft	5.90 m 19.35 ft
 MISSILE ROUND, MIM-104	1,701 KG 3,750 LB	1.00 m 3.27 ft	1.07 m 3.52 ft	6.10 m 20.0 ft

Figure B-28. Major items, tactical equipment, weights, and dimensions (continued).



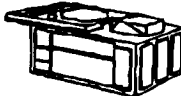
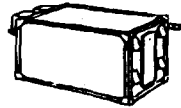

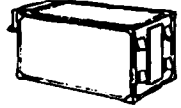
EQUIPMENT	MAXIMUM WEIGHT	MAXIMUM OVERALL DIMENSION		
		HEIGHT	WIDTH	LENGTH
 MISSILE	907.2 kg	SPAN	DIAMETER	6.10 m
	2,000 lb	.87 m	.41 m	
 CANISTER	793.8 kg	HEIGHT	WIDTH	6.10 m
	1,750 lb	1.00 m	1.07 m	
 MAINTENANCE CENTER (MC)	18,514.6 kg	3.5 m	2.46 m	14.14 m
	40,817 lb	11.0 ft	8.08 ft	46.4 ft
 SMALL REPAIR PARTS TRANSPORTER (SRPT)	18,514.6 kg	3.35 m	2.46 m	14.14 m
	40,817 lb	11.0 ft	8.08 ft	46.4 ft
 GUIDED MISSILE TRANSPORTER (GMT) WITH 4 GMs	25,465 kg	3.67 m	2.54 m	10.68 m
	56,140 lb	12.3 lb	8.33 ft	35.04 ft
 LARGE REPAIR PARTS TRANSPORTER (LRPT)	17,172 kg	2.85 m	2.44 m	10.19 m
	37,857 lb	9.33 ft	8.0 ft	33.42 ft

Figure B-28. Major items, tactical equipment, weights, and dimensions (continued).

Command Section

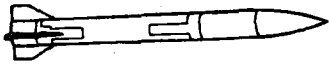
The battalion commander, the executive officer, and the coordinating and special staff officers make up the command section. Coordinating staff officers are the S1, S2, S3, and S4. Special staff officers are the chaplain, surgeon, communications-electronics officer, and the ADA coordination officer. The command section also includes the battalion command sergeant major, the

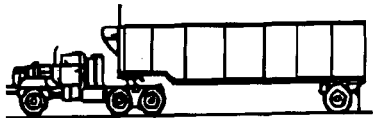
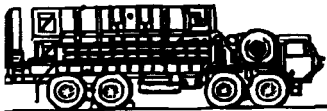
battalion signal officer, and three radio operators. (See FM 101-5 for detailed information on staff elements.)

Fire Distribution Center

The FDC operates the ICC which is the battalion fire direction center (FDC). The FDC exercises direct control and supervision of Patriot FUs and attached or assigned

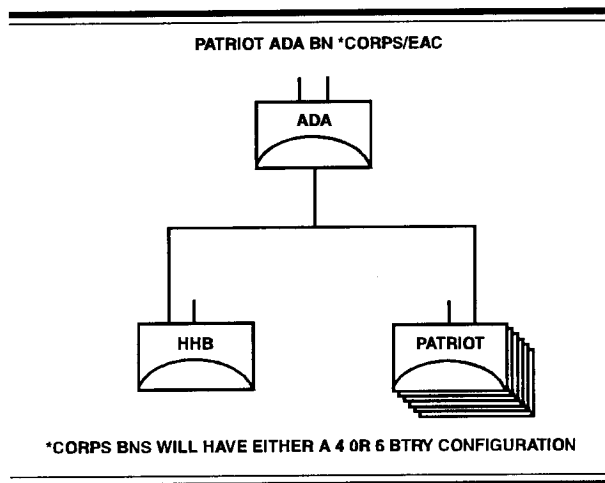

Figure B-29. Battalion organization chart.

Hawk AFPs during the air battle. The ICC exchanges data and voice information with the brigade TOC, each FU, and adjacent Patriot or Hawk battalions. If the brigade TOC is out of action, the ICC can establish

data link communications directly with the control and reporting center (CRC).

Communications Platoon

The communications platoon includes a platoon headquarters, a communications center section, and a relay section. The communications center section is responsible for battalion wire communications operations and operation and maintenance of the battalion radio sets. It also handles administration of COMSEC material and organizational maintenance of HHB communications equipment (less multichannel). The communications relay section operates four communications relay groups (CRGs). The CRGs provide UHF (voice and data) and VHF communications to units not having line of sight with the battalion FDC. Each communications relay group has a crew of four.

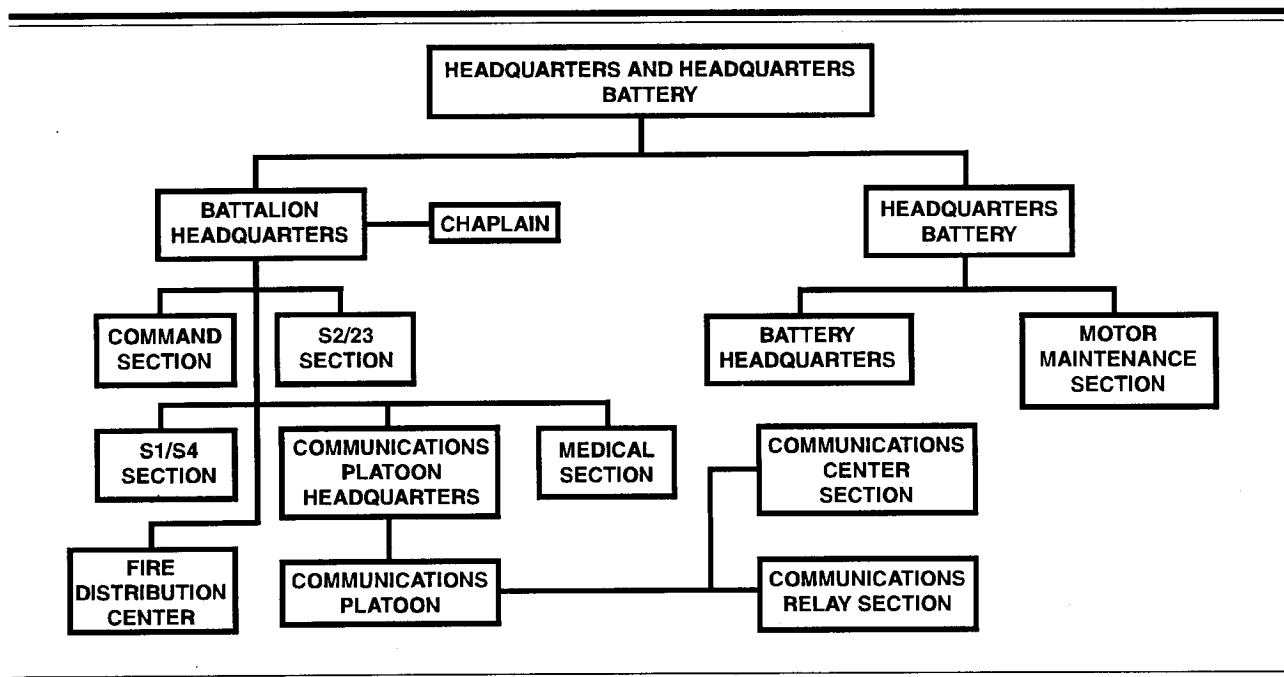

Figure B-30. HHB battery organization chart.

HEADQUARTERS BATTERY

Headquarters battery supports the battalion. It provides the resources to support battalion headquarters personnel with food service and unit supply. It provides refueling and unit maintenance support for vehicles, power generators, and engineer missile equipment. Headquarters battery is organized with a battery headquarters section and a motor maintenance section. The headquarters has two dedicated MANPADS teams and equipment to provide self-defense of the FDC.

FIRE UNIT

Each Patriot FU includes a battery headquarters; a fire control platoon, a launcher platoon, and a maintenance platoon. Two

dedicated MANPADS teams and equipment are authorized to provide coverage in radar blind areas during malfunctions, march order, and emplacement.

Battery Headquarters

A battery headquarters section provides command, unit administration, unit supply, and food service functions. Figure B-31 illustrates the organization of a Patriot battery.

Fire Control Platoon

The fire control platoon includes a platoon headquarters and a fire control section. The platoon is capable of sustained operations and is fully mobile. Fire control

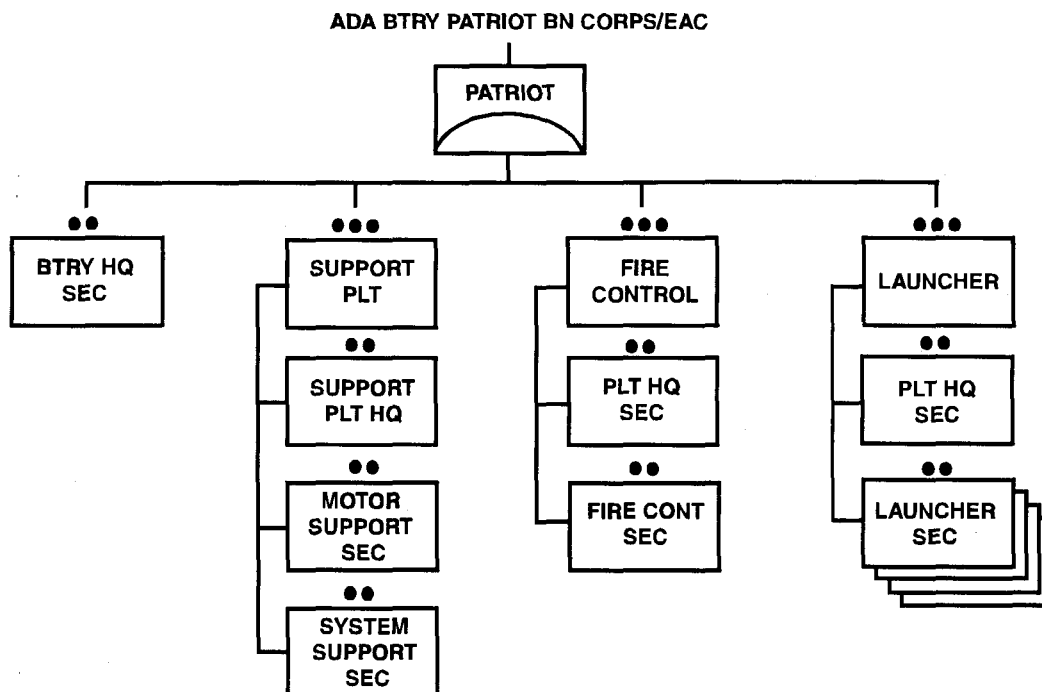

Figure B-31. Patriot battery organization chart.

section equipment includes the ECS, RS, EPP, and the AMG. The UHF multichannel communications are installed and operated by a three-man team. The platoon has personnel to operate the EPP and perform diesel maintenance. Two dedicated MANPADS teams and equipment are authorized and assigned to the fire control platoon to provide self-defense of the battery.

Launcher Platoon

The launcher platoon contains four launcher sections. Each section has two launching stations. Each launching station is manned by three crew members.

Support Platoon

Effective communications, reliable transportation, and system maintenance are

essential to the FU's mission. A support (maintenance) platoon has been organized to fill these needs. It consists of a support platoon headquarters, motor support section, and system support section. The support platoon headquarters exercises C² over the support platoon. The platoon leader and platoon sergeant ensure that PMCS are performed in a timely and coordinated manner. The motor support section provides organizational maintenance for all organic vehicles and generators, vehicle recovery, and refueling. The section maintains a PLL for motor support. The system support section performs organizational maintenance for Patriot system-peculiar equipment—ECS, RS, LS, AMG, electronics, and maintenance test equipment.

APPENDIX C

IPB IN SUPPORT OF AIR DEFENSE OPERATIONS

Conducting a well-planned IPB is fundamental to the execution of the ADA mission. It is essential that the Patriot battalion and battery commanders be able to understand enemy air and ground operations and how the terrain will affect enemy operations. By evaluating this information, various possible enemy COAs can be developed and war-gamed. This will provide commanders, at all levels, a better picture of the battlefield and enable them to plan and place assets to obtain maximum firepower in the right place at the right time.

IPB in support of AD operations is a quantified, step-by-step process that examines enemy air and ground activity, and identifies gaps in intelligence holdings. This process will allow the commander and his staff to direct his collection assets to enable them to visualize the battlefield and understand the enemy's intentions. Preparation and continuous updates of aerial IPB are fundamental to the execution of the AD mission on the modern battlefield.

THE IPB PROCESS

The breakup of the former Soviet Union has caused the Army to shift its focus from Soviet doctrine to other regional threats. With the current lack of doctrine to plan against, the IPB process will provide continuous input toward building that doctrine.

FM 34-130 is the manual that explains the IPB process. This appendix will describe the process as it applies to Patriot operations. IPB allows the commander and the intelligence staff to predict where and when the enemy will strike, and what assets he will use. The modern battlefield is viewed in three dimensions: width, depth, and airspace. This airspace, or aerial dimension, is the most dynamic and fast paced of the three dimensions. The Patriot battalion and battery commanders must consider all the aspects of air operations and must be aware of the capabilities

of all air threats, to include ballistic and aerodynamic (cruise) missiles; multimission UAVs; and RW and FW aircraft. The S2 should rely heavily on input from the air defense and aviation officers while integrating air aspects into the IPB process.

The IPB process has four steps:

- Define the battlefield environment.
- Describe the battlefield effects.
- Evaluate the threat.
- Determine threat COAs.

As air IPB is conducted from a different perspective than that of ground IPB, the terrain and weather have correspondingly different effects on air operations. The primary air threats that Patriot commanders must carefully evaluate are: TBMs, CMs, and FW aircraft. Secondary consideration must be given to UAVs and RW aircraft.

DEFINE THE AIR BATTLEFIELD ENVIRONMENT

The air battlefield, like the ground, includes an AO, battle space, and an area of interest (AI).

The air AO is the area where the commander is assigned responsibility and authority for military operations. It is identical to the ground in width and depth, and extends vertically up to the maximum altitude of threat aircraft and missile systems.

Battle space is a physical volume that expands or contracts in relation to the ability to find and engage the enemy. It includes the breadth, depth, and height in which the commander positions and moves assets over time. Battle space is not assigned by a higher commander and can extend beyond the commander's AO.

The AI is the geographic area from which information and intelligence are required to facilitate planning or successful conduct of the command's operation. Because the commander and staff need time to process information and to plan and synchronize operations, the commander's AI is generally larger than the AO or battle space. Due to the great distances that aircraft and missiles can rapidly cover, the air AI will extend vertically and horizontally to cover the maximum service ceilings and ranges of threat air systems. These include missile and delivery systems, plus known or suspected threat airfields, forward arming and refueling points (FARPs), and missile sites.

DESCRIBE THE BATTLEFIELD EFFECTS (TERRAIN/WEATHER ANALYSIS)

The nature of airspace does not eliminate the need for terrain analysis. Air IPB focuses on the impact of geographic factors on the ability of threat air to approach, find, and engage a target. Analysis of the terrain for air IPB follows the same principles as ground analysis, and uses the military aspects of terrain.

OBSERVATION AND FIELDS OF FIRE

This relates to the influence of terrain on reconnaissance and target acquisition. In the IPB context, observation relates to optical and electronic line-of-sight (LOS). Many air and battlefield operating systems require LOS to effectively find and engage targets. These systems include radios, radars, jammers, direct-fire weapons, and airborne-ground observers. Fields of fire relate to the terrain effects on weapon systems. Battlefield airspace must be analyzed with regard to routes which provide the best protection

for air threats entering the target area, and those which provide the best fields of fire once they reach the target area.

COVER AND CONCEALMENT (MASKING)

Cover and concealment have slightly different applications with respect to air systems. There are several tactics and techniques which fall into the context of cover and concealment and are defined as follows:

- Contour flying—to maintain a constant low altitude from the ground with regard to the terrain.
- Pop-up tactics—using natural terrain or man-made features to conceal the attacker until the last possible moment before engaging a target.
- Masking—using terrain to protect an air system from visual and or electronic observation or detection.
- Cover—using terrain to provide protection from direct fire weapon systems.

- Ground clutter—can be characterized as a reduction of signal to noise ratio due to the signature of a background and is different for each type of terrain and feature. Threat air systems will use contour flying, masking, and ground clutter to avoid detection and to provide cover from direct fires. Air systems will also use the terrain by loitering on reverse slopes, using pop-up tactics, and by using ground clutter and vegetation as a backdrop to enhance concealment.

OBSTACLES

Obstacles are broken down into three primary types:

- Those which prevent the effective employment of AD systems.
- Those which restrict contour flights (below 22.8 meters).
- Those which force air threats to employ a particular attack profile or route, or to gain excessive altitude.

Of particular interest are obstacles and terrain which restrict lateral movement within an AA and movement corridor; canalizing movement or restricting evasive action. Additionally, terrain may stop the employment of certain air threat systems in that it exceeds the system's maximum operating ceiling.

KEY TERRAIN

Key terrain is any locality or area in which the control will afford a marked tactical advantage to either combatant. In air analysis, this consists of terrain features which canalize or constrain air threat systems, plus terrain with an elevation higher than the maximum ceiling of air threat systems. Additionally, areas that can be used for airfields, LZ/DZs, or FARPs need to be considered as key terrain, since these areas could be used to support friendly or threat air

operations that may be targeted against the Patriot site or the defended asset.

AIR AVENUES OF APPROACH

Air avenues of approach (AAOAs) are evaluated using some of the same criteria as for ground. A good AAOA into its target area will permit maneuver while providing terrain masking from surface-to-air weapon systems. A twisted arrow will be used to denote AAOAs. Red arrows will represent threat avenues and blue will represent friendly avenues. Ensure that each AAOA is numbered.

Some common AAOAs are—

- A road running down a valley.
- A direct line from the enemy operating base.

- A river bed.

Factors which should be used to determine AAOAs are—

- Type of air threat.
- Air threat point of origin.
- Potential to support maneuver.
- Freedom to maneuver within the air avenue.
- Protection afforded to the air threat system.
- Air threat and pilot capabilities.

TYPES OF AIR THREATS

The different types of air threats and their flying characteristics are as follows:

- Some CMs are terrain-following. TBMs are not terrain-dependent.

- FW aircraft usually follow major terrain and man-made features (rivers and roads). Depending on doctrine, they may fly a straight line.

- UAVs, small and elusive, usually fly low. The altitude can vary.

- RW aircraft primarily conduct contour flights. They follow ridge lines and military crests.

AIR THREAT POINT OF ORIGIN

Always begin at the threat operating base (airstrip and launch sites) and work toward what you believe is the enemy objective. This allows a look at the big picture. When determining air avenues, do not stop at the edge of the commander's battle space. An air avenue may look good on the map, but there could be a mountain or an urban area which could discourage the use of that avenue.

Air avenues support maneuver and are used to achieve ground objectives or to support theater and national objectives. Air avenues also provide freedom to maneuver while using air assets. Does the avenue—

- Canalize the air system?
- Provide observation and fields of fire?
- Provide LOS?
- Have access to adjacent avenues?
- Provide the ability to find a target and

use available munitions (a good ordnance release line)?

Air avenues provide protection for the air system and pilot. Does the avenue provide—

- Terrain masking (cover and concealment)?
- For the full use of air speed?
- Protection against radar detection?
- Protection from AD weapon systems

and tactical air support?

- For limited exposure to surface weapons?

Do the air system and pilot have the capabilities to perform contour flying at night, in all weather conditions and ranges?

WEATHER ANALYSIS

Air operations are especially susceptible to the effects of weather. Weather analysis for air operations considers the same factors as ground operations. These factors are—

- Visibility. Visibility has a significant impact on air operations, reconnaissance, surveillance, and target acquisition.
 - High winds. High winds will hinder maneuver, CAS, and target engagement, especially in tight mobility corridors.
 - Precipitation. Precipitation affects air system performance and reduces the effectiveness of radars.
 - Cloud cover and ceilings. Clouds may restrict operations by setting low operational ceilings and restricting visibility and target engagement.
 - Extreme temperatures and humidity. Temperature has a severe effect on air systems by decreasing combat range and altitude (particularly RW aircraft).

EVALUATE THE AIR THREAT

Threat evaluation for air IPB consists of a detailed study of enemy air capabilities, organization, and doctrine. The following steps should be used when evaluating the threat:

- Collect and analyze doctrinal threat data.
- Analyze threat air capabilities.
- Conduct target evaluation.
- Update and analyze threat operations.

THREAT DATA

Collecting and analyzing doctrinal threat data should determine the following:

- The major strategic, operational, and

tactical objectives of the enemy's air operations.

- Which objectives may be targeted for destruction or suppression.
 - Where friendly AD assets fit into the enemy's objectives. Do they need to be destroyed or suppressed for the enemy plan to work?
 - The enemy's air order of battle. How are his assets organized? Knowledge of threat organization, and who has operational control, will indicate the importance of the AO. For example, if the enemy's SU-24s are at theater level

and you are seeing SU-24s in your area, then you are probably receiving the theater's main attack.

- How does the enemy doctrinally attack? Will the enemy use airborne-air assault forces with an air or ground attack? Will they synchronize the air attack? Do they have the capability to coordinate an air strike (possibly with varied air threat platforms that can overmatch friendly AD capability)?

- Air system entry (ingress) and exit (egress) speeds.
- What is the size of the threat's TBM brigade, battalion, or battery, and what is their operational doctrine for employment?
- How will UAVs be used (for example BDA, RISTA, or attack)? What are the associated profiles?

- Launch points for TBM and UAVs. What are the likely targets? What is the range and endurance of these systems?

- Doctrinal distances for forward arming and refueling points. If the enemy's maximum range falls short of your AO, template where the enemy is likely to stop and refuel.

- CAS. What is the enemy's capability to coordinate air-to-ground attacks?

- BAI. How and where will the enemy attack ground targets?

- SEAD. What is the enemy's capability to coordinate air and artillery operations?

- Flight profile. At what altitude will the enemy approach the target, deliver munitions, and exit the target area?

- Release authority of certain types of ordnance. This is particularly important when dealing with NBC threats.

THREAT AIR CAPABILITIES

Analyzing threat air capabilities should determine the capabilities of the threat systems in terms of—

- Ability to deliver weapons of mass destruction.

- Performance (speed, altitude, airfield restrictions, and troop-weapon load capacity).

- Endurance and range of UAVs: ingress and egress altitudes and speeds.

- Levels of combat readiness.

- Ability of RW aircraft to conduct pop-up maneuvers and determine the standoff range for firing ATGMs and rockets.

- Target acquisition (visual, radar, and laser guided), night capability, acquisition and identification ranges.

- Standoff ranges for aerodynamic (cruise and tactical air-to-surface) missiles.

- Ordnance load (maximum weight, type, and load mixture).

- Personnel load.

- Navigational capability (type of radar; can it fly at night or in adverse conditions?).

- Combat radius (with or without external tanks, ordnance, location of staging bases).

- Loiter time (how long will it have on station over the target area?).

The Countermeasures Environment

These include standoff jammers, ground-based jammers, or reconnaissance/chaff-laying UAVs or aircraft. Will these degrade friendly AD systems? Does the enemy have antiradiation missiles?

Pilot Training

Can pilots fly at night or perform contour flying? During peacetime did pilots conduct the type of mission they are expected to conduct during war? What are the types and capabilities of threat ordnance? Each type of ordnance should be evaluated for the following:

- Range—assume engagement at maximum range and two-thirds maximum range.

What is the accuracy?

- Release altitude—how high or low must the aircraft fly?
- Number of missiles available—what is the reload-refire time?
- Warhead type—for example, NBC, HE, submunitions, et cetera. What are release altitudes?
- Guidance modes—how does the pilot find and engage? (For example, wire-guided, TV, fire-and-forget, or laser beam rider.)

TARGET VALUE EVALUATION

Target value evaluation should determine what targets are to be labeled as high-value targets (HVTs). HVTs are assets the enemy or friendly commander has deemed as important for the successful accomplishment of his

DETERMINE AIR THREAT COURSES OF ACTION

Determining air threat COAs, as with ground, relates the enemy's air, counterair, air defense, and airborne and air assault doctrines with the effects of weather and terrain to determine how the enemy will employ their assets. This is accomplished through the development of the situation, event, and decision support templates. The process of developing these templates is covered in FM 34-130.

SITUATION TEMPLATE

The situation template integrates air attack profiles with terrain, focusing on specific air avenues of approach or mobility corridors. This is done to determine which avenues are the most capable of supporting specific attack techniques, profiles, or the most direct routes to DZ and LZs to ensure survivability.

EVENT TEMPLATE

The event template depicts points (NAIs) where you expect to see certain activities of

mission. HVTs are determined by operational necessity and weapon system capability.

UPDATE AND ANALYZE THREAT OPERATIONS

It is important to continuously update air threat operational data (for example, known launch sites, targets, and launching and firing times) to present a clear picture of the current threat situation. Current threat operational data will need to be analyzed against historical data so a pattern of locations for operating bases or launch areas can be determined. Analyzing missile impact area and firing times will give indicators if threat force operations and objectives. Once threat locations, operations, and objectives are understood, steps can be taken to defeat the enemy by readjusting target planning or relocating Patriot assets.

tactical significance and is used to confirm or deny an enemy COA. In air IPB, these NAIs are based on the terrain constraints on air approach routes to potential targets and analysis of the enemy's attack profiles. Examples of NAIs include DZ and LZs, FARPs, forward staging areas, and aerial choke points.

DECISION SUPPORT TEMPLATE

The decision support template (DST) is based on the situation and event templates. The DST does not dictate decisions to the commander, but rather identifies when and where decisions may be required. It is a graphic picture of the intelligence estimate combined with the operation plan and should depict—

- AAOAs.
- DZ and LZs.
- Ranges of enemy systems.
- Ranges of friendly AD systems.
- Target areas of interest (TAIs).

- Decision points (DPs).
Air TAIs and DPs are determined in the same manner as ground operation. However,

due to the high speeds of air systems, DPs must be placed significantly farther in advance of the TAIs.

APPENDIX D

BATTLE BOOKS

Battle books are used to establish the detailed layout for each position that a unit occupies or may occupy. A preplanned position should have a battle book established for it even though the unit may never occupy it. Battle books enable the unit to occupy a position quickly, efficiently, and with the minimum amount of difficulty. RSOP OICs are responsible for ensuring their completion.

OBJECTIVES

The objective is to develop battle books on all suitable Patriot sites within a given AI. This alleviates some of the intangibles associated with selecting locations for follow-on moves. Also, use of battle books by the RSOP OIC

speeds up RSOP procedures and facilitates the battery's occupation of a new position. In essence, battle books are a key ingredient in maximizing agility on the battlefield.

PREPARATION

The preparation of battle books implements the planning process with emphasis on IPB. The selection of positions which Patriot units can occupy starts with the S2 and the evaluation of the enemy's possible avenues of approach and COAs. The S2 and S3 will then select possible positions to be occupied. The RSOP OIC will finalize the battle book preparation by performing the RSOP actions necessary to complete his task. These actions should be performed under the guise of other than tactical operation. Battle books normally contain the following information:

- Reconnaissance data form (general).
- Reconnaissance data form (equipment layout).

- Reconnaissance data form (defense plan).
- Reconnaissance data form (threat).
- Reconnaissance data form (assembly area if applicable).
- Reconnaissance data form (communications).
- Primary and secondary routes of march (driver's strip maps).
- Coverage diagram.
- Clutter diagram (if applicable).
- 1:50,000 map of area(s).
- Strip maps to all supply points (primary and alternate routes).

Some examples of reconnaissance forms are found in the following pages.

UNIT: HHB 1st Bn 7th ADA

LOCATION: FQ 545825

PTL NA STL 1 NA STL 2 NA STL 3 NA

RESUPPLY POINTS LOCATION

CLASS I FQ861862

CLASS II FQ639812

CLASS III FQ628825

CLASS IV FQ598839

CLASS V FQ665821

CLASS VI FQ583854

CLASS VII FQ588863

CLASS VIII FQ584856

CLASS IX FQ588866

NEAREST PHONE LOCATION FQ541832

HOSPITAL LOCATION FQ578868

LOCATION OF CIVILIAN

AUTHORITIES FQ643818 (Jolon City Mayor) PHONE 385-2688

CIVILIAN RESUPPLY/ASSISTANCE AVAILABLE

TYPE
Post Office
Alamo airstrip
St. Luke's Church

LOCATION
FQ643818
FQ636809
FQ645821

Figure D-1. Sample completed reconnaissance data form (general).

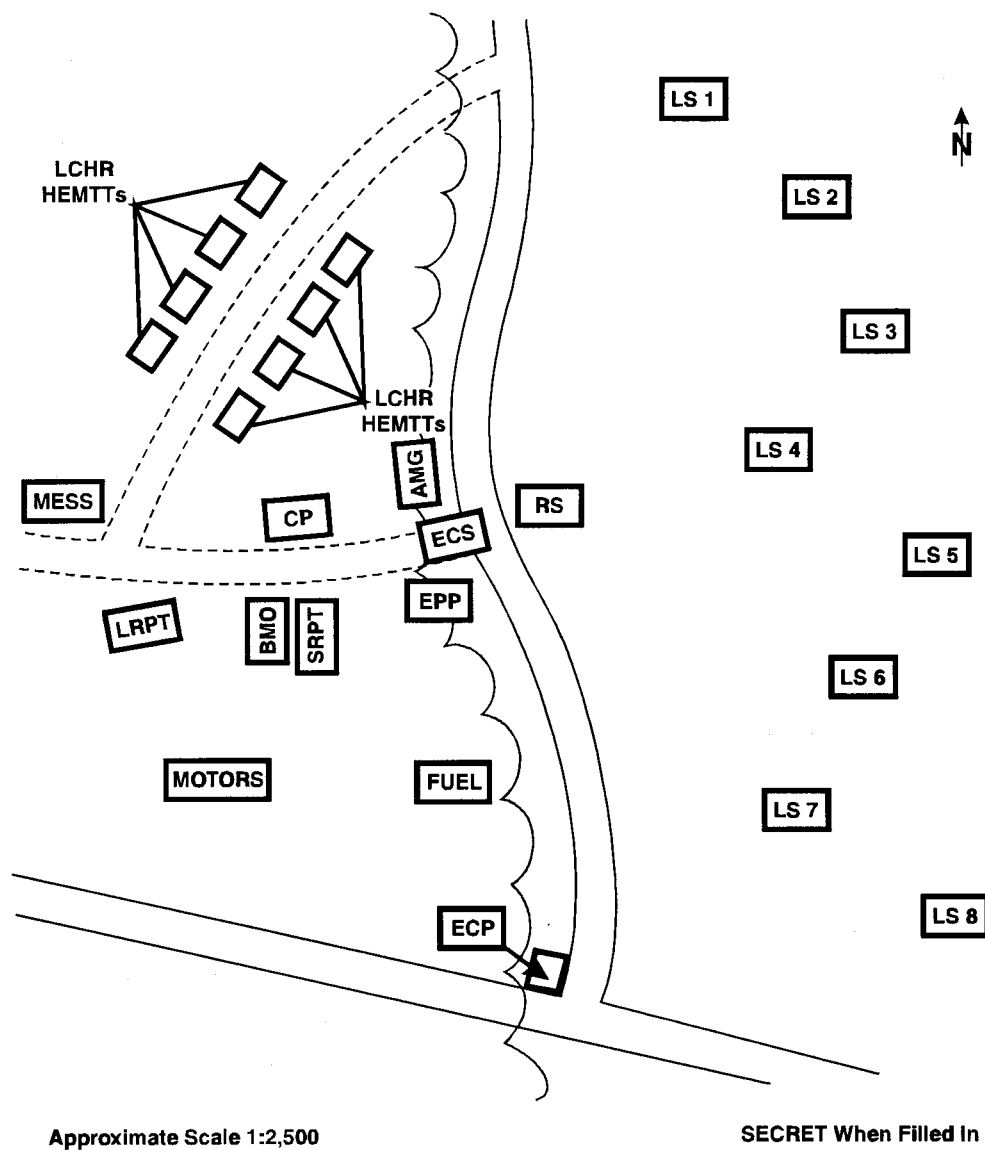
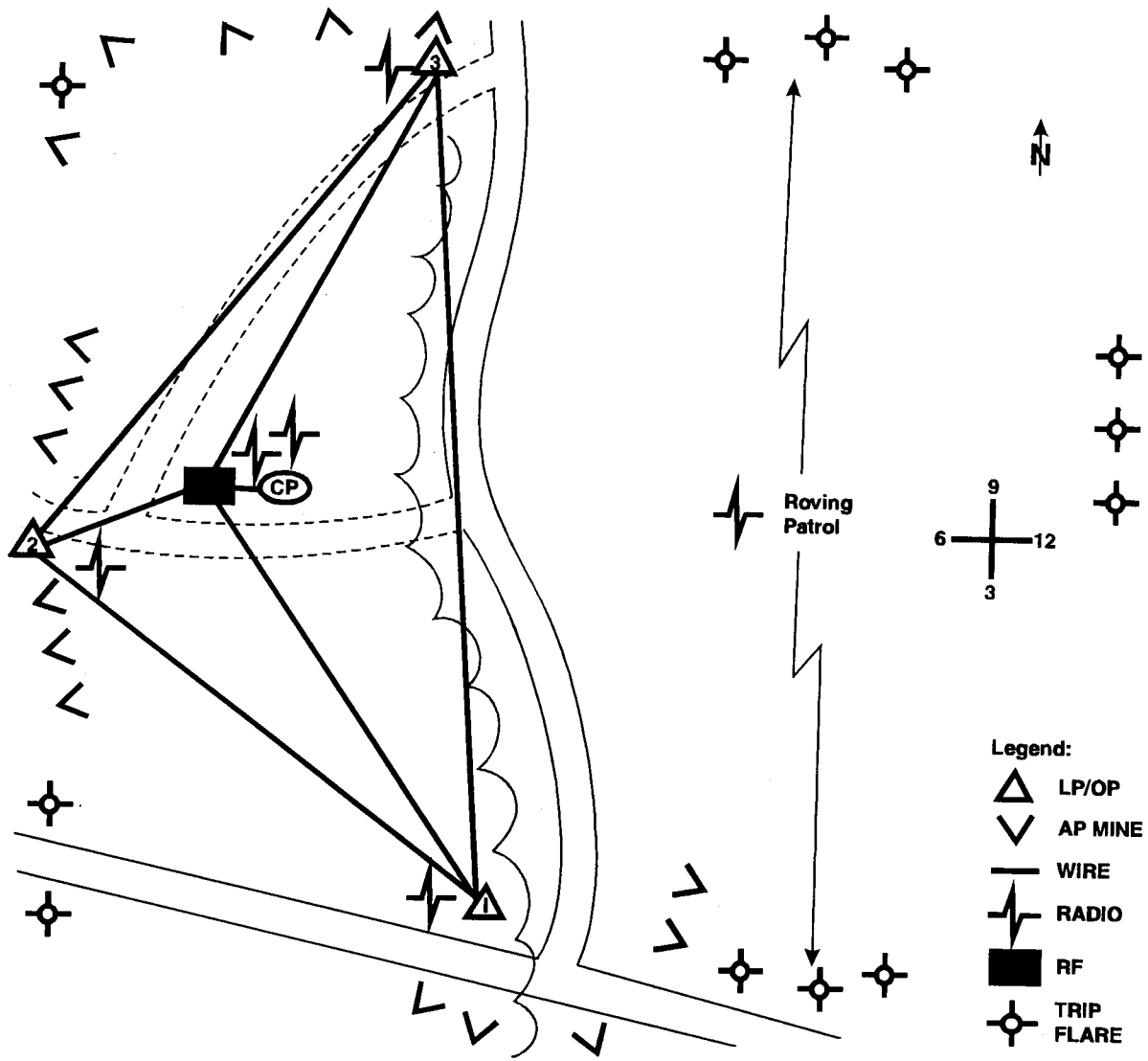

Figure D-2. Sample reconnaissance data form (equipment layout).



Approximate Scale 1:2,500

SECRET When Filled In

Figure D-3. Sample reconnaissance data form (defense plan).

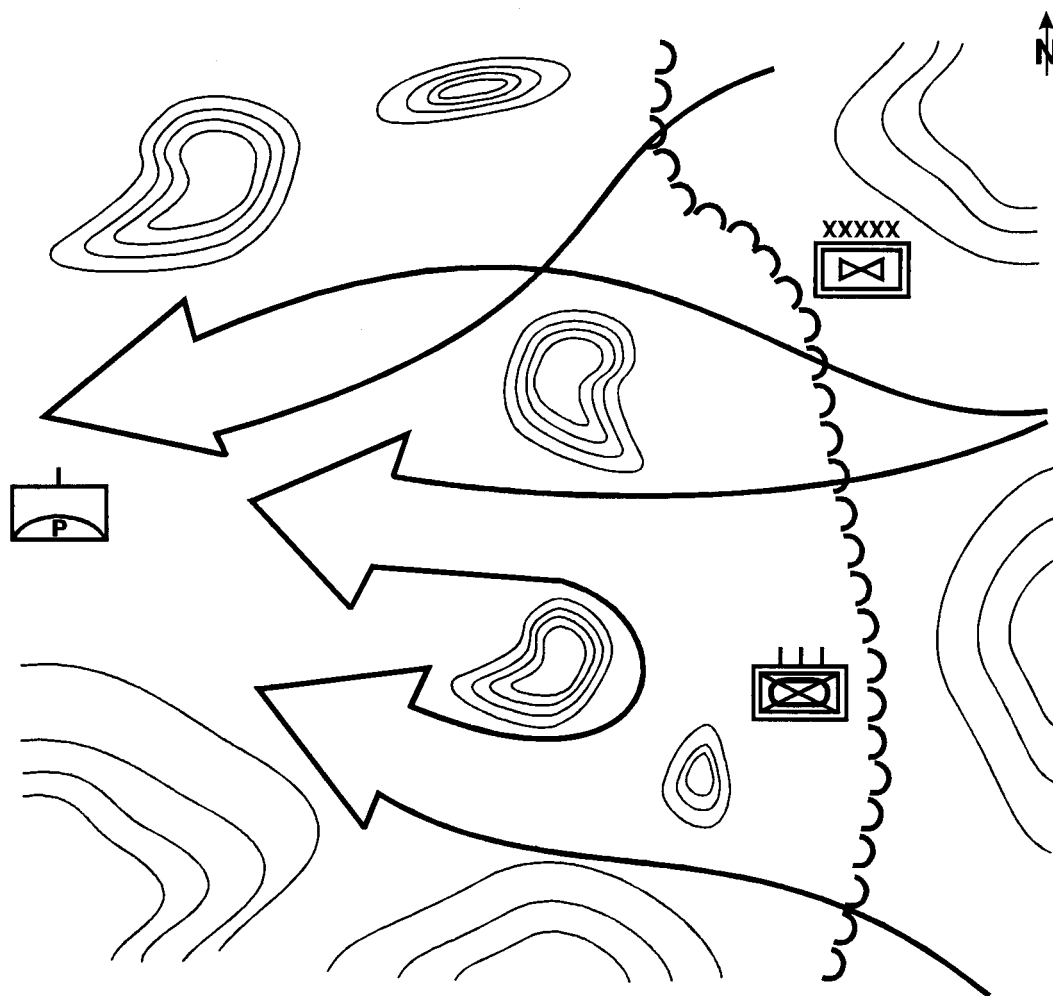

Approximate Scale 1:50,000

SECRET When Filled In

Figure D-4. Sample reconnaissance data form (threat).

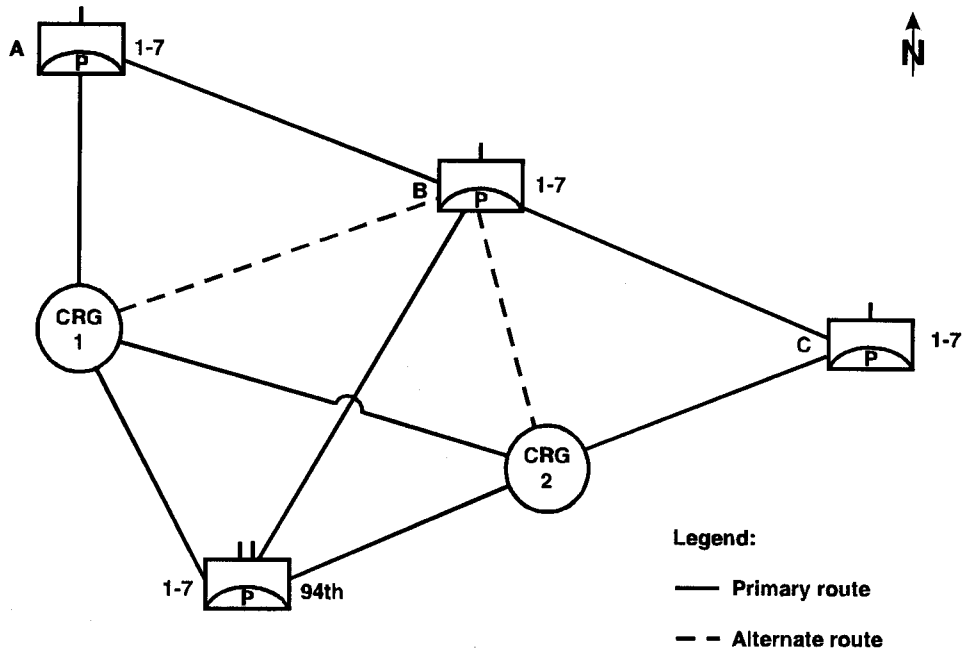

Figure D-5. Sample reconnaissance data form (communications).

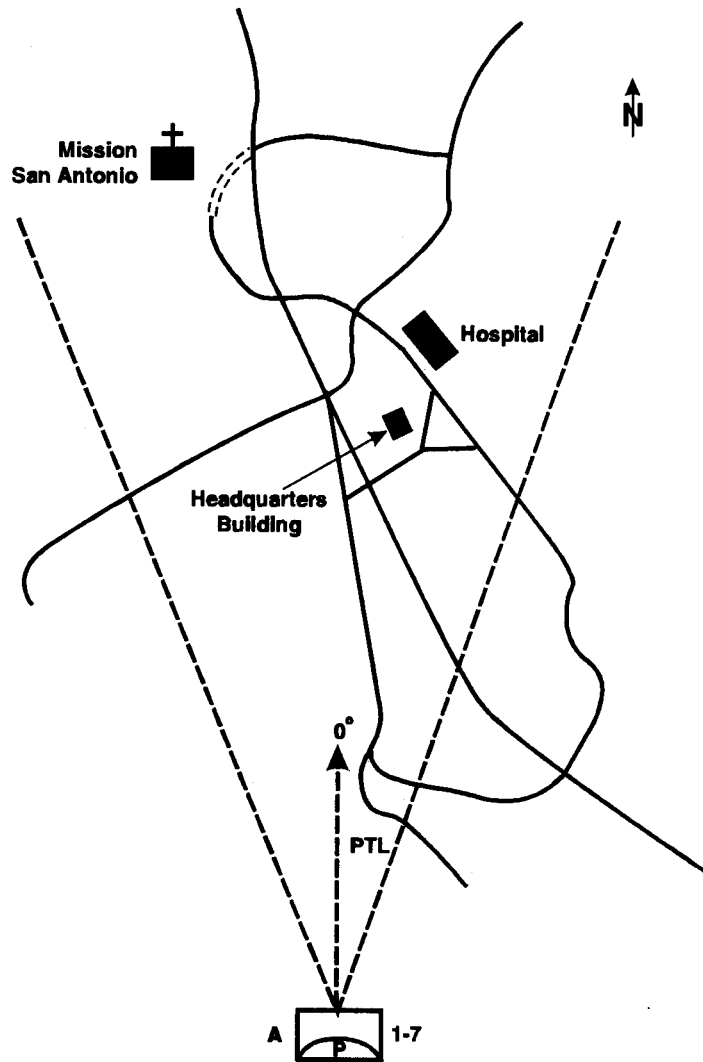
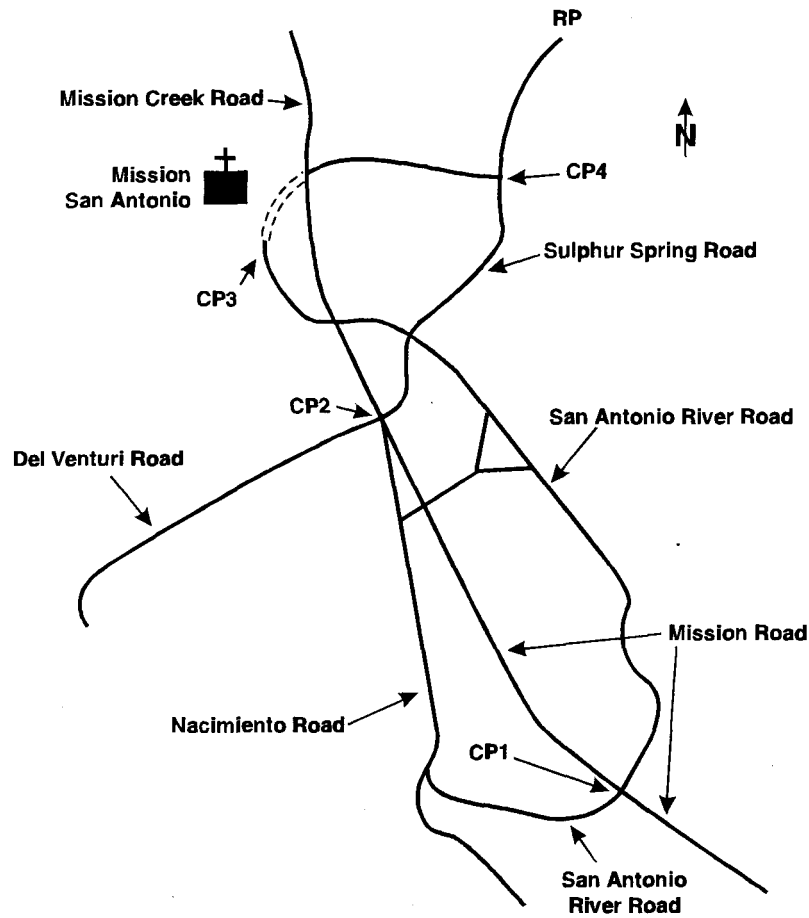

Figure D-6. Battery coverage diagram.



PRIMARY

1. Mission Road to Sulphur Spring Road.
2. North on Sulphur Spring Road to RP.

ALTERNATE

1. Mission Road to San Antonio River Road.
2. Left on San Antonio River Road to Nacimlento Road.
3. Right on Nacimlento Road to Mission Road.
4. Left on Mission Road to Mission San Antonio.
5. Take Mission Road to Mission San Antonio dirt road.
6. At Mission San Antonio dirt road, to hard top, to Sulphur Spring Road.
7. Left on Sulphur Spring Road to RP.

CHECK POINTS (CPs)

1. Mission Road and San Antonio River Road.
2. Del Venturi Road, Sulphur Spring Road, and Mission Road intersection.
3. Mission San Antonio dirt road.
4. Sulphur Spring Road "T" intersection with San Antonio River Road.

Figure D-7. Strip map to supply points.

APPENDIX E

RAIL/SEA/HIGHWAY/AIR TRANSPORTABILITY

The Patriot system is capable of rapid deployment and tactical movement. It is capable of withstanding, without damage, normal movement by rail, sea, highway, or air as well as off-road movement and subsequent operations. All system vehicles have the capability of transport on railway systems conforming to the Passé-Partout International (PPI) loading gauge. The system can be transported in cargo ships and landing craft of the LCM-8 class. The system is deliverable by heavy transport C-141 and C-5A aircraft, and palletized loads are compatible with the USAF 463-L loading system. Vehicles with payloads can be reduced to not-greater-than 142 inches in height in the self-propelled travel configuration to permit unrestricted movement on worldwide highways and bridges. The equipment has built-in waterproofing to permit shallow fording in fresh or salt water to a depth of 30 inches under normal field travel conditions.

TRANSPORTABILITY REQUIREMENTS DATA

Transportability requirements for the Patriot missile system are defined in the materiel needs document and in the system development specifications. Generally, the system with its support elements must be capable of rapid deployment and tactical movement without damage, when moved by

rail, water, highway (including off-road), and air modes.

All vehicles and other appropriate components, shipped crated or uncrated, incorporate lifting and tie-down features per MIL-STD-209. Specific requirements for transportability are listed in the following paragraphs.

RAIL TRANSPORT

Patriot is capable of movement on the PPI loading gauge. Separation of tractors and trailers is acceptable for clearance of the PPI gauge requirement. Rail transport of military equipment on the railway network of Belgium, Denmark, France, Germany, Italy, Luxemburg, and the Netherlands is regulated by STANAGs 2832 and 2175. In NATO countries, Patriot components and vehicles, when dismounted and shipped as separate loads, will clear the

PPI gauge. Therefore, these items would be categorized as ordinary transport equipment, requiring only a load study to select appropriate flatcars and determining shipping procedures. In the road march configuration, however, most Patriot major items fail to clear the PPI gauge. Accordingly, movement will be categorized as exceptional transport, requiring a load study and a traffic study to develop Patriot's routing maps through Europe. Advanced rail planning

and routing must be coordinated and verified by individual host nations before USAREUR

deployment. This is a USAREUR responsibility.

SEA TRANSPORT

Transport aboard cargo ships and landing craft of the LCM-8 class is possible. Tractors and trailers may be separated; however, off-loading of equipment modules is not acceptable for movement aboard the LCM-8 in view of the requirement that the equipment be landed in a service-ready condition. No problems are anticipated in transporting Patriot by the marine mode. Patriot items are readily transportable by break-bulk ships, barge carriers (LASH and Seabee) and roll-on/roll-off (RO/RO) ships. Although Patriot's

major items are not self-contained, most can be loaded on special flatrack containers if transport by containerships is necessary. Patriot can be transported in the logistics over-the-shore (LOTS) environment, provided the system components are dismounted from the transporter vehicles, as necessary, to achieve compatibility with Army barges. Patriot is readily transportable, as required, by LCM-8 provided the M983 is disengaged from the M860A1 semitrailer and transported separately.

HIGHWAY TRANSPORTABILITY

Patriot vehicles must be reduced to a height of less than 142 inches in the self-propelled travel configuration to allow unrestricted movement on worldwide highways and bridges. Off-loading of the GMs is acceptable to meet this requirement. For example, for highway movement in USAREUR, all Patriot vehicles will exceed width allowances. The M983/860A1 tractor-semi-trailer used to transport the RS and LS will also

exceed length limits. The amount of excess, however, is not significant. A movement credit (clearance) will be needed from the transportation movement officer (TMO) at the movement origin. He will accomplish necessary coordination with German or other host nation authorities. Hence, highway movement of the Patriot system can be expedited through advance transportation planning.

GUIDED MISSILE TRANSPORTABILITY

The GM can be transported by standard wheeled vehicles, rail, air (including helicopter, externally and internally loaded), and ship transporters. The GM is transportable

off-road for extended distances on the LS or tactical vehicles. Transport of the GM will be according to AMC outloading drawing.

TRANSPORTABILITY DOCUMENTATION

Adequate plans have been made to prepare and publish transportability guidance for Patriot. In addition, the Patriot Project Office (PPO) has requested that the Military Traffic Management Command (MTMC) prepare an all-mode transportability guidance manual for the Patriot missile system. These manuals, with

instructions for packaging, safety, and security, should ensure efficient in-theater transportation of Patriot.

Transportability design data sheets have been prepared to provide data for the development of transportation plans and procedures for the system elements considering

transportability as affected by equipment design. A transportability evaluation report

describing the transportation and handling of the Patriot system has also been prepared.

AIR TRANSPORTABILITY

Patriot is transportable aboard heavy transport aircraft to include the C-141 and C-5A. Palletization of component modules is acceptable for transport aboard the C-141. The following table details specific requirements concerning payload removal required for transport aboard C-141 aircraft. Tractors and trailers may be separated for air transport; however, the system mounted on vehicles can be loaded on C-5A aircraft without payload off-loading.

All Patriot components in shipping configuration meet aircraft transport requirements as determined through analysis. The M983 truck-tractor and the M939-series trucks have been

certified by the Air Force as being transportable by the C-141 and C-5A. Engineering development equipment, including the RS and ECS, have been flown in a C-5A between WSMR, New Mexico and Bedford, Massachusetts without incident. Dimensional and weight data on all Patriot components not previously reviewed by the Air Force have been submitted to the Air Force for analysis and air transportability certification. No Patriot items, except the GM, are internally transportable by Army helicopters, although the CH-47 and CH-54 models can transport several components, such as the ECS and ICC shelters, as external loads.

Table E-1. Transport modes requiring dismounting.

	AIR (C-141)	RAIL	WATER	ROAD
ECS	X	X	---	---
RS	X(1)	X(1)	---	---
LS	(1)	(1)	---	---
ICC	X	X	---	---
CRG	X	X	---	---
AMG	X	X	---	---
EPP	(2)	---	---	---
MC	(3)	(3)	---	---
SRPT	(3)	(3)	---	---

Notes:

X Payload must be removed.

1 Outriggers must be removed.

2 Forward generator must be removed and tire pressure reduced to meet overall height restriction of 103 inches.

3 Dolly must be removed.

CARGO DIMENSIONAL CHARACTERISTICS, C-141

Cargo Compartment Dimension

- Length: 1,251 inches.
- Width: 123 inches.
- Height: 109 inches. Cargo must be six inches from the side and top of aircraft. Ramp height is restricted to 80 inches other than palletized.
- Peacetime planning ACL: 50,000 pounds.

Cargo Area

- Main cargo floor: Station 322 to 1412 (1,090 inches).
- Ramp: Station 1412 to 1543 (131 inches).

Loading Maximum Weights

- Stations 322 to 678 and 998 to 1412: 10,000-pound axles.
- Station 678 to 998: 20,000 -pound axles.
- Station 1412 to 1543 (ramp): 7,500-pound axles.
- Maximum individual wheel weight: 5,000 pounds.

CARGO DIMENSIONAL CHARACTERISTICS, C-5

Cargo Compartment Dimension

- Length: 1,736 inches.
- Width: 228 inches.
- Height: 162 inches. Cargo must be six inches from the side and top of aircraft.
- Peacetime planning ACL: 151,400 pounds.

Cargo Area

- Main cargo floor: Station 511 to 1976 (1,465 inches).
- Forward ramp: Station 395 to 511 (116 inches).
- Aft ramp: Station 1976 to 2131 (155 inches).

Loading Maximum Weights

- Stations 395 to 511 and 1976 to 2131 (ramps): 3,600 pounds in any 20-inch area.
- Stations 511 to 724 and 1884 to 1976: 20,000 pounds in any 40-inch area.
- Station 724 to 1884: 36,000 pounds in any 40-inch area.

EQUIPMENT DIMENSIONAL CHARACTERISTICS

RADAR SET, SEMITRAILER-MOUNTED, AN/MPQ-53

Special Requirements for C-5

The RS consists of a multifunction phased-array radar mounted on an M860A1 semitrailer towed by an M983 tractor. The RS/M860A1 semitrailer/M983 tractor combination can be transported by C-5 in the road march configuration. Because of the size and payload capabilities of the C-5, the RS/M860A1/M983 payload can be located almost anywhere in the cargo area. However, the location of the

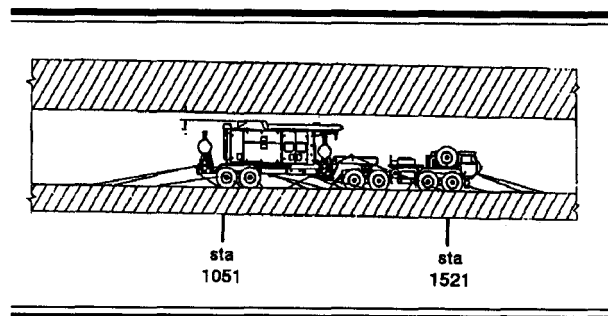

Figure E-1. Radar set, semitrailer-mounted, C-5.

combined CG of the total load must be within the limits of the aircraft for the total weight of the cargo. Tie-down spacing provisions must also be considered in the location of the payload within the C-5. The RS/M860A1/M983 configuration can be rolled through the C-5 cargo compartment without interfering with the walls or ceiling of the cargo area.

Special Requirements for C-141

The RS must be off-loaded from the M860A1 semitrailer for C-141 air transport. The semitrailer cannot be loaded onto the C-141 aircraft without first removing the outriggers. The actuator portion of the outrigger assembly may remain attached to the semitrailer, be raised to a vertical position and secured using metal strapping with a 2-inch x 4-inch x 96-inch spacer, notched at each end, placed between opposite outrigger actuators. Specialized lifting and handling equipment is necessary to dismount and load the RS for transport in a sectionalized configuration. The RS is loaded on a pallet train consisting of three HCU-6/E cargo pallets married together. One 30-ton crane is required to remove the RS from the M860A1 trailer and load it onto pallets. A 40 K-loader is then required to load the palletized RS into the cargo area of the aircraft. There are

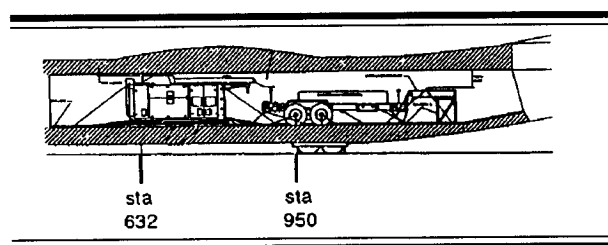

Figure E-2. Radar set, C-141.

no lateral or vertical interference problems between the RS and the C-141 aircraft.

LAUNCHING STATION, GUIDED MISSILE, SEMITRAILER-MOUNTED, M901

Special Requirements for C-5

The LSs are remotely operated, fully self-contained units, carrying integral onboard power and up to four guided missiles. The LS is mounted on an M860A1 semitrailer towed by an M983 tractor. The LS/M860A1 semitrailer/M983 tractor combination can be transported by C-5 with or without the missile-rounds (Only three missile-rounds can be loaded onto the LS for C-5 transport due to overhead clearance or interference with the curvature of the ceiling of the cargo compartment. The fourth missile-round should be loaded on a pallet in the same aircraft). Because of the size and payload capabilities of the C-5, the LS/M860A1/M983 payload can be located almost anywhere in the cargo area. However, the location of the combined CG of the total load must be within the limits of the aircraft for the total weight of the cargo. Tie-down spacing provisions must also be considered

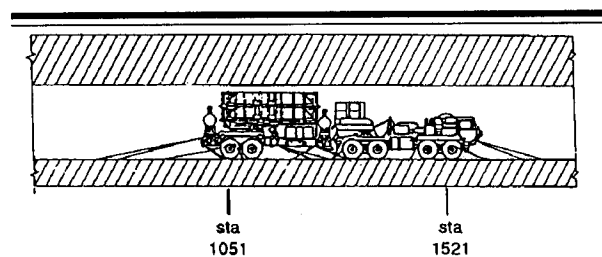

Figure E-3. Launching station, guided missile, semitrailer-mounted, C-5.

in the location of the payload within the C-5. The LS/M860A1/M983 configuration can be rolled through the C-5 cargo compartment without interfering with the walls or ceiling of the cargo area.

Special Requirements for C-141

The semitrailer cannot be loaded onto the C-141 aircraft without first removing the missile-rounds, outriggers, and the launcher's onboard power source, an MEP-113A 15-kilowatt diesel engine-driven generator. The actuator portion of the outrigger assembly may remain attached to the semitrailer, be raised to a vertical position and secured using metal strapping with a 2-inch x 4-inch x 96-inch spacer, notched at each end, placed between opposite outrigger actuators. Specialized lifting and handling equipment is necessary to dismount and palletize the generator for transport. A crane, forklift, or other lifting device is required to remove the generator from the M860A1 semitrailer and load it onto a pallet. A 40 K-loader is then required to load the palletized generator into the cargo area of the aircraft. There are no lateral or vertical interference problems between the LS and the C-141 aircraft.

HEAVY EXPANDED MOBILITY TACTICAL TRUCK, 10-TON, M983

Special Requirements for C-5

The M983 10-ton HEMTT is the prime mover for the M860A1 semitrailer-mounted Patriot radar set and launching station. The M983 truck can be transported by C-5 without disassembly. Because of the size and payload capabilities of the C-5, the M983 can be located almost anywhere in the cargo area. However, the location of the combined CG of the total load must be within the limits of the aircraft for the total weight of the cargo. Tie-down spacing provisions must also be considered in the location of the M983 within the C-5.

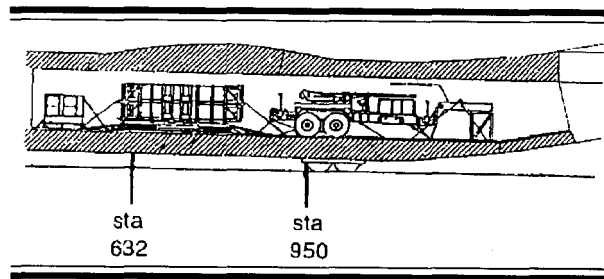

Figure E-4. Launching station, guided missile, C-141.

The M983 can be driven through the C-5 cargo compartment without interfering with the walls or ceiling of the cargo area.

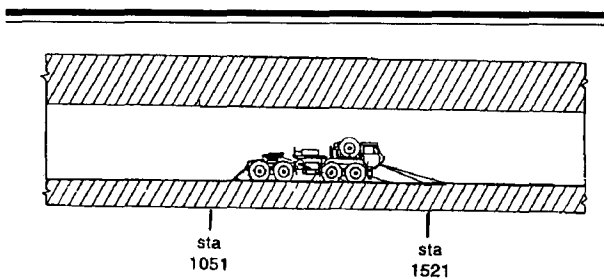

Figure E-5. HEMTT, 10-ton, C-5.

Special Requirements for C-141

The M983 truck can be transported by C-141 without disassembly; however, the spare tire must be removed from the vehicle in order to load into the C-141. It can be driven into the aircraft, eliminating the use of pallets. The location of the combined CG of the total load must be within the limits of the aircraft for the

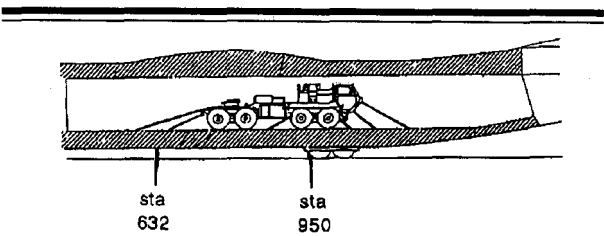

Figure E-6. HEMTT, 10-ton, C-141.

total weight of the cargo. Tie-down spacing provisions must also be considered in the location of the M983 within the C-141. There are no lateral or vertical interference problems between the M983 truck and the C-141 aircraft.

SEMITRAILER, FLATBED, M860A1

Special Requirements for C-5

The M860A1 semitrailer is the trailer used to transport the Patriot radar set and launching station. The M860A1 semitrailer can be transported by C-5 with or without its mission payload. Because of the size and payload capabilities of the C-5, the M860A1 can be located almost anywhere in the cargo area. However, the location of the combined CG of the total load must be within the limits of the aircraft for the total weight of the cargo. Tie-down spacing provisions must also be considered in the location of the payload within the C-5. The M860A1 configuration can be rolled through the C-5 cargo compartment without interfering with the walls or ceiling of the cargo area. Since the M860A1 semitrailer does not have an on-board mobility source, a prime mover, tow motor, or other suitable handling equipment is necessary to load the M860A1 semitrailer into the C-5 aircraft.

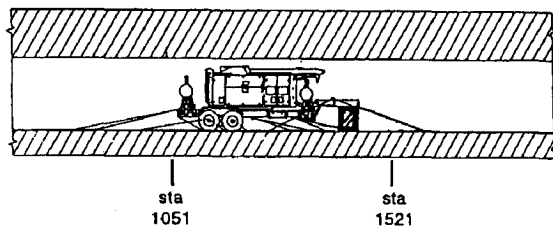

Figure E-7. RS on semitrailer, flatbed, C-5.

Special Requirements for C-141

The M860A1 semitrailer cannot be loaded onto the C-141 aircraft with its mission payload

or the outriggers. The actuator portion of the outrigger assembly may remain attached to the semitrailer, be raised to a vertical position and secured using metal strapping with a 2-inch x 4-inch x 96-inch spacer, notched at each end, placed between opposite outrigger actuators. The location of the combined CG of the total load must be within the limits of the aircraft for the total weight of the cargo. Tie-down spacing provisions must also be considered in the location of the payload within the C-141. Since the M860A1 semitrailer does not have an on-board mobility source, a prime mover, tow motor, or other suitable handling equipment is necessary to load the M860A1 semitrailer into the C-141 aircraft. There are no lateral or vertical interference problems between the M860A1 semitrailer and the C-141 aircraft.

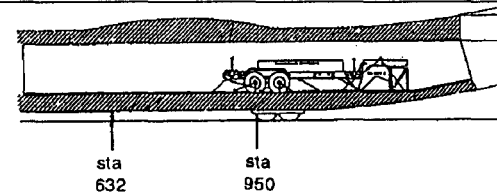

Figure E-8. Semitrailer, flatbed, C-141.

ENGAGEMENT CONTROL STATION, TRUCK-MOUNTED, AN/MSQ-104

Special Requirements for C-5

The ECS shelter is mounted on an M927 truck and is the operational control center of the Patriot FU. The ECS shelter/M927 truck combination can be transported by C-5 in the road march configuration. Because of the size and payload capabilities of the C-5, the ECS/M927 payload can be located almost anywhere in the cargo area. However, the location of the combined CG of the total load must be within the limits of the aircraft for the total weight of the cargo. Tie-down spacing

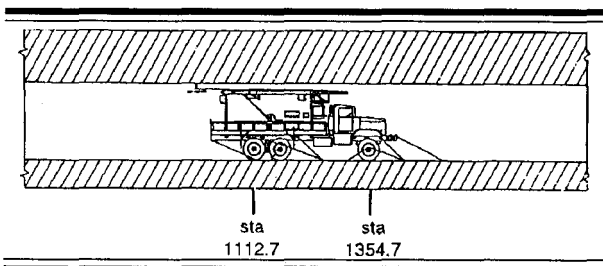

Figure E-9. ECS, truck-mounted, C-5.

provisions must also be considered in the location of the payload within the C-5. The ECS/M927 configuration can be rolled through the C-5 cargo compartment without interfering with the walls or ceiling of the cargo area.

Special Requirements for C-141

The ECS shelter must be off-loaded from the M927 carrier vehicle for C-141 transport. The shelter is loaded on a pallet train consisting of three HCU-6/E cargo pallets married together. The M927 must be height reduced by removing the cabin top and windshield for loading into the C-141. The location of the combined CG of the total load must be within the limits of the aircraft for the total weight of the cargo. Tie-down spacing provisions must also be considered in the location of the payload within the C-141. Specialized lifting and handling equipment is necessary to dismount and load the ECS shelter for transport in a sectionalized configuration. One 30-ton crane is required to remove the shelter from the M927 truck and load it onto pallets. A 40 K-loader is then required to load the palletized shelter into the cargo area of the aircraft. There are no

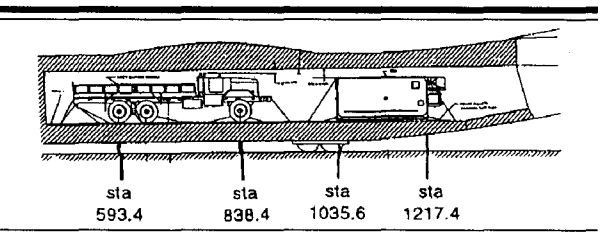

Figure E-10. ECS and carrier vehicle, C-141.

lateral or vertical interference problems between the ECS shelter or M927 truck and the C-141 aircraft.

ENGAGEMENT CONTROL STATION

Special Requirements for C-141

The off-loaded ECS shelter is C-141 transportable. The location of the combined CG of the total load must be within the limits of the aircraft for the total weight of the cargo. Tie-down spacing provisions must also be considered in the location of the payload within the C-141. Since the shelter does not have an on-board mobility source, cargo handling equipment is necessary to load it into the C-141 aircraft. One 30-ton crane is required to load the shelter onto pallets. A 40 K-loader is then required to load the palletized shelter into the cargo area of the aircraft. There are no lateral or vertical interference problems between the ECS shelter and the C-141 aircraft.

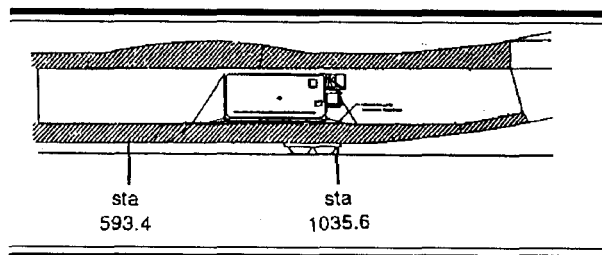

Figure E-11. ECS, C-141.

INFORMATION AND COORDINATION CENTRAL, TRUCK-MOUNTED, AN/MSQ-116

Special Requirements for C-5

The ICC shelter is mounted on an M927 truck and is similar in appearance to the ECS. The ICC contains modems to permit communication with higher echelon units than the ECS. The ICC shelter/M927 truck combination can

be transported by C-5 in the road march configuration. Because of the size and payload capabilities of the C-5, the ICC/M927 payload can be located almost anywhere in the cargo area. However, the location of the combined CG of the total load must be within the limits of the aircraft for the total weight of the cargo. Tie-down spacing provisions must also be considered in the location of the payload within the C-5. The ICC/M927 configuration can be rolled through the C-5 cargo compartment without interfering with the walls or ceiling of the cargo area.

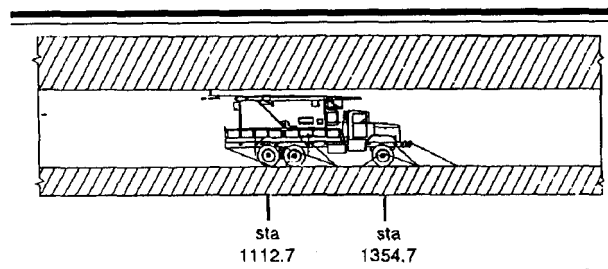

Figure E-12. ICC, truck-mounted, C-5.

Special Requirements for C-141

The ICC shelter must be off-loaded from the M927 carrier vehicle for C-141 transport. The shelter is loaded on a pallet train consisting of three HCU-6/E cargo pallets married together. The M927 must be height reduced by removing the cabin top and windshield for loading into the C-141. The location of the combined CG of the total load must be within the limits of the aircraft for the total weight of the cargo. Tie-down spacing provisions must also be considered in the location of the payload within the C-141. Specialized lifting and handling equipment is necessary to dismount and load the ICC shelter for transport in a sectionalized configuration. One 30-ton crane is required to remove the shelter from the M927 truck and load it onto pallets. A 40 K-loader is then required to load the palletized shelter

into the cargo area of the aircraft. There are no lateral or vertical interference problems between the ICC shelter or M927 truck and the C-141 aircraft.

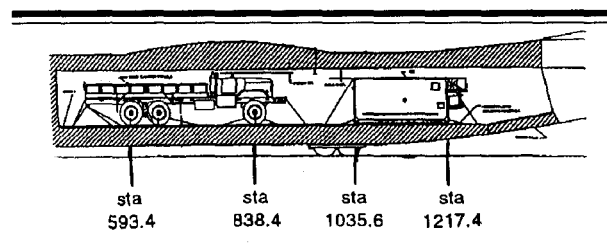

Figure E-13. ICC and carrier vehicle, C-141.

INFORMATION AND COORDINATION CENTRAL

Special Requirements for C-141

The off-loaded ICC shelter is C-141 transportable. The location of the combined CG of the total load must be within the limits of the aircraft for the total weight of the cargo. Tie-down spacing provisions must also be considered in the location of the payload within the C-141. Since the shelter does not have an on-board mobility source, cargo handling equipment is necessary to load it into the C-141 aircraft. One 30-ton crane is required to load the shelter onto pallets. A 40 K-loader is then required to load the palletized shelter into the cargo area of the aircraft. There are no lateral or vertical interference problems between the ICC shelter and the C-141 aircraft.

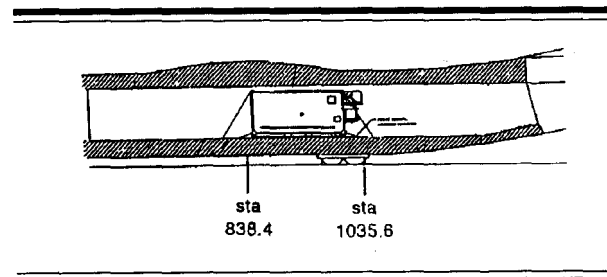

Figure E-14. ICC, C-141.

COMMUNICATIONS RELAY GROUP, TRUCK-MOUNTED, AN/MRC-137

Special Requirements for C-5

The CRG is mounted on an M927 truck and provides a multirouted, secure, two-way data relay capability between the ICC and its assigned FUs and between adjacent units. The CRG shelter/M927 truck combination can be transported by C-5 in the road march configuration. Because of the size and payload capabilities of the C-5, the CRG/M927 payload can be located almost anywhere in the cargo area. However, the location of the combined CG of the total load must be within the limits of the aircraft for the total weight of the cargo. Tie-down spacing provisions must also be considered in the location of the payload within the C-5. The CRG/M927 configuration can be rolled through the C-5 cargo compartment without interfering with the walls or ceiling of the cargo area.

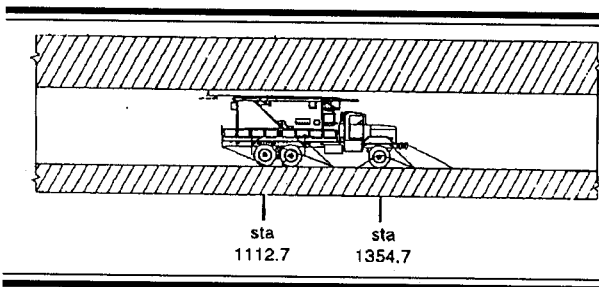

Figure E-15. CRG, truck-mounted, C-5.

Special Requirements for C-141

The CRG shelter must be off-loaded from the M927 carrier vehicle for C-141 transport. The shelter is loaded on a pallet train consisting of three HCU-6/E cargo pallets married together. The M927 must be height reduced by removing the cabin top and windshield for loading into the C-141. The location of the combined CG of the total load must be within

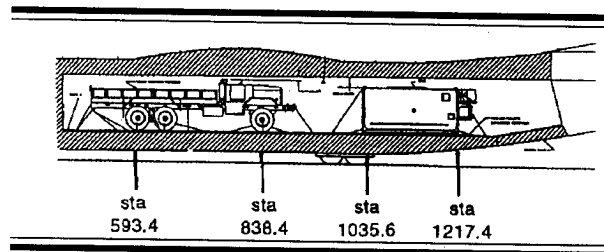

Figure E-16. CRG with carrier vehicle, C-141.

the limits of the aircraft for the total weight of the cargo. Tie-down spacing provisions must also be considered in the location of the payload within the C-141. Specialized lifting and handling equipment is necessary to dismount and load the CRG shelter for transport in a sectionalized configuration. One 30-ton crane is required to remove the shelter from the M927 truck and load it onto pallets. A 40 K-loader is then required to load the palletized shelter into the cargo area of the aircraft. There are no lateral or vertical interference problems between the CRG shelter or M927 truck and the C-141 aircraft.

COMMUNICATIONS RELAY GROUP

Special Requirements for C-141

The off-loaded CRG shelter is C-141 transportable. The location of the combined CG of the total load must be within the limits of the aircraft for the total weight of the cargo. Tie-down spacing provisions must also be considered in the location of the payload within the C-141. Since the shelter does not have an on-board mobility source, cargo handling equipment is necessary to load it into the C-141 aircraft. One 30-ton crane is required to load the shelter onto pallets. A 40 K-loader is then required to load the palletized shelter into the cargo area of the aircraft. There are no lateral or vertical interference problems between the CRG shelter and the C-141 aircraft.

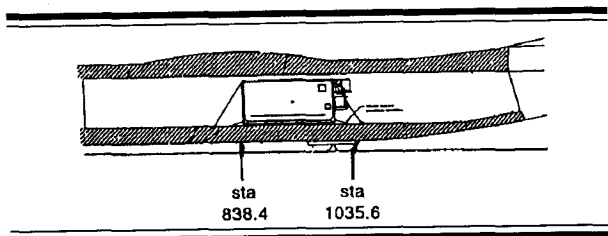

Figure E-17. CRG, C-141.

TRUCK, M927

Special Requirements for C-141

The M927 truck is the prime carrier used for the Patriot ECS, ICC, and CRG shelters. The M927 must be height reduced to 91 inches by removing the cabin top and windshield for loading into the C-141. Because of the size and payload capabilities of the C-141, the M927 can be located almost anywhere in the cargo area. However, the location of the combined CG of the total load must be within the limits of the aircraft for the total weight of the cargo. Tie-down spacing provisions must also be considered in the location of the M927 within the C-141. There are no lateral or vertical interference problems between the M927 truck and the C-141 aircraft.

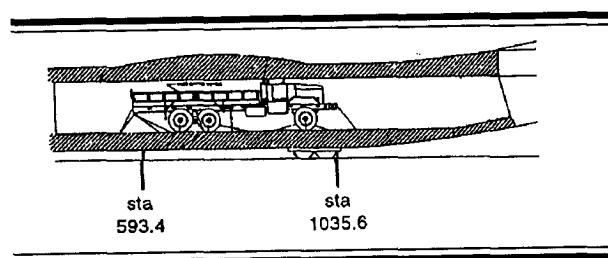

Figure E-18. M927 truck, C-141.

LARGE REPAIR PARTS TRANSPORTER, M977

Special Requirements for C-5

The M977 LRPT cargo truck provides a means to transport and store large, heavy repair

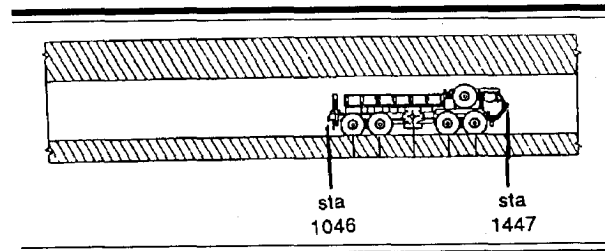

Figure E-19. LRPT, C-5.

parts required for Patriot equipment. The M977 truck can be transported by C-5 without disassembly. Because of the size and payload capabilities of the C-5, the M977 can be located almost anywhere in the cargo area. However, the location of the combined CG of the total load must be within the limits of the aircraft for the total weight of the cargo. Tie-down spacing provisions must also be considered in the location of the M977 within the C-5. The M977 can be driven through the C-5 cargo compartment without interfering with the walls or ceiling of the cargo area.

Special Requirements for C-141

The M977 truck can be transported by C-141 without disassembly; however, the spare tire must be removed from the vehicle in order to load into the C-141. The location of the combined CG of the total load must be within the limits of the aircraft for the total weight of the cargo. Tie-down spacing provisions must also be considered in the location of the M977 within the C-141. There are no lateral or vertical interference problems between the M977 truck and the C-141 aircraft.

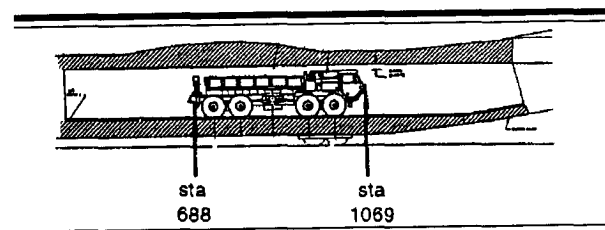

Figure E-20. LRPT, C-141.

GUIDED MISSILE TRANSPORTER, M985E1

Special Requirements for C-5

The M985E1 GMT cargo truck is used for delivery, recovery, and loading of guided missiles. The M985E1 truck can be transported by C-5 with or without a payload of guided missiles. Because of the size and payload capabilities of the C-5, the M985E1 can be located almost anywhere in the cargo area. However, the location of the combined CG of the total load must be within the limits of the aircraft for the total weight of the cargo. Tie-down spacing provisions must also be considered in the location of the M985E1 within the C-5. The M985E1 can be driven through the C-5 cargo compartment without interfering with the walls or ceiling of the cargo area.

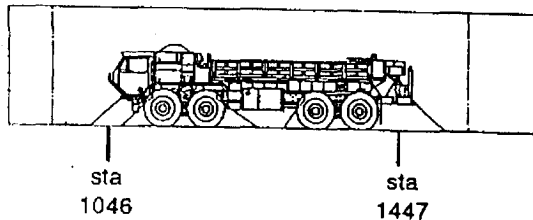

Figure E-21. GMT, C-5.

Special Requirements for C-141

The M985E1 truck can be transported by C-141 without disassembly, however, the missile payload and spare tire must be removed from the vehicle in order to load into the C-141. The location of the combined CG of the total load must be within the limits of the aircraft for the total weight of the cargo. Tie-down spacing provisions must also be considered in the location of the M985E1 within the C-141. There are no lateral or vertical interference problems between the M985E1 truck and the C-141 aircraft.

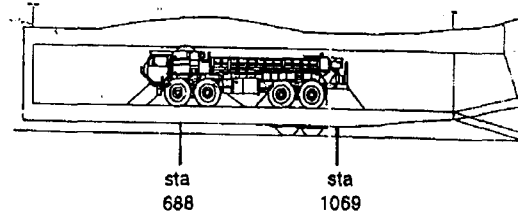

Figure E-22. GMT, C-141.

ANTENNA MAST GROUP, TRUCK-MOUNTED, OE-349/MRC

Special Requirements for C-5

The AMG is mounted on an M942 truck and is a mobile antenna mast system used to carry the amplifiers and antennas associated with the UHF communications equipment in the ECS, ICC, and CRG. The AMG/M942 truck combination can be transported by C-5 in the road march configuration. Because of the size and payload capabilities of the C-5, the AMG/M942 payload can be located almost anywhere in the cargo area. However, the location of the combined CG of the total load must be within the limits of the aircraft for the total weight of the cargo. Tie-down spacing provisions must also be considered in the location of the payload within the C-5. The AMG/M942 configuration can be rolled through the C-5 cargo compartment without interfering with the walls or ceiling of the cargo area.

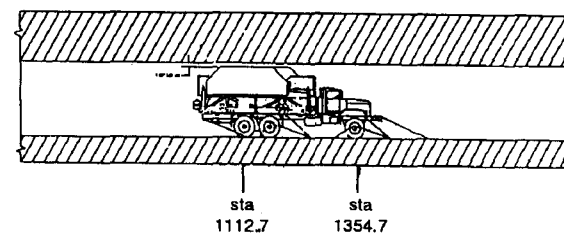

Figure E-23. AMG, truck-mounted, C-5.

Special Requirements for C-141

The AMG must be off-loaded from the M942 carrier vehicle for C-141 transport. The AMG is loaded on a pallet train consisting of three HCU-6/E cargo pallets married together. The M942 must be height reduced by removing the cabin top and windshield for loading into the C-141. The location of the combined CG of the total load must be within the limits of the aircraft for the total weight of the cargo. Tie-down spacing provisions must also be considered in the location of the payload within the C-141. Specialized lifting and handling equipment is necessary to dismount and load the AMG for transport in a sectionalized configuration. One 30-ton crane is required to remove the AMG from the M942 truck and load it onto pallets. A 40 K-loader is then required to load the palletized AMG into the cargo area of the aircraft. There are no lateral or vertical interference problems between the AMG or M942 truck and the C-141 aircraft.

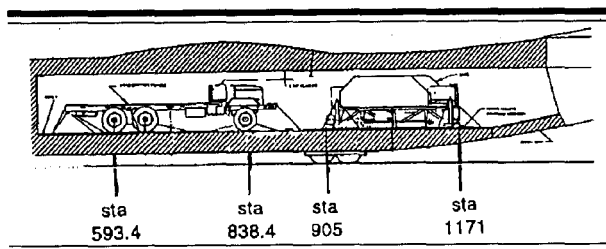

Figure E-24. AMG with carrier vehicle, C-141.

ANTENNA MAST GROUP

Special Requirements for C-141

The off-loaded AMG is C-141 transportable and due to the size and payload capabilities of the C-141, can be located almost anywhere in the cargo area. However, the location of the combined CG of the total load must be

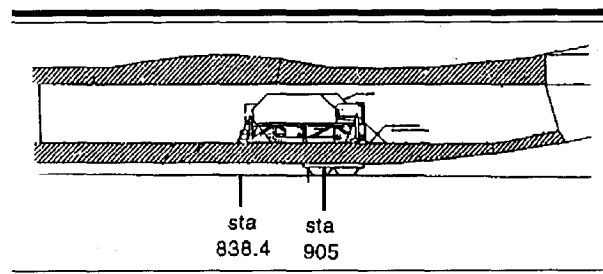

Figure E-25. AMG, C-141.

within the limits of the aircraft for the total weight of the cargo. Tie-down spacing provisions must also be considered in the location of the payload within the C-141. Since the AMG does not have an on-board mobility source, cargo handling equipment is necessary to load it into the C-141 aircraft. One 30-ton crane is required to load the shelter onto pallets. A 40 K-loader is then required to load the palletized shelter into the cargo area of the aircraft. There are no lateral or vertical interference problems between the AMG and the C-141 aircraft.

ELECTRIC POWER PLANT III, TRUCK-MOUNTED, M977EPP

Special Requirements for C-5

The EPP III consists of two interconnected 150-kilowatt, 400-hertz, diesel engines mounted on an M983 HEMTT. It is the prime power source for the ECS and RS. The EPP III/M983 HEMTT combination can be transported by C-5 in the road march configuration. Because of the size and payload capabilities of the C-5, the EPP III/M983 payload can be located almost anywhere in the cargo area. However, the location of the combined CG of the total load must be within the limits of the aircraft for the total weight of the cargo. Tie-down spacing provisions must also be considered in the location of the payload within the C-5. The EPP III/M983 configuration can be rolled through the C-5 cargo compartment without interfering with the walls or ceiling of the cargo area.

Special Requirements for C-141

The diesel engines must be off-loaded from the M983 carrier vehicle for C-141 transport. The M983 must be height reduced by removing the cabin top and windshield for loading into the C-141. The location of the combined CG of the total load must be within the limits of the aircraft for the total weight of the cargo. Tie-down spacing provisions must also be considered in the location of the payload within the C-141. Specialized lifting and handling equipment is necessary to dismount and load the EPP III for transport in a sectionalized configuration. One 30-ton crane is required to remove the diesel engines from the M983 HEMTT and load them onto pallets. A 40 K-loader is then required to load the palletized diesel engines into the cargo area of the aircraft. There are no lateral or vertical interference problems between the palletized diesel engines or M983 HEMTT truck and the C-141 aircraft.

TRUCK, M942

Special Requirements for C-141

The M942 truck is the prime carrier used for the Patriot AMG. The M942 must be height reduced to 93.7 inches by removing the cabin top and windshield for loading into the C-141. Because of the size and payload capabilities of the C-141, the M942 can be located almost anywhere in the cargo area. However, the location of the combined CG of

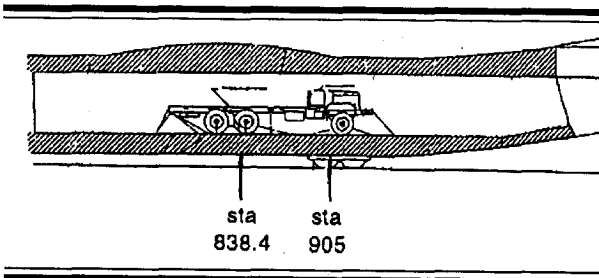

Figure E-26. M942 truck, C-141.

the total load must be within the limits of the aircraft for the total weight of the cargo. Tie-down spacing provisions must also be considered in the location of the M942 within the C-141. There are no lateral or vertical interference problems between the M942 truck and the C-141 aircraft.

ELECTRIC POWER UNIT II, TRAILER-MOUNTED, PU-789

Special Requirements for C-5 and C-141

The EPU II consists of one 30-kilowatt, 400-hertz, diesel engine generator set mounted on a trailer and towed by the ICC or CRG. It is the prime power source for the ICC and CRG. The EPU II is C-5 and C-141 transportable and due to the size and payload capabilities of the aircraft, it can be located almost anywhere in the cargo area. However, the location of the combined CG of the total load must be within the limits of the aircraft for the total weight of the cargo. Tie-down spacing

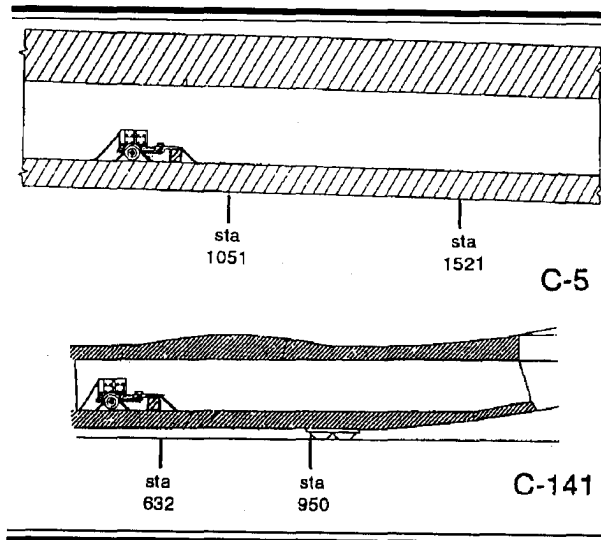

Figure E-27. EPU II and trailer, C-5 and C-141.

APPENDIX F

SAFETY

This appendix provides examples and guidelines concerning safety issues prior to or during combat operations. It also provides some basic rules of safety. Commanders or their representatives must ensure that safety is an ongoing process during wartime, as well as during peacetime training. Each unit must refer to basic regulations and directives for additional information.

ADMINISTRATIVE

Commanders and leaders must be involved in the function of safety in their unit. The following are some administrative safety considerations.

SOPs

The commander must ensure that the safety annex of the unit tactical SOP is current and covers all field training operations.

The commander and or safety officer must be familiar with the safety portions of the SOPs.

RESPONSIBILITIES

The commander ensures that adequate provisions for safe practices, procedures, and physical standards are incorporated into unit functions, activities, exercises, and combat operations. The unit safety officer must keep the commander informed of the unit safety status by reporting all accidents, injuries, and incidents, and recommending corrective actions.

RISK MANAGEMENT PROCESS

Every training exercise or combat operation carries with it inherent risk. Identifying, evaluating, and reducing risk are leader tasks. The following are methods for evaluating risk:

- Risk identification. What is risky versus what is not.
- Risk evaluation and quantification.

How great the risk is.

- Risk reduction. How the risk can be reduced.
- Risk decision making. Determine the priority of the risk.
- Risk decision follow-up. Determine what the risk is and how essential it is.

VEHICLE MOVEMENT AND CONVOYS

Vehicle movements and convoys require leaders to think about safety. The following list is not comprehensive, but is meant to be a start for building a complete safety list for movements:

- Basic issue items must be on every vehicle in convoy.
- Operators and assistant operators must

perform before-, during-, and after-operation PMCS with each movement.

- Radio antennas must be properly tied down.
- Commanders must ensure that operators have been trained to operate vehicles in adverse weather and difficult terrain.
- Operators must be provided with adequate

rest (8 hours rest per 10 hours of driving).

- All vehicle occupants must use available seat restraints.
- Ground guides must be used when appropriate.

- Sleeping in, under, and or near running vehicles is prohibited, as death may result due to carbon monoxide poisoning or accidental movement of the vehicle.
- Fire drills must be practiced on all vehicles.

SAFETY FROM RF RADIATION HAZARDS AND LAUNCHER BACKBLAST

Patriot equipment represents a significant threat to safety if procedures are not properly adhered to. The following list, also not comprehensive, is a look at some things leaders must consider when operating Patriot equipment:

- Personnel will remain more than 120 meters in front of the radar at all times (see Figure F-1).
- Fire control personnel will conduct a visual inspection of the radar to ensure all crew members have vacated the area before placing radar in the remote mode.

- RF radiation warning signs will be posted at the right and left limits of the radar hazard area to warn personnel of the required control measures.

- In all cases of RF radiation exposure or suspected exposure, the affected personnel should be evacuated without delay to the nearest medical facility for an examination by a physician.

- Personnel will never be within 90 meters of a launcher without the TCO knowing because of the extremely hazardous backblast of a Patriot missile.

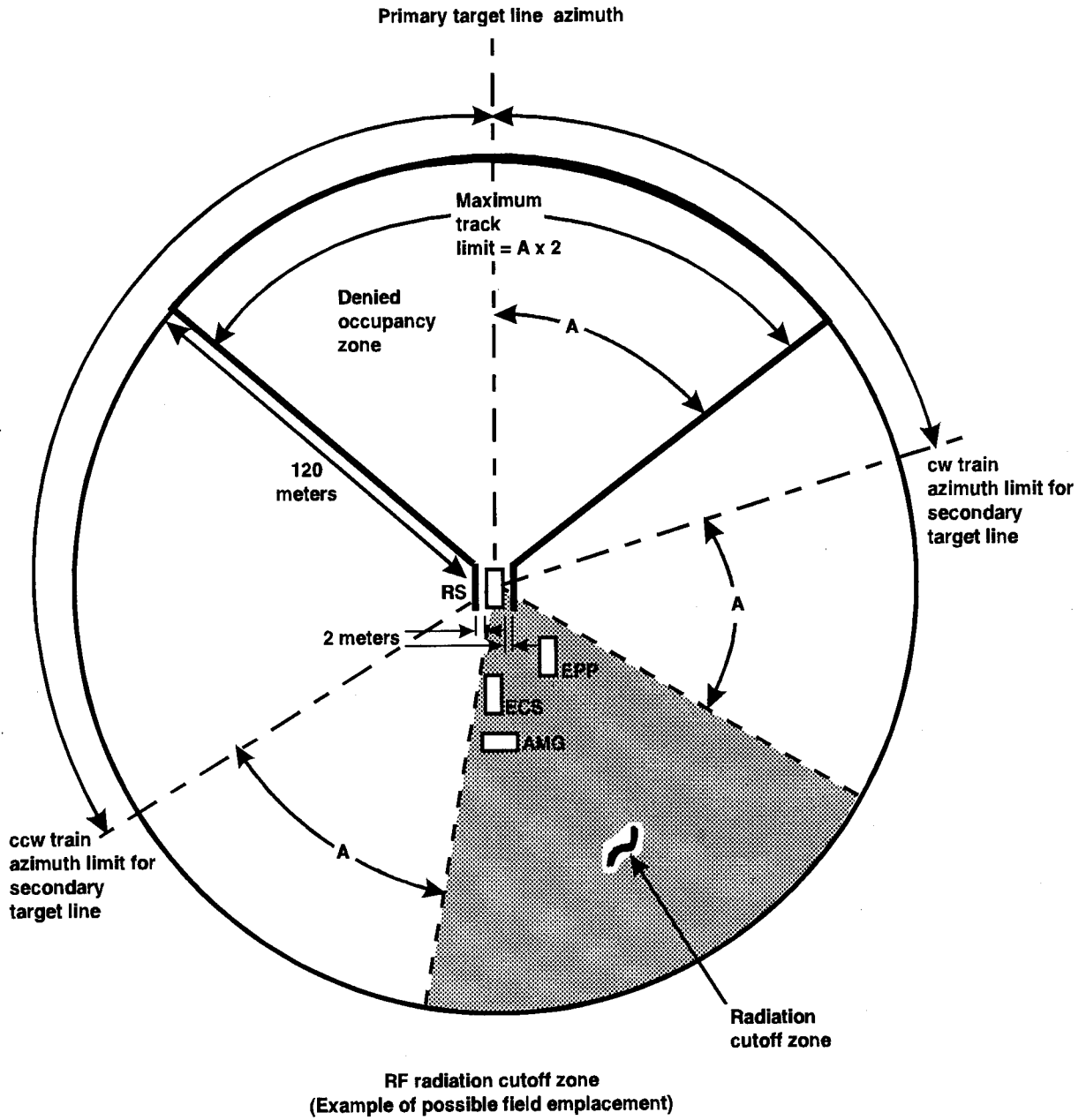

Figure F-1. RF radiation hazard.

APPENDIX G

COMMUNICATIONS

This appendix gives an overview of Patriot communications and equipment to aid in communications planning. The Patriot system relies heavily on data and voice communications. For more complete information, see FM 44-85-1 (TBP).

BATTALION COMMUNICATIONS EQUIPMENT

Patriot uses many types of communications equipment, each with its specific use. The following paragraphs describe communications equipment found at battalion level.

VHF-FM

At the battalion and battery levels, FM radios are in command, logistics, administrative, intelligence, and operations vehicles. Primary FM radios are the SINCGARS with secure COMSEC devices.

IHFR-AM

This is used primarily as backup communications for C² when at a static position. The AN/GRC-106 radio with the dipole antenna is used at battery, battalion, and brigade CPs.

MOBILE SUBSCRIBER EQUIPMENT

The mobile subscriber equipment (MSE) consists of an interface box at the ICC and is hardwired to a small extension node (SEN) van which will transmit the signal to other SENs. The purpose is to allow the battalion to communicate with higher echelons, other ADA units, and anyone in the net.

UHF

This is the main method that Patriot FUs use to communicate using voice and data

channels. The AN/GRC-103, 12-channel, Band III radio sets are in every ICC, ECS, and CRG. Two corner reflector antennas are used for short-range communications, and the AMG is used for long-range communications. Encryption is provided by the KG-194A. The UHF system transmits data through the following methods:

- PADIL—internal for Patriot units.
- ATDL-1—external to brigade and HEUs.
- TADIL-A—external to land-based, airborne, and shipboard tactical data systems.
- TADIL-B—used to communicate with satellites.
- TADIL-J—time-shared net used by airborne, shipboard, and land-based tactical combat operations.

Wire

WD-1 and 26-pair cables are used to connect elements within the battalion and battery for C², administrative, logistics, and CSS. To enhance the capabilities, the wire lines are connected with the UHF to communicate with higher and supporting units.

BATTALION COMMUNICATIONS REQUIREMENTS

The communications system for Patriot battalions must provide reliable, real-time or near real-time information to dispersed Patriot batteries, higher headquarters, adjacent battalions, and supported units. The communications system must be redundant to provide continuous communications even when the primary system fails. To effectively defeat the air threat, the Patriot battalion must maintain communications to support—

- Control of the air battle.
- Command, administrative, and logistical lines with higher headquarters, subordinate units, and lateral units.
- Liaison with supported units or the units in whose area the Patriot battalion is operating.

Each Patriot battalion commander is responsible for establishing an effective communications system. He exercises C² of organic signal assets through his signal officer. The doctrinal responsibilities for establishing communications are found in FMs 24-1 and 101-5. Communications are established from higher to lower, left to right, and supporting to supported, (see FM 24-1). The battalion uses multichannel radio and wire nets to maintain external and internal communications. A communications platoon organic to the Patriot battalion provides external and internal communications for the battalion TOC (extended multichannel radio systems) and limited support to the FUs.

EXTERNAL COMMUNICATIONS

External communications are established with the ADA brigade and adjacent Patriot battalions. The battalion is also capable of communicating with a CRC, brigade, SHORAD, or a Hawk battalion.

ADA Brigade

Communications with the ADA brigade supports air battle C². It also facilitates

administrative, logistical, operational, and intelligence functions. The brigade signal operations company establishes the voice and data links via multichannel radio and MSE between brigade and battalion.

The EAC ADA brigade uses organic MSE resources to install, operate, and maintain a multichannel system between the brigade and subordinate HIMAD, Patriot, and SHORAD battalions. The corps ADA brigade is supported by the corps signal brigade, normally with an MSE SEN at brigade headquarters and required resources at the Patriot battalion location. The Army tactical data link (ATDL), intelligence and radar reporting (IRR), and air defense control (ADC) are circuits routed over the multichannel system.

Generally, three channels are used for control of the air battle. One channel is used for the automatic data link which uses ATDL- 1. Another channel is used by the brigade and battalion tactical directors for the identification function. This is called the IRR line and is usually established on party line two. The third channel is used by the brigade and battalion tactical director assistants (TDAs) for the engagement function. This is called the ADC line and is usually established on party line one. All voice circuits are terminated at the ICC patch panel. The automatic data link is also terminated there, either at the RLRIU or at a modem.

IHFR-AM is used as a voice system for ADC and IRR (see Figure G-1). Battalions establish the AM net with brigade to pass messages and facilitate command, control, and coordination with higher echelons. Because of effective internal communications using UHF links, only a backup AM between battalion and brigade is required.

Adjacent Patriot Battalions

A Patriot battalion establishes a UHF multichannel communications system with an

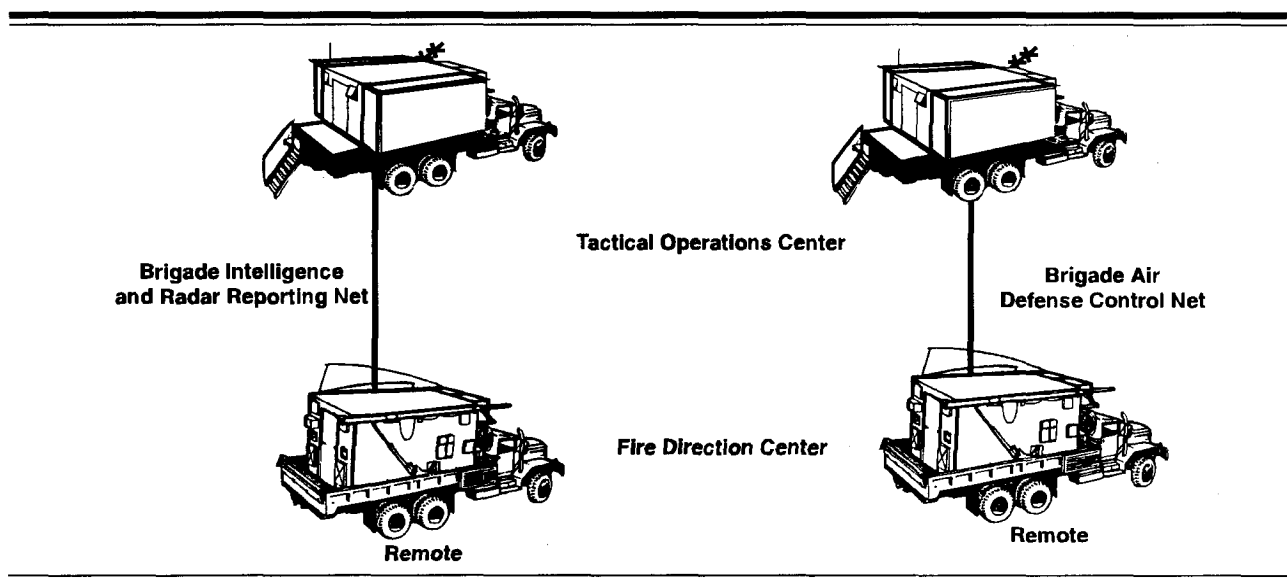

Figure G-1. Backup AM air intelligence and radar reporting.

adjacent Patriot battalion. Generally, one terminal of a CRG is used by each battalion for this external communications link. The link can also be established by the EAC ADA brigade. Because the Patriot UHF equipment provides a more effective link, use of CRGs is recommended for interbattalion communications. The battalions exchange selected information using the Patriot air defense information language (PADIL) at a data exchange rate of 1,200 bits per second. The information is exchanged to improve fire and track coordination.

Supported Unit

Patriot battalions should establish communications with the supported unit or the unit in whose area the battalion is operating. The battalion normally coordinates with the ADCOORD officer on ADA functions. The Patriot battalion will provide early warning to the supported unit using the Patriot command net.

Supporting Unit

Supporting units establish communications with the supported unit. Normally, the direct

support (DS) Patriot maintenance company collocates with or sends a liaison element to the Patriot battalion headquarters. If this is not feasible, the DS Patriot maintenance company enters the Patriot battalion VHF-FM administrative and logistics net. All other units which provide support to the Patriot battalion on an area basis normally do not establish communications with the Patriot battalion. The ADA brigade establishes communications with the COSCOM and TAACOM to provide support for Patriot units.

Combat Radio Net Operations

Command communications use the UHF system as the primary means of communications. SINCGARS is allocated to the Patriot battalion staff to operate in the AD brigade FM command and FM admin/log nets. Distance may be a constraint, in which case UHF multichannel and or MSE via MSRT/VRC-97 is used.

INTERNAL COMMUNICATIONS

Internal communications are established with each Patriot FU to support the battalion

command function. Internal communications also facilitate control of the air battle, administrative, intelligence, operations, and logistics functions, using UHF multichannel and VHF-FM nets.

Multichannel Radio Systems

Patriot battalions use organic resources to establish a multichannel radio system to each subordinate battery. When collocated, an FU can connect via specialty cable directly to battalion. The C² structure is heavily dependent upon communications for efficient operations. To pass real-time air battle and air traffic information, automatic data links must be established. An example of a multirouting scheme is shown in Figure G-2.

To effectively fight the air battle, each FU needs three UHF circuits. One channel on each radio is used for the multirouting of data on the automatic data link circuit. Normally, for standardization, channel four is used. An engagement voice circuit, called ADC, is established using channel one and party line one. An intelligence and radar reporting (IRR) circuit is established using channel two and party line two. An additional circuit is established using channel three and party line three. This is a maintenance circuit and is not used for control of the air battle. Patriot battery TCAs and battalion TDAs use the ADC net. Patriot battery TCOs and battalion TDs use the IRR net.

Battalion Command FM Net

The purpose of this net is to provide communications for the command function within the battalion headquarters. Each station operating in the net is shown in Figure G-3. This is used as the primary C² net during movements and as a secondary net when in a static location.

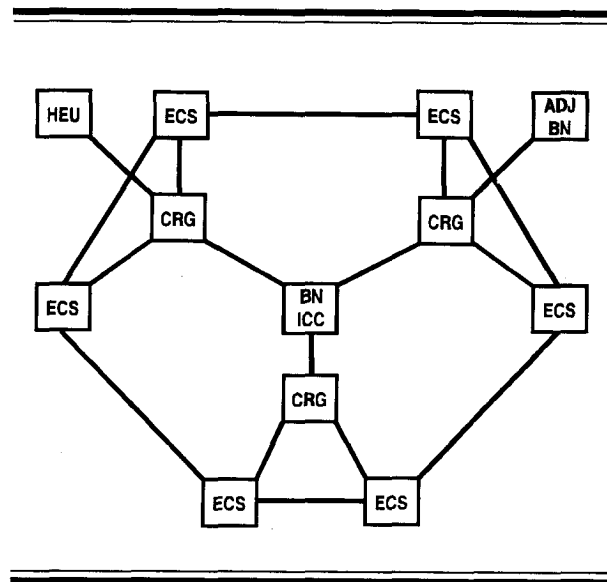

Figure G-2. Battalion UHF links.

Administration, Intelligence, Operations, and Logistics

Normally, the UHF system which provides communications for control of the air battle also supports other functions. Since the UHF system is operational most of the time, it is also the primary means for the staff to provide C² of the FU. The total number of circuits is limited by the 12 external wire connections at the ICC. These 12 circuits must provide connections to brigade and each battery. Generally, each battery has a minimum of one circuit and will frequently have more than one circuit. These UHF circuits are connected to switchboards at the battalion and battery.

Patriot battery and battalion communications operators use the maintenance net. This circuit is an unsecure channel used to coordinate communications circuits. This circuit is similar to other circuits between the battalion and the ADA brigade.

The ICC is linked to the BTOC and the system maintenance center by wire (see

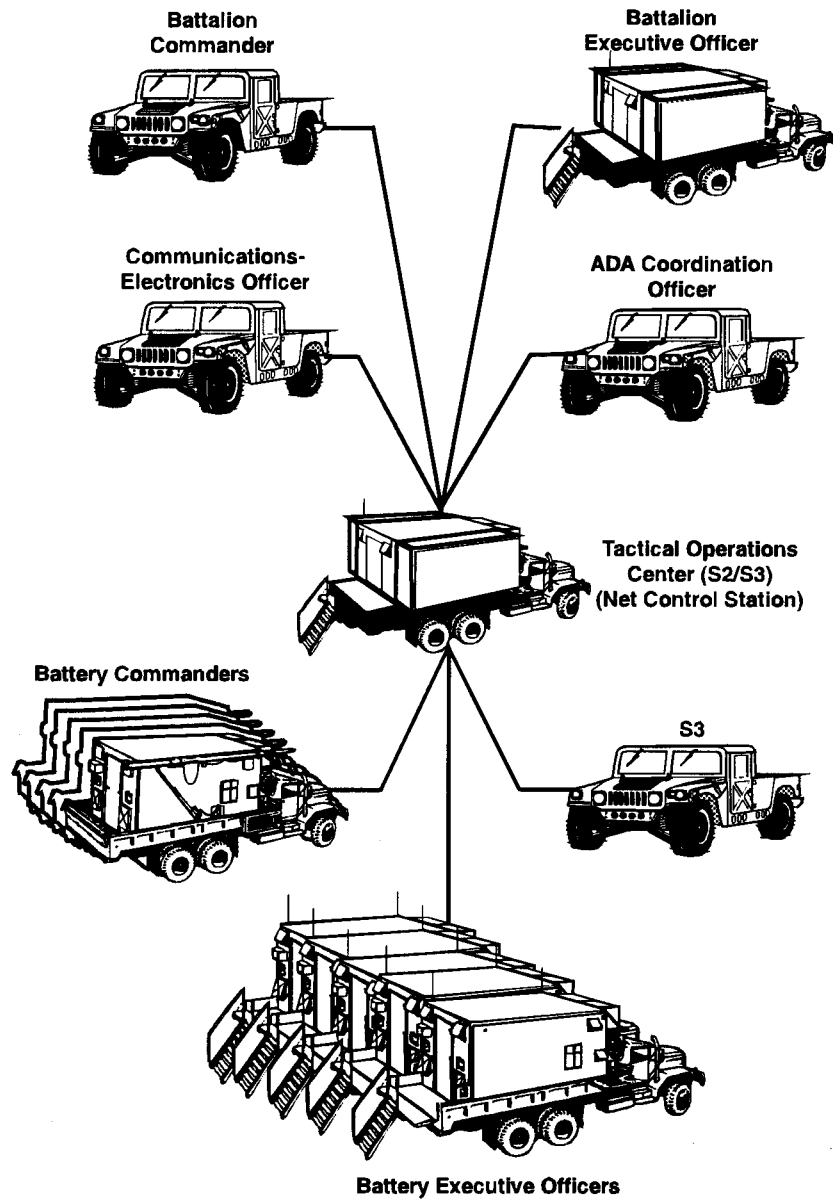

Figure G-3. Battalion command FM net layout.

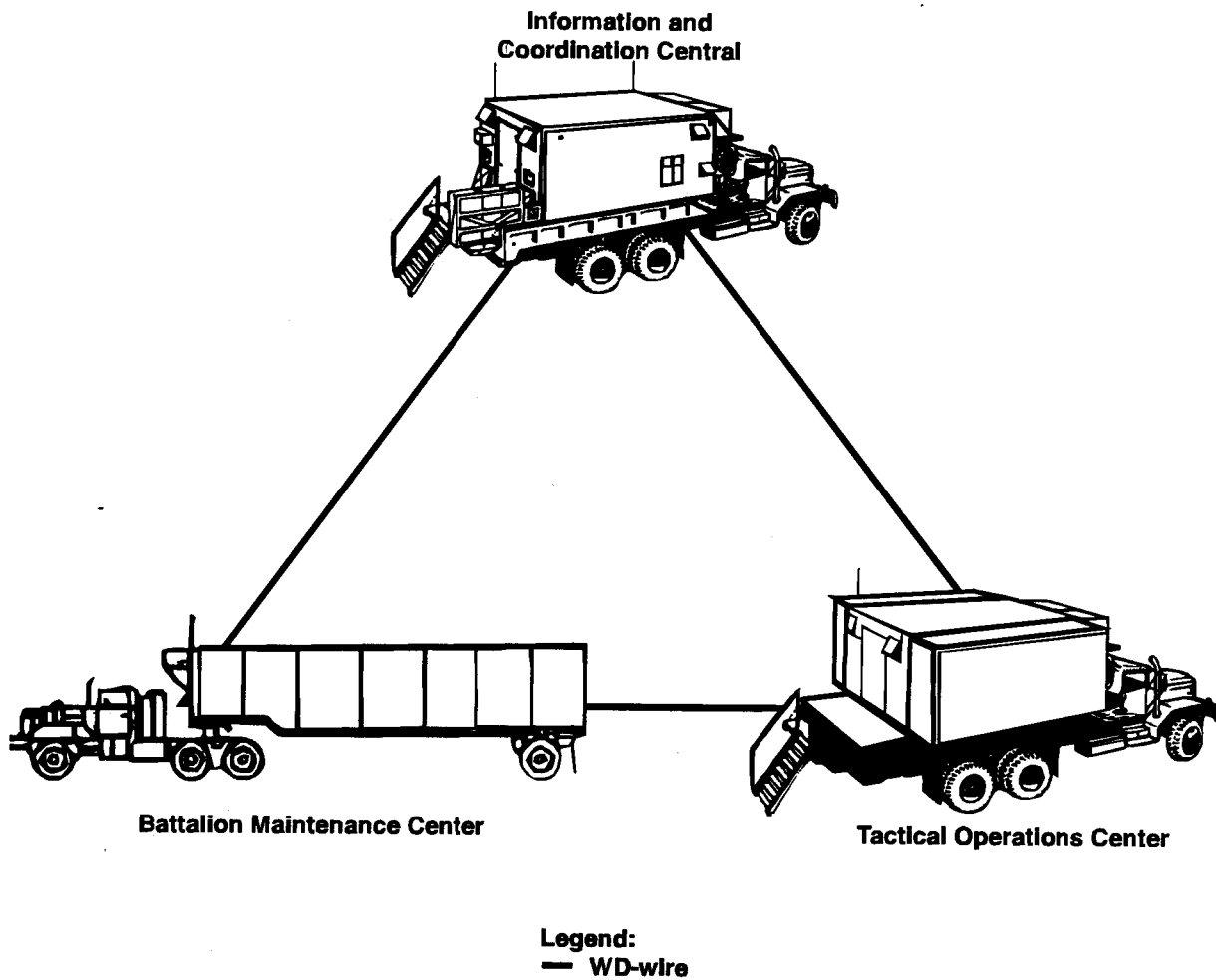

Figure G-4. Battalion intercommunications net.

Figure G-4). This net allows for rapid communications between key elements of the TOC and the ICC. It can be used to cross-tell time-sensitive air battle data such as a change in the airspace control order (ACO). Maintenance support can also be requested without leaving the ICC.

The battalion wire net is shown in Figure G-5. This net is the primary means

of communications between battery elements. The switchboard also provides access to a minimum of one circuit to each FU.

A UHF link provides administrative and logistics C² (see Figure G-6). The net control station is located at the S1 and S4 van. Every station in the net is secure. The net is routed through the ICC with UHF links to higher and supported units.

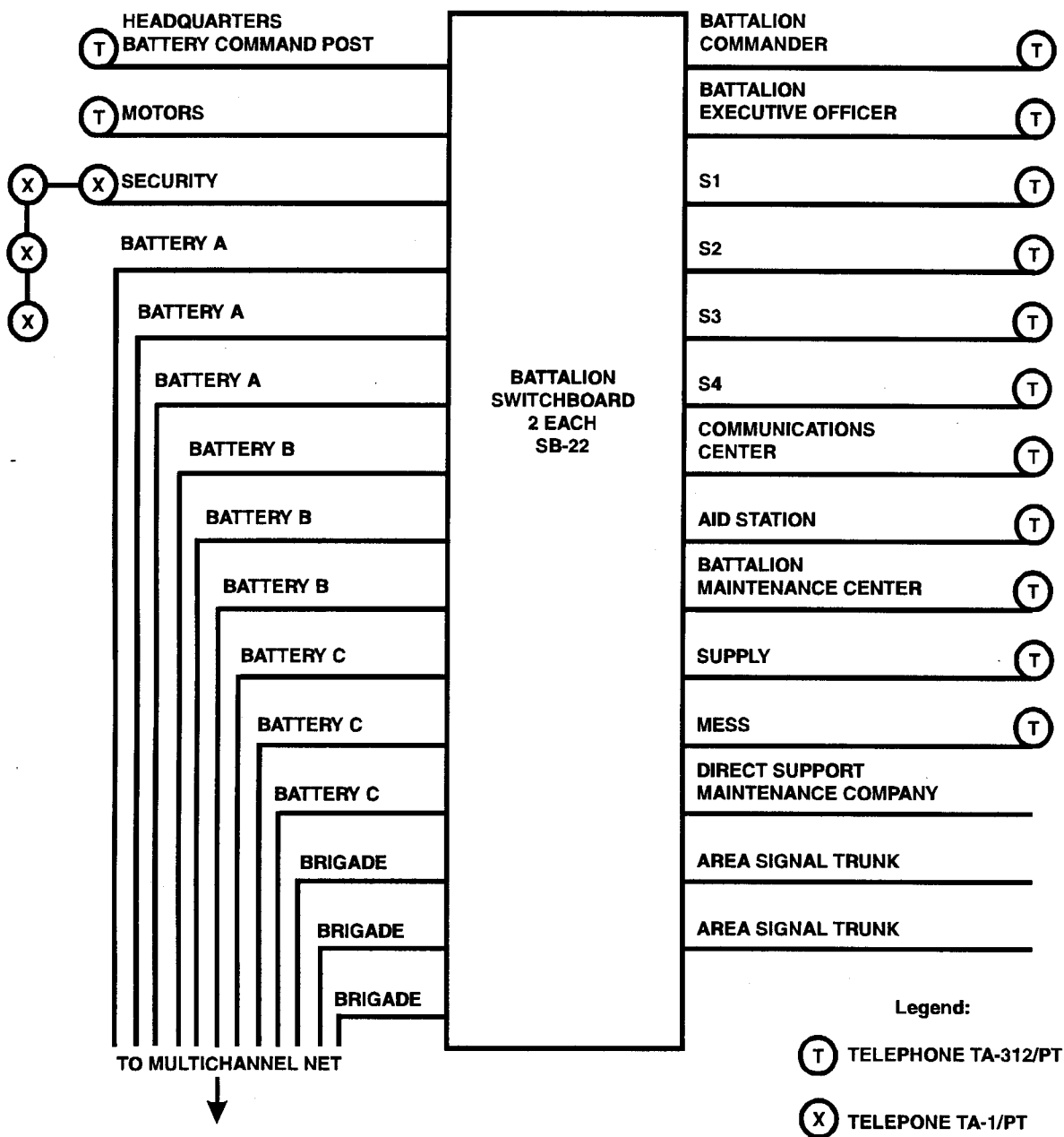

Figure G-5. Battalion wire net.

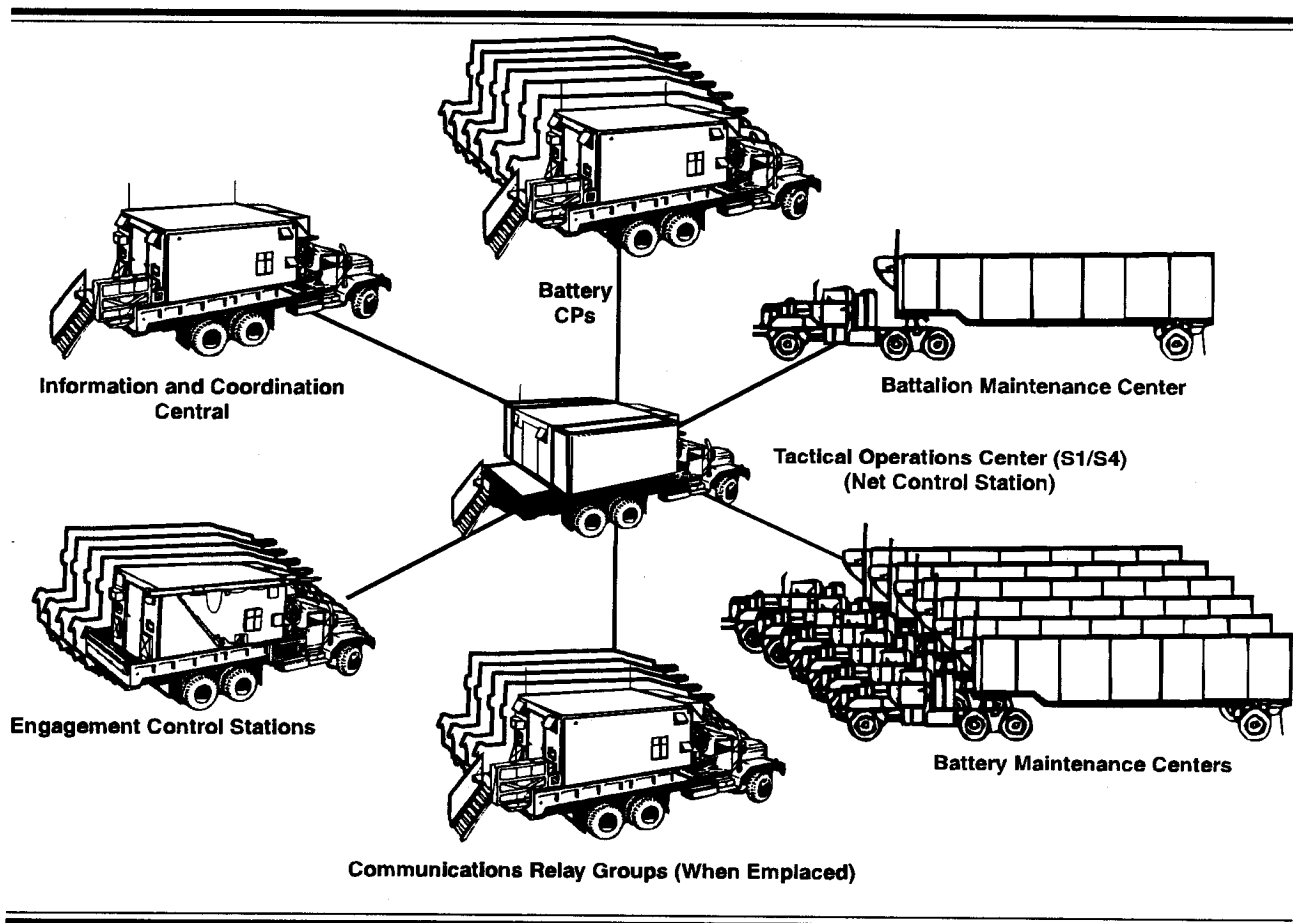

Figure G-6. Battalion administrative/logistics net.

BATTERY COMMUNICATIONS REQUIREMENTS

The communications system for a Patriot battery is composed of three elements. These elements are the C² net, data net, and the wire net.

emplaced, the VHF-FM net is used as a secondary means of communications.

FIRE UNIT COMMAND FM NET

The purpose of this net is to provide communications for the battery command function (see Figure G-7). The net control station is the battery CP. This net is primarily used during unit moves. When the battery is

FIRE UNIT OPERATIONS NET

The FU operations net is used for C² of the fire unit when emplaced (see Figure G-8). The net control station for the battery operations net is the CP. All elements in the net are connected by wire lines. A switchboard at the CP provides a means of control for the battery commander.

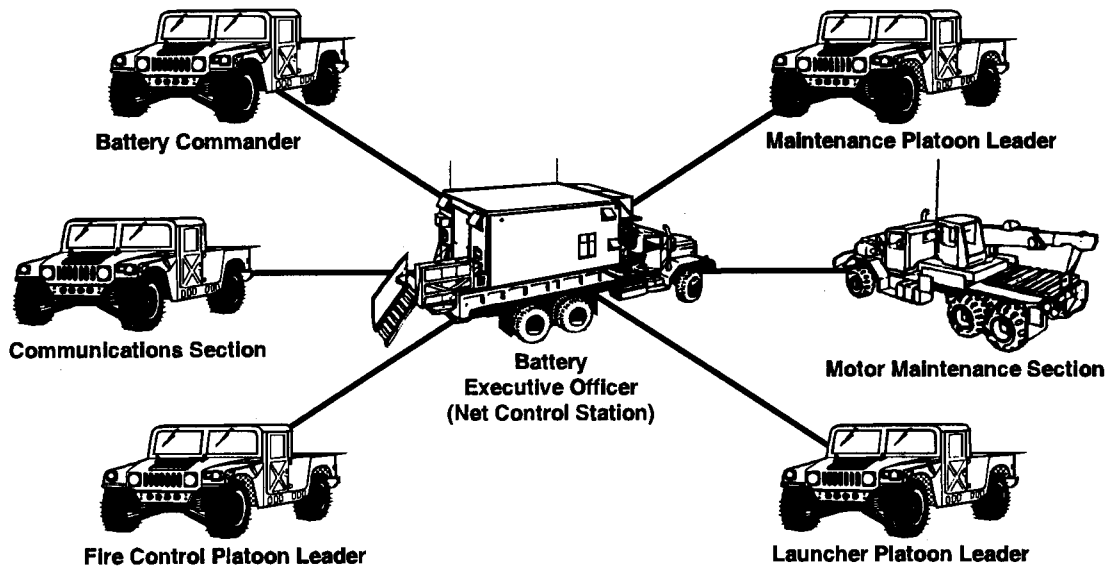

Figure G-7. Fire unit command FM net layout.

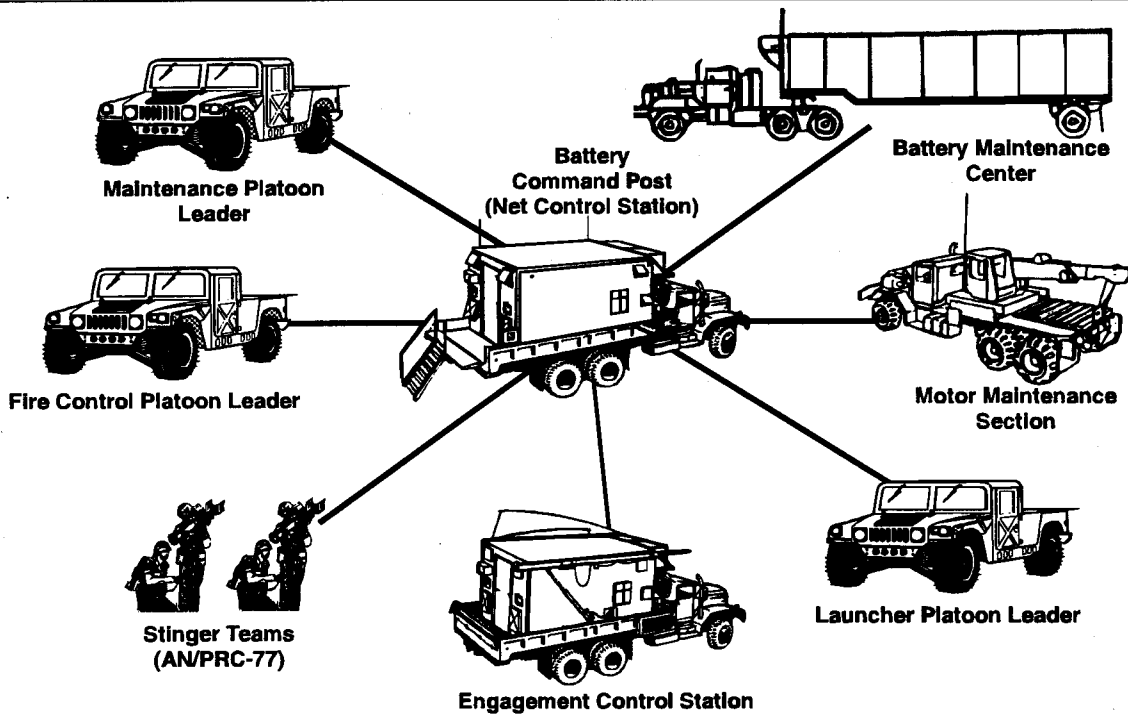

Figure G-8. Fire unit operations net layout.

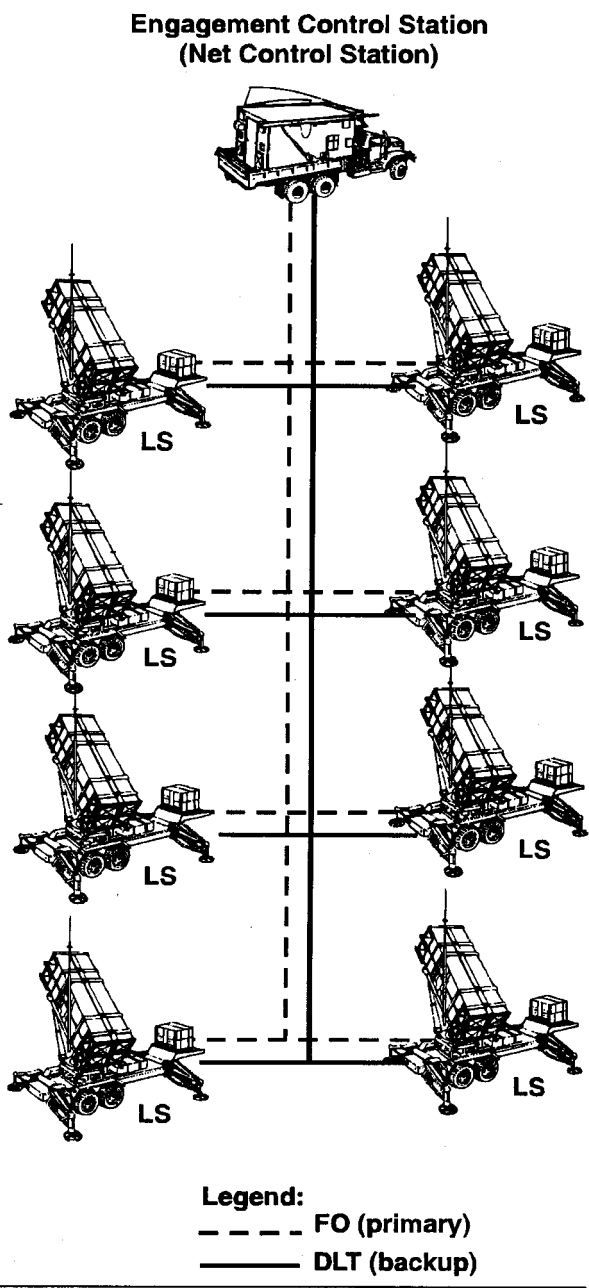

Figure G-9. Fire unit data net.

PATRIOT BATTERY DATA NET

Fiber-optic cables link the ECS to the launching stations. This is to launch missiles and to establish availability and status of missiles. Data radio transmissions are used as backup. The net is controlled at the ECS by special purpose radio equipment which provides reliable transmission of low-data rate messages over a short path (see Figure G-9). All command messages originate at the ECS, requiring a slaved response from the LS in the form of a status message. The LS cannot originate data communications. This is the first net established during battery emplacement.

BATTERY COMMUNICATIONS LAYOUT

The battery wire communications are shown in Figure G-10. Wire is the primary means of communications between elements of the battery. FM radios are used only during movement and until the wire net can be established. A minimum of one circuit to the battalion is available at the switchboard. Normally, the wire lines to the LS connect to ground defense positions.

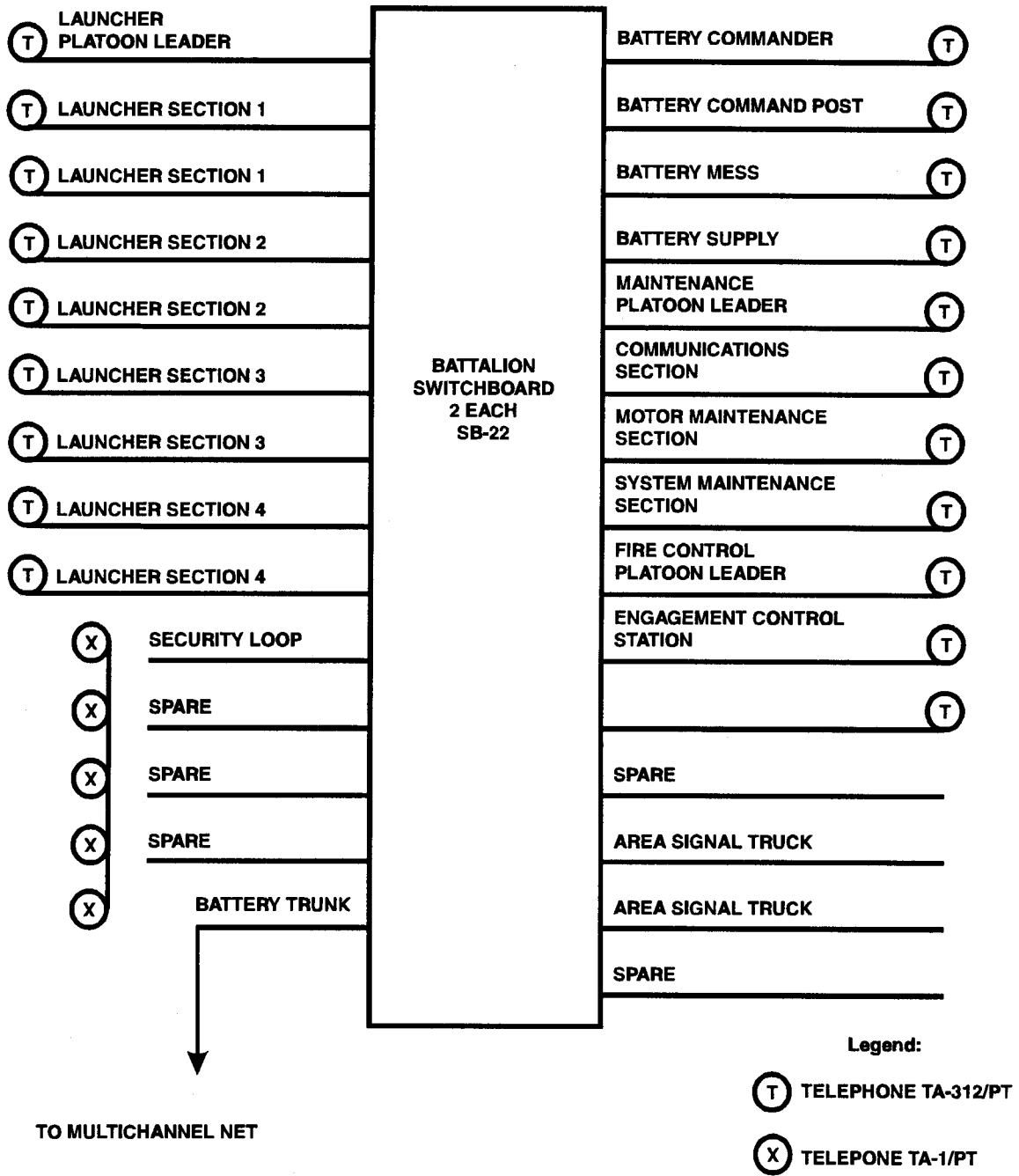

Figure G-10. Battery switchboard connections.

PATRIOT COMMUNICATIONS PLANNING

Patriot communications consist of radio relay terminals (RRTs), RLRIUs, communications patching panel, corner reflectors, AMG, and amplifiers. These items are used to carry out the battalion's communications plan. See appropriate technical manual for a functional description of these items.

PLANNING RESPONSIBILITIES

The signal officer, in conjunction with the S3, coordinates with brigade staff and adjacent battalion signal officers in developing the communications plan prior to each move. A well-developed communications plan minimizes confusion and indecision during moves. The signal officer prepares the communications plan using the CE annex to the TSOP and the SOI. Frequency management personnel can assist him in developing several areas of the plan.

PRIMARY CONSIDERATIONS

When developing the communications plan, the signal officer considers a number of factors. This list is not exhaustive and will vary depending on the situation. The signal officer considers the following actions:

- Identify all network units (interbattalion—total number of Patriot and Hawk FUs, CRGs, and the ICC), interbattalion (adjacent ICCs and GEHOCs), and extrabattalion (brigade TOC elements), and their UTM coordinates. The system can use up to six CRGs.
- Evaluate site terrain for line-of-sight emplacement of AMGs or corner reflectors. For planning purposes, 40 kilometers is the effective line-of-sight range for AMGs in the bypass mode. The planning range for corner reflectors is 10 kilometers.
- Plan for polarization of VHF antennas. AMG antenna polarization is a vital part of link planning.

- Define the patching scheme for each battalion element. Assign antenna azimuths for each link.
- Assign battalion identification numbers to generate RLRIU addresses for local battalion elements. The RLRIU address defines the RLRIU that delivers the data block.
- Identify the interbattalion or extrabattalion exit and entry port (ICC or CRGs 1 through 4) and shelter modem (1 through 5) to be used for each interbattalion or extrabattalion link. Direct linking, discussed later, offers an alternative to the use of modems for interbattalion communications.

PLANNING THE COMMUNICATIONS NETWORK

Communications network planning requires close coordination between the signal officer and the S3 section. The S3 informs the signal officer of proposed unit locations determined by the RSOP. The signal officer determines the need for CRGs based on the distance between units and the terrain. Once the UTM coordinates of the deployed units are known, the locations are plotted on a map to determine profile elevations and verify distance between units. Detailed system planning guidance is provided in TM 11-5820-540-12. The same information displayed on the battalion UHF link diagram (see Figure G-11) will be required in a Patriot three- to six-battery configuration. The diagram should contain the UTM coordinates and elevation data for each ECS, ICC, and CRG.

STANDARDIZATION

Standardization of communications tasks is essential for rapid system emplacement and operations. To the maximum extent possible, basic and redundant communications functions should be standardized.

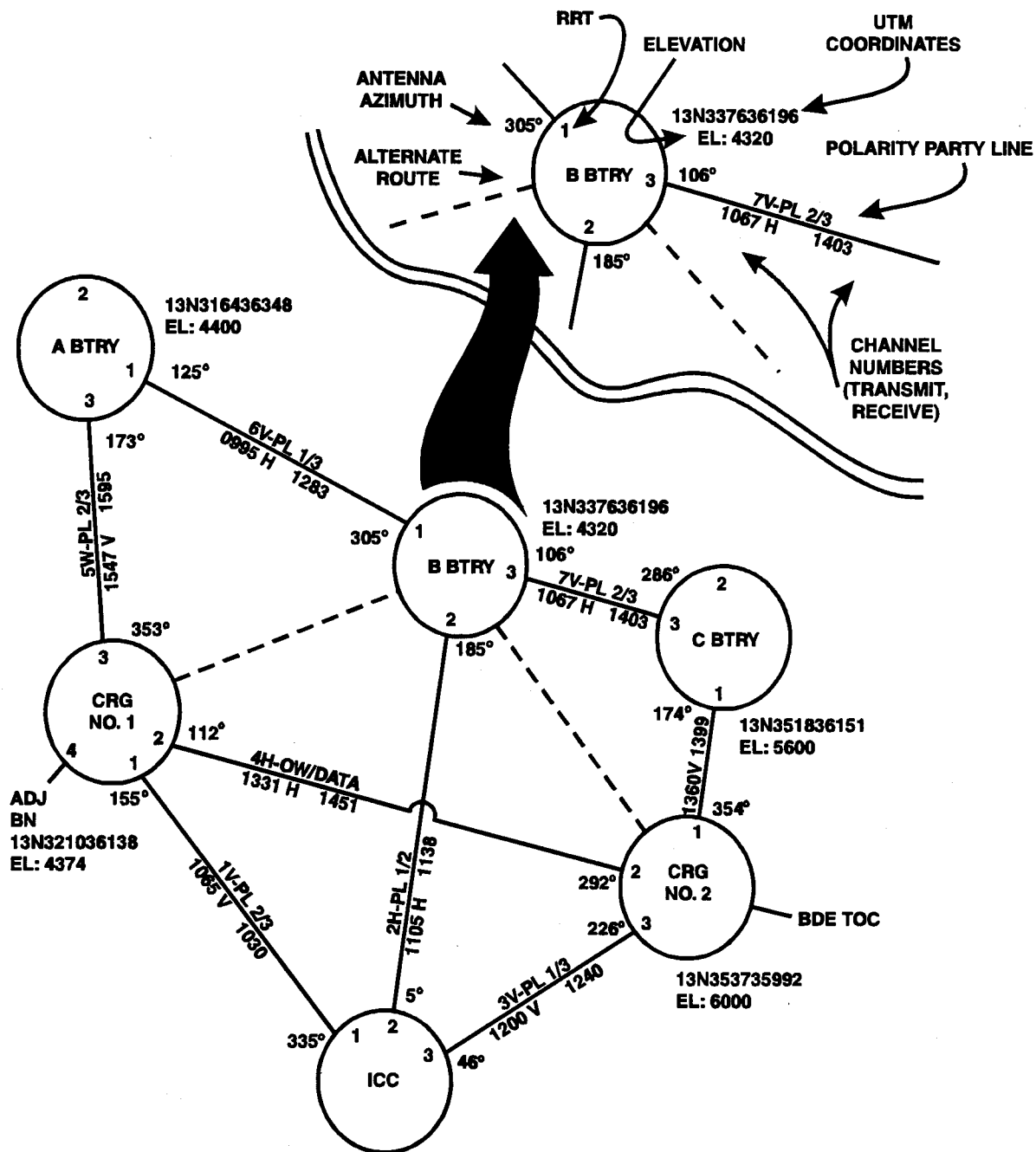

Figure G-11. Battalion UHF system diagram.

Communications Patching Panel

Standardization at the CPP is achieved by the way voice party lines and data channels are patched. Party line 1 is patched to channel one; party line 2 is patched to channel two of whichever RRT is being used. Data channels within the battalion will be patched from RLRIU port 1 to channel three of RRT 1, from RLRIU port 2 to channel four of RRT 2, and so forth. This process will continue until all patching is complete.

Data Channels

One of the first 11 channels should be dedicated for intrabattalion data transmissions. Channel 12 should not be used for data transmission since a synchronized pulse is routinely sampled from this channel. However, channel 12 can be used for voice transmissions.

EXTRABATTALION AND INTERBATTALION COMMUNICATIONS

The five modems at the ICC and CRG are used for communications with brigade and interbattalion communications with adjacent units. Standardization is achieved by assigning, for example, modem 5 to channel 5 of whichever RRT is being used by the ICC or the CRG. Direct linking provides an alternative to the use of modems for interbattalion data communications. This process increases data throughput and provides data flow between lateral ICCs when modem hardware is unavailable. Up to six direct links can be established during initialization. For example, at initialization, the special direct link source codes to be accepted from battalion B over a direct link are set in the battalion A RLRIU. All data packets originating in battalion B will flow over any direct link antenna path established between the

two battalions. Only those data packets carrying the authorized data link source codes will be relayed into the battalion A net and passed into the battalion A computer by the ICC's RLRIU.

At battalion B, the same special direct link source codes are used in the RLRIU. Therefore, packets from battalion A carrying the authorized direct link source codes will also be relayed into the battalion B net and passed into the battalion B computer. A battalion net may also act as a relay between two other battalions using direct linking (see Figure G-12).

Party Line Loops

The party line loops switch located on the front of the CP is also part of communications standardizing. It must remain in the NORM position at all FUs and in the OPEN position at the ICCs and CRGs.

Radio Relay Terminal

Use the same RRT at both ends of the link; for example, RRT 1 at the ICC to RRT 1 at FU 1. By setting up links in this manner, troubleshooting the links using the communications fault data tab at the ICC is made easier.

DEVELOPING DATA LINK NETWORK

In developing the data link network, the signal officer uses the G2, ICC, and CRG deployment FU communications assignment to designate communications links, antenna azimuths, unit ID codes, and CRG locations. Tab 62 is used to assign data and voice partners and is accessible during tactical operations. Tab 62 has been expanded to two pages to allow the addition of six FUs, additional communications links, and antenna azimuths.

The FUs, the ICC, and the CRGs are shown in a 360-degree perimeter (see Figure G-11, page G-13). The distance from a unit to its perimeter represents 20 kilometers (half the nominal communications planning range). In determining whether units can communicate with each other, the individual observes the situation display and notes the

proximity of the units to one another. If the symbols touch or overlap each other, they should be able to communicate without having to relay through a CRG. This assumes that the AMG is used and LOS exists. If the unit symbols do not touch (the overall separation is 40 kilometers or more), a CRG is required.

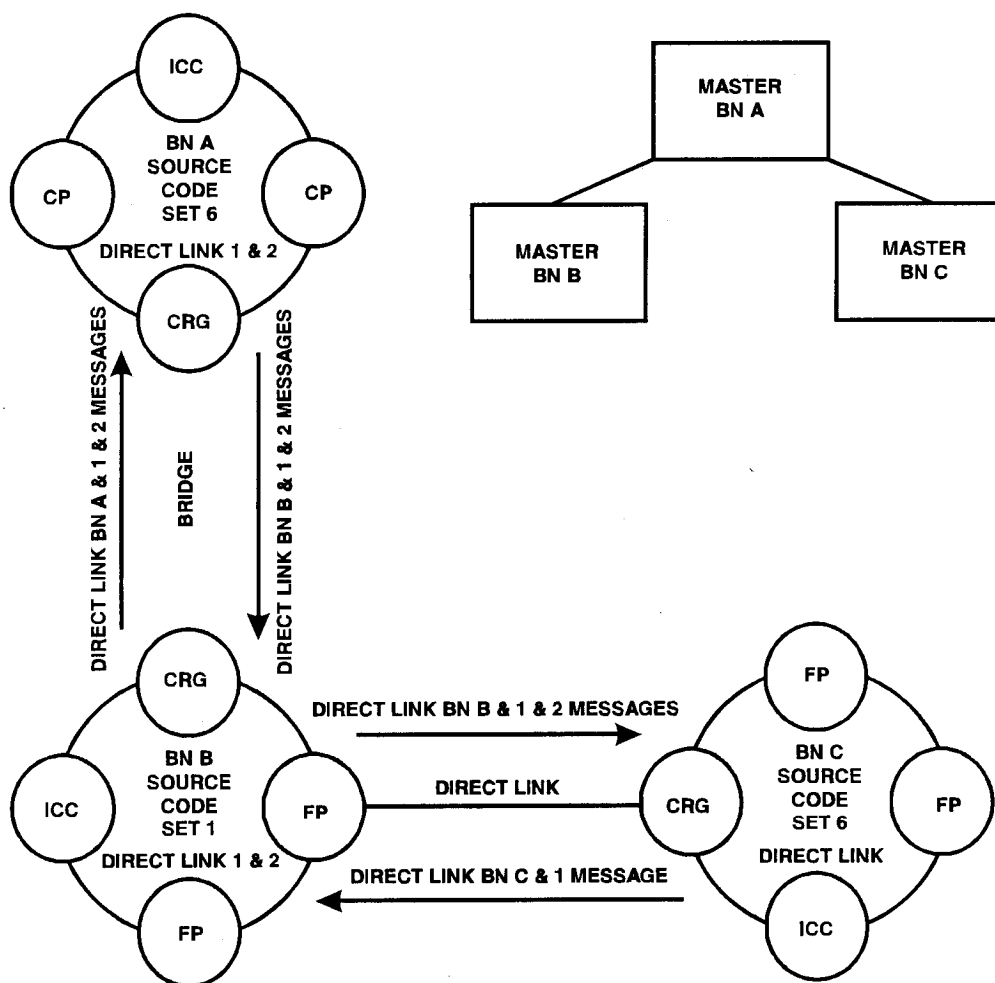

Figure G-12. Direct linking.

INITIALIZATION

When a communications plan is developed, it must be implemented. Operators at the ICC, CRG, and ECS use the previously discussed link diagram and the communications planning work sheet as guides in their emplacement procedures.

Once the system is initialized, the operational software monitors and checks the RRTs, RLRIUs, and modems at all units

(ECS, ICC, and CRG). This information is displayed at the ICC in the communications link fault data tab. The tab, when used with the battalion UHF communications link diagram, is an excellent tool in determining link and equipment status. The information in the tab becomes available when data communications are established between links (RLRIU to RLRIU).

DATA LINK CONSIDERATIONS

Patriot data communications is defined by or limited to the 32 kbps UHF multirouting network. Each linked unit, depending on its data protocol and initialized linkage, uses (loads) a portion of that capacity. If but only a "moderate" number and combination of units (Note: Far less than the maximum number and combination allowed by PDB-3 [Block II] ICC software) are interfaced via the UHF net to the ICC, the net loading capacity of 32 kbps (or 100 percent) can be exceeded.

In the ICC, as a PDB-3 software improvement, the network loading is automatically calculated and displayed for currently linked units as a percentage value in Tab 02.

For planned deployments, this percentage, referred to as the deployed net loading percentage (DNLP) is also calculated and displayed in communications Tabs 67, 68, and 69.

In the ICC, also as a PDB-3 software improvement, data communications can be accelerated between ICCs by initializing a "direct-link." A direct link (up to five are possible) bypasses modem hardware and fully accesses the 32 kbps net capacity.

Data modems located only at the ICC and CRGs, five each per shelter, are required for data communications with ATDL-1 and TADIL-B units; for example, brigade TOC, HEU, GEHOC, CRC, and auxiliary (see Figure G-13).

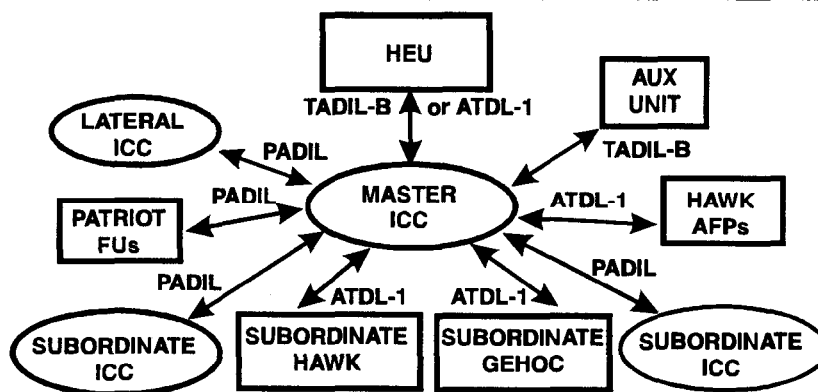

Figure G-13. PDB-3 data link software capability.

TACTICAL CONSIDERATIONS

Patriot communications via UHF are subject to degradation under combat conditions. The following are procedures to help reduce the amount of degradation.

System Loading Reduction Measures

Given DNLP > 100 percent, to maintain optimum system performance, the ICC will automatically degrade gradually its data communications to Patriot FUs first and then to or with CRG modem-ported Hawk fire units (if linked). The number of messages on the link(s) to FUs will be reduced and lower-priority messages for FUs will not be serviced as often. Note: Engagement and engagement-related commands are high-priority messages.

Operator Loading Reduction Measures

Given an overloaded net (DNLP > 100 percent), the ICC operator will be alerted and can take the following actions:

- Disallow communications via Tab 02 to one or more units which reduces that unit's load by approximately one-half. Data still flows from the unit to the ICC.
- Reduce or eliminate "direct-links" to or with subordinate or adjacent ICCs that reduce that link's load by approximately one-third or greater.
- Transfer CRG modem-linked units to ICC modems which reduce that link's load to zero. Data still flows to and from the unit(s). Note, however, that the unit(s) must be relatively close to the ICC as no CRG relay exists, LOS is still required, and data addressed to the ICC is not multirouted.
- Eliminate a data link to a unit(s) via deletion of the unit(s) Tab 68 to 69 at the ICC which reduces that link's load to zero. Data is

disallowed to and from the unit. Note: FU to FU communications have no loading reduction effect since FUs share the ICC's multirouting net.

RECOMMENDATIONS

The following are some basic rules for UHF communications carrying data (additional information can be found in FM 44-85-1 [TBP]):

- Do not "overload." Although loading beyond 100 percent is possible, it certainly is not advisable. An overloaded net will result both by design and fact in degraded data communications.
- Plan load(ing). With predicted "allowable" numbers and combinations of units, a net load planning matrix should be consulted. Should one not be available, as a rough planning tool, use the following figures for prediction: each CRG modem-ported Hawk FU—5 percent; each Patriot FU—10 percent; each initialized external battalion unit linked through CRG modems—15 percent; and on "direct-link"—20 percent.
- Maximize use of ICC modems. Limitations aside (see FM 44-85-1 [TBP]), from a network loading standpoint, maximum use should be made of ICC modems, especially by collocated (1 to 5 kilometers) units, Hawk FUs when CRG availability is limited, and "relatively close" ATDL-1 or TADIL-D units. Again, units linked via these modems do not load the network or in any way affect the network's loading capacity.
- Do not "direct-link." Increased data throughput between ICCs aside (see FM 44-85-1 [TBP]), from a network loading standpoint, minimal use should be made of "direct-linking" due to their exorbitant impact on the network loading capacity. Clearly, however, if loading capacity is sufficient (few links exist), direct links may be considered.

GLOSSARY

A²C²	Army airspace command and control	AMC	United States Army Materiel Command
AA	avenue of approach	AMG	antenna mast group
AADC	area air defense commander	AMS	antenna mast set
AAOA	air avenue of approach	AMTS	active maintenance training simulator
AAR	after action review	AO	area of operations
ABT	air-breathing threat	AOC	air operations center
ac	alternating current	AOR	area of responsibility
ACL	allowable cabin load	AP	antipersonnel
ACO	airspace control order	APO	Army Post Office
acq	acquisition	APOD	aerial port of debarkation
AD	air defense	AR	Army regulation
A/D	analog-to-digital	ARM	antiradiation missile
ADA	air defense artillery	ARNG	Army National Guard
ADCOORD	air defense coordinator	ARTEP	Army Training and Evaluation Program
ADC	air defense control; area damage control	As	antispoofing
ADCP	air defense command post	ASG	area support group
adj	adjacent	ASL	authorized stockage list
ADM	air defense mission	ASM	air-to-surface missile
admin/log	administrative/logistic	ASP	ammunition supply point
ADP	automatic data processing	asst	assistance
adv	advance	ATACMS	Army Tactical Missile System
ADW	air defense warning	ATBM	antitactical ballistic missile
AEE	automatic emplacement enhancement	ATC	air traffic control
AFCC	Air Force Component Commander	ATDL	Army tactical data link
AFP	assault fire platoon	ATGM	antitank guided missile
AI	area of interest	ATM	antitactical missile
AM	amplitude modulation	ATMCT	air terminal movement control team

FM 44-85

ATO	air tasking order	(C)	confidential
ATP	Allied Tactical Publication; ammunition transfer point	C²	command and control
attk	attack	C²I	command, control, and intelligence
attn	attention	C³	command, control, and communications
aux	auxiliary	C³I	command, control, communications, and intelligence
AWACS	Airborne Warning and Control System	CIA	coarse acquisition
az	azimuth	cane	cancelled
BAI	battlefield air interdiction	CAS	close air support; control actuator section
BCU	battery coolant unit	cav	cavalry
BDA	battle damage assessment	CBR	chemical, biological, radiological
BDAR	battle damage assessment and repair	cbt	combat
bde	brigade	ccw	counterclockwise
BDHI	bearing-distance-heading indicator	CE	Communications-Electronics
BIT	built-in test	CEB	clothing exchange and bath
BITE	built-in test equipment	CEP	circular error probable
BME	battalion maintenance equipment	CESO	Communications-Electronics Signal Officer
BMG	battery maintenance group	CFE	contractor furnished equipment
BMNT	before morning nautical time	CG	center of gravity
BMO	battalion maintenance officer	CIS	Commonwealth of Independent States
bn	battalion	CKW	cryptokey weekly
BOS	battlefield operating system	CM	cruise missile
BRU	battery replaceable unit	CMCC	corps movement control center
BSA	brigade support area	CMCT	corps movement control team
BSE	battalion supply and equipment	cmd	command
BTOC	battalion/brigade tactical operations center	CMMC	corps materiel management center
btry	battery	CMP	computer maintenance panel
		co	company

COA	course of action	DEFCON	defense readiness condition
comm	communications	dep	deployed
COMMZ	communications zone	dev	development
COMSEC	communications security	DISCOM	division support command
CONUS	continental United States	div	division
COSCOM	corps support command	DLT	data link terminal
CP	command post; check point	DLU	data link unit
CPP	communications patching panel	DNLP	deployed net loading percentage
CPU	central processing unit	DNVT	digital nonsecure voice terminal
CRC	control and reporting center	DP	decision point
CRG	communications relay group	DS	direct support
CSA	corps storage area	DSA	division support area
CSB	corps support battalion	DSM	decision support matrix
CSC	combat support company	DSS	direct supply support; direct support system
CSG	corps support group	DST	decision support template
CSIU	computer simulator interface unit	DSU	direct support unit
CSR	controlled supply rate	DX	direct exchange
CSS	combat service support	DZ	drop zone
CUG	control unit group	EA	engagement area
CVRT	criticality, vulnerability, recuperability, and threat	EAC	echelons above corps
cw	clockwise	ECCM	electronic counter-countermeasures
DA	Department of the Army	ECM	electronic countermeasures
DAM	display-aided maintenance	ECP	entry control point
dc	direct current	ECS	engagement control station
DCA	defensive counterair	ECU	environmental control unit
DCCS	display and control console simulator	EDWA	engagement decision and weapon assignment
DD	Department of Defense (forms)	EEI	essential elements of information
DDL	digital data link	EENT	early evening nautical time

EMCON	emission control	G4	Assistant Chief of Staff (Logistics)
EMI	electromagnetic interference	GCI	ground-controlled interception
EMMO	electronic missile maintenance officer	GEHOC	German Hawk Operations Center
EMP	electromagnetic pulse	GFE	government furnished equipment
emp	emplace; employed	GIP	ground impact point
EPP	electric power plant	GM	guided missile
EPU	electric power unit	GMT	guided missile transporter
EPW	enemy prisoner of war	GPFU	gas particulate filter unit
EW	electronic warfare; early warning	GPS	global positioning system
EWBN	early warning broadcast network	GS	general support
F	Fahrenheit	GS-R	general support-reinforcing
FARP	forward arming and refueling point	GUK	group unique key
FDC	fire direction center	H	Hawk
FH	frequency hopping	HCU	hard copy unit
FLIR	forward-looking infrared	HE	high explosive
FLOT	forward line of own troops	hel	helicopter
FM	field manual; frequency modulation	HEMTT	heavy expanded mobility tactical truck
FO	fiber optics	HEU	higher echelon unit
FOV	field of view	HHB	headquarters and headquarters battery
FP	firing platoon	HIMAD	high- to medium-altitude air defense
FRG	Federal Republic of Germany	HPI	high-powered illuminator
FROG	free rocket over ground	HQ	headquarters
FSB	forward support battalion	hr	hour
FU	fire unit	HSS	health service support
FW	fixed wing	HVT	high-value target
G2	Assistant Chief of Staff (Intelligence)	ICC	information and coordination central
G3	Assistant Chief of Staff (Operations and Plans)	ID	identification
		IF	intermediate frequency

IFF	identification, friend or foe	LOGPAC	logistics package
IHFR	improved high-frequency radio	LOS	line of sight
inf	infantry	LOTS	logistics over-the-shore
info	information	LP	listening post
intel	intelligence	LRM	launcher response message
IOCU	input/output control unit	LRP	logistical release point
IPB	intelligence preparation of the battlefield	LRPT	large repair parts transporter
IRR	intelligence and radar reporting	LRS	launch recovery site
		LRU	line replaceable unit
		LS	launching station
JFACC	joint force air component commander	LSTS	launching station test set
JTAGS	joint tactical ground station	LZ	landing zone
JTF	joint task force		
		MANPADS	man-portable air defense system
kbps	kilobits per second	MAPS	million ads per second
KDP	known data point	MASINT	measurement and signature intelligence
kg	kilogram	MATO	materiel officer
KIA	killed in action	MBU	master bus unit
km	kilometer	MC	maintenance center; movement completion
KRP	known reference point	MCP	maintenance collection point
kw	kilowatt	MCPE	modular collective protective equipment (entrance)
		MCR	movement completion report
LAM	launcher action message	MCT	movement control team
LASH	lighter aboard ship	MDAGS	modular digital airborne guidance system
LAT	live air trainer	MEDLOG	medical logistics
LD	line of departure	MEO	movement execution order
LEM	launcher electronics module	MET	meteorological
LIG	launcher interconnection group	METL	mission-essential task list
LMA	launcher mechanics assembly		
LMRD	launcher missile-round distributor		

METT-T	mission, enemy, terrain, troops, and time available	NA	not applicable
MILVAN	military van	NAI	named area of interest
MMC	Materiel Management Center	NATO	North Atlantic Treaty Organization
MMP	modular midcourse package	NBC	nuclear, biological, chemical
MMU	monolithic memory unit	NBS	National Bureau of Standards
MOPP	mission-oriented protective posture	NCO	noncommissioned officer
MOS	military occupational specialty	NCOIC	noncommissioned officer in charge
MRBM	medium-range ballistic missile	NCS	net control station
MRCTS	missile-round cable test set	NFS	north finding system
MRE	meal, ready to eat	NPFC	Naval Publications and Forms Center
MRL	multiple rocket launcher	NSL	nonstocked logistics
MRT	missile-round transported movement regulating team; missile-round trainer	NSN	national stock number
MS	manstation	obj	objective
MSB	main support battalion	OIC	officer in charge
MSE	mobile subscriber equipment	OP	observation post
mssl	missile	OPLAN	operation plan
MSR	main supply route	Opnl	operational
MSRT	mobile subscriber radio terminal	OPORD	operation order
MST	maintenance support team	ops	operations
MSU	mass storage unit	OPSEC	operations security
MTM	mask terrain map	ORF	operational readiness FLOAT
MTMC	Military Traffic Management Command	OSLB	operational search lower bound
MTOE	modified table of organization and equipment	OTM	on-line training mode
MTP	mission training plan	OTT	operator tactics trainer
MTTR	mean time to repair	OVM	operator vehicle maintenance
MWO	movement warning order	P	Patriot; precise
N	north	PAC	Patriot advanced capability

PADIL	Patriot digital information link	PSI	pounds per square inch
PCU	peripheral control unit	PTL	primary target line
PDB	post deployment build	PTT	part task trainer
PDU	power distribution unit		
PIR	priority intelligence requirement	QA	quality assurance
P_k	probability of kill	QRP	quick response program
PLGR	precision lightweight GPS receiver		
PL	phase line	RACO	rear area combat operations
PLL	prescribed load list	RAP	rear area protection
PMCS	preventive maintenance checks and services	RARP	rear arming and refueling point
POL	petroleum, oils, and lubricants	reg	regiment
POMT	Patriot organizational maintenance trainer	RF	radio frequency
positive control:	A method of airspace control which relies on real-time data from radars, data links, and intelligence sources. These facilities are vulnerable to electronic interference, attack and sabotage. As a general rule, positive control works best when friendly forces have air superiority. When air superiority gives way to air parity or worse, the stress on the C ² structure makes positive control more difficult to execute.	RFI	radio frequency interference
		RISTA	reconnaissance, intelligence, surveillance, and target acquisition
		RL	remote launch
		RLRIU	routing logic radio interface unit
		RMCT	regional movement control team
		ROE	rules of engagement
		RO/RO	roll on/roll off
		ROW	rest of world
		RP	release point
		RPV	remotely piloted vehicle
		rqr	required
		RRG	radar receiver group
		RRT	radio relay terminal
		RS	radar set
		RSOP	reconnaissance, selection, and occupation of position
		RSU	required supply rate
procedural control:	Management which relies on preplanned techniques such as engagement zones, rules of engagement and weapon control status. This method is less vulnerable to electronic and physical attacks, but is more restrictive in that fratricide is more likely. However, procedural methods significantly enhance continuity of operations under adverse battle conditions.	RSU	recovery storage unit

FM 44-85

RTO	radiotelephone operator	SP	start point
RW	rotary wing	SPG	signal processor group
RWCIU	radar weapons control interface unit	SPOD	seaport of debarkation
RX	repairable exchange	SPS	standard positioning service
		SRBM	short-range ballistic missile
S	south	SRPT	Small repair parts transporter
(S)	Secret	SSM	surface-to-surface missile
S1	Personnel Officer	STANAG	Standardization Agreement (NATO)
S2	Intelligence Officer	ST&HE	special tools and handling equipment
S3	Operations and Training Officer	STL	secondary target line
S4	supply officer	surv	survival
SA	selective availability		
SAM	surface-to-air missile	TAACOM	Theater Army Area Command
SBU	slave bus unit	TAADCOM	Theater Army Area Defense Command
SC	single channel	tac	tactical
Seabee	a type of sea barge	TACAIR	tactical air
SEAD	Suppression of enemy air defense	TACC	tactical air control center
SEN	small extension node	TACI	tactical initialization
SEORAD	short-range air defense	TACS	tactical air control system
SIF	selective identification feature	TADIL	tactical digital information link
SIGINT	signal intelligence	TADS	tactical air defense system
SIG-SEC	signal security	TAI	target area of interest
SINCGARS	single-channel ground and airborne radio system	TAMCA	Theater Army Movement control Agency
SOE	state of emissions	TBM	tactical ballistic missile
SOFA	Status of Forces Agreement	TBP	to be published
SOI	signal operating instructions	TCA	tactical Control assistant
SOJ	standoff jammer	TCO	tactical control officer
SOJC	standoff jammer capability	TD	tactical director
SOP	standing operating procedure	TDA	tactical director assistant

T&E	traverse and elevation	TV	television
tech	technical	TVM	track-via-missile
TF	task force	TVMCP	track-via-missile correlation processor
tgt	target		
TM	technical manual	(U)	unclassified
TMO	transportation movement officer	UAV	unmanned aerial vehicle
TMT	terrain mapping trainer	UHF	ultrahigh frequency
TMU	transmitter maintenance upgrade	ULLS	unit-level logistics system
TNT	troop netted trainer	USAF	United States Air Force
TOC	tactical operations center	USAREUR	United States Army, Europe
TOE	table(s) of organization and equipment	UTM	universal transverse mercator
TPT	troop proficiency trainer		
TRANSCOM	United States Transportation Command	VHF	very high frequency
trig	trigonometry	vic	vicinity
TSA	theater storage area		
TSOP	tactical standing operating procedure	WCC	weapons control computer
TTFL	time-to-first-launch	WCS	weapon control status
TTLL	time-to-last-launch	WSMR	White Sands Missile Range
TTP	tactics, techniques, and procedures	XO	executive officer

REFERENCES

SOURCES USED

These are the sources quoted or paraphrased in this publication.

- AR 380-5. Department of the Army Information Security Program. 25 February 1988.
- (C)AR 380-19-1. Control of Compromising Emanations (U). September 1990.
- AR 710-2. Inventory Management Supply Policy Below the Wholesale Level. 31 January 1992 (Change 1, 28 February 1994).
- ARTEP 44-635-MTP. Mission Training Plan for an ADA Battalion, Patriot. 3 October 1995.
- ARTEP 44-637-30-MTP. Mission Training Plan for an ADA Battery, Patriot. 3 October 1995.
- ARTEP 44-635-1 I-Drill. Patriot Crew Drills for Electric Power Plant (EPP) and Antenna Mast Group (AMG). 11 May 1992 (Change 1, 4 March 1994).
- ARTEP 44-635-12-Drill. Patriot Drills for Information and Coordination Central (ICC), With Electric Power Unit II (EPU II) and Communications Relay Group (CRG). 29 May 1992 (Change 1, 4 March 1994).
- ARTEP 44-635-13-Drill. Patriot Crew Drills for Engagement Control Station (ECS) and Radar Set (RS). 13 July 1992 (Change 1, 15 July 1994).
- ARTEP 44-635-14-Drill. Patriot Crew Drills for Launching Station (LS) and Missile Reload. 30 June 1992 (Change 1, 15 July 1994).
- ARTEP 44-635-15-Drill. Patriot Crew Drills for Launching Station (LS) Forklift Missile Reload. 3 October 1995.
- DA Pamphlet 710-2-1. Using Unit Supply System (Manual Procedures). 1 January 1982 (Change 13, 28 February 1994).
- FM 3-3. Chemical and Biological Contamination Avoidance. 16 November 1992 (Change 1, 29 September 1994).
- FM 3-4. NBC Protection. 29 May 1992 (Change 1, 28 October 1992).
- FM 3-5. NBC Decontamination. 17 November 1993.
- FM 5-36. Route Reconnaissance and Classification. 10 May 1985.
- FM 5-100. Engineer Combat Operations. 22 November 1988.
- FM 10-63-1. Graves Registration Handbook. 17 July 1986.
- FM 10-280. Mobile Field Laundry, Clothing Exchange, and Bath Operations. 22 October 1986.
- FM 10-500-9. Tactics, Techniques, and Procedures for Quartermaster Airdrop and Airdrop Support Units. 3 October 1995.
- FM 24-1. Signal Support in the AirLand Battle. 15 October 1990.
- FM 25-100. Training the Force. 15 November 1988.
- FM 25-101. Battle Focused Training. 30 September 1990.
- FM 34-130. Intelligence Preparation of the Battlefield. 8 July 1994.
- FM 44-80. Visual Aircraft Recognition. 30 September 1996.
- FM 44-64. SHORAD Battalion and Battery Operations (TBP).
- FM 44-71. Air Defense Artillery Brigade Operations (TBP).
- FM 44-73. Tactics, Techniques, and Procedures for Hawk Platoon Operations. 23 December 1992.
- FM 44-85-1. Patriot Tactics, Techniques, and procedures (TBP).
- FM 44-100. US Army Air Defense Artillery Operations. 15 June 1995.

FM 44-85

- (S)FM 44-100A. Air Defense Artillery System Planning Data(U) (TBP).
- FM 54-30. Corps Support Groups. 17 June 1993.
- FM 63-3. Corps Support Command. 30 September 1993.
- FM 63-4. Combat Service Support Operations—Theater Army Area Command. 24 September 1984.
- FM 71-100. Division Operations. 16 June 1990.
- FM 100-5. Operations. 14 June 1993.
- FM 100-10. Combat Service Support. 3 October 1988.
- FM 100-15. Corps Operations. 13 September 1989.
- FM 100-16. Army Operational Support. 31 May 1995.
- FM 100-42. US Air Force/US Army Airspace Management in an Area of Operations. 1 November 1976.
- FM 100-103. Army Airspace Command and Control in a Combat Zone. 7 October 1987.
- FM 101-5. Staff Organization and Operations. 25 May 1984.
- FM 101-5-1. Operational Terms and Symbols. 21 October 1985.
- Joint Publication 0-2. Unified Action Armed Forces (UNAAF). 11 August 1994.
- Joint Publication 1-02. Department of Defense Dictionary of Military and Associated Terms. 23 March 1994.
- Joint Publication 3-0. Doctrine for Joint Operations. 1 February 1995.
- Joint Publication 3-01.1. Joint Doctrine for Defense of the United States Against Air Attack. 11 February 1982.
- Joint Publication 3-01.2. Joint Doctrine for Theater Counterair Operations. 1 April 1986.
- Joint Publication 3-01.5. Doctrine for Joint Tactical Missile Defense. 30 March 1994.
- MIL-STD-209. Slings and Tie-Down Provisions for Listing and Tying Down Military Equipment. 28 June 1991 (Revision H).
- TB 43-0142. Safety Inspection and Testing of Lifting Devices. 30 August 1993 (Change 2, 28 February 1995).
- TB 43-0209. Color, Marking and Camouflage Painting of Military Vehicles, Construction Equipment, and Materials Handling Equipment. 31 October 1990 (Change 1, 7 May 1991).
- (S)TB 380-6-8. Signal Security (SIGSEC) for Air Defense Artillery Battlefield Survivability(U). 15 November 1992.
- TM 9-1425-600-12. Operator's and Organization Maintenance Manual for System Description (Patriot Air Defense Guided Missile System). 31 December 1991 (Change 1, 22 May 1995).
- TM 9-1430-600-10-1. Operator's Manual for Engagement Control Station, Truck-Mounted: AN/MSQ-104 (Patriot Air Defense Guided Missile System). 20 March 1995.
- TM 9-1430-601-10-1. Operator's Manual for Radar Set, Semitrailer-Mounted: AN/MPQ-53 (Patriot Air Defense Guided Missile System). 31 August 1993 (Change 2, 26 May 1995).
- TM 9-1430-602-10-1. Operator's Manual for Information and Coordination Central, Truck-Mounted: AN/MSQ-116 (Patriot Air Defense Guided Missile System). 10 May 1995.
- TM 9-1440-600-10. Operator's Manual for Launching Station, M901 Semitrailer-Mounted (Patriot Air Defense Guided Missile System). 23 September 1993.
- TM 10-3930-243-12. Operator's and Organizational Maintenance Manual for Truck, Lift, Fork; Diesel Engine, Pneumatic Tired Wheels, Rough Terrain; 10,000 Lb Capacity, 24-Inch Load Center (Pettibone-Mulliken Model RTL 10) Army Model MHE-199 With Roll-Over Protective Structure Army Model MHE-199. 3 June 1971 (Change 6, 30 July 1991).

References-2

TM 10-3930-643-10. Operator's Manual Truck, Forklift, DED Pneumatic Tire, 10,000 Lb Capacity Rough Terrain, Articulated Frame Steer. 19 January 1990.

TM 11-5820-540-12. Operator's and Unit Maintenance Manual for Radio Set, AN/GRC-103(V)1, AN/GRC-103(V)2, AN/GRC-103(V)3, AN/GRC-103(V)4 and Extension Kit, Mast, MK-1009/GRC-103 (V). 1 July 1988.

TM 11-5825-275-23. Organizational and Direct Support Maintenance Manual for Manpack Navigation Set AN/PSN-8, Vehicular Navigation Set AN/VSN-8. 1 October 1989.

DOCUMENTS NEEDED

These documents must be available to the intended users of this publication.

DA Form 12-1 I-E. Subscription Numbers, Part V (FMs, MQSs, STPs, and TCs). 1 March 1988.

DA Form 581. Request for Issue and Turn-In of Ammunition. August 1989.

DA Form 2028. Recommended Changes to Publications and Blank Forms. 1 February 1974.

DA Form 2765. Request for Issue or Turn-In. April 1976.

DA Form 5988-E. Equipment Inspection Maintenance Worksheet. March 1991.

DD Form 1425. Specifications and Standards Requisitions. March 1986.

READINGS RECOMMENDED

These readings contain relevant supplemental information. These international agreements are available on request from the Naval Publications and Forms Center (NPFC), 5901 Tabor Avenue, Philadelphia, PA 19120. Use DD Form 1425 to requisition documents.

STNAG	TITLE	EDITION
2175	Classification and Designation of Flat Wagons Suitable for Transporting Military Equipment	3
2832	Restrictions for the Transport of Military Equipment by Rail on European Railways	2
3700	NATO Tactical Air Doctrine-ATP-33(B)	4
3736	Offensive Air Support Operations—ATP-27(B)	8
3805	Doctrine and Procedures for Airspace Control in Time of Crisis and War—ATP-40(A)	4
3880	Counter Air Operations—ATP-42(B)	2

INDEX

- ADA role**, 1-1
- air avenues of approach (AAOAs)**, 3-7, 5-3, C-3, C-6
- air battle management**, 5-9, 5-20
- air battlefield environment**, C-2
- air breathing threat (ABT)**, 3-1, 4-1, 5-1, 5-4, 5-8 thru 5-10
 - defense design, 5-5, 5-6, 5-14 thru 5-17
 - heavy defense, 5-17
- air threat**, 2-1, 2-3, 3-4, C-1, C-2
 - capabilities, C-5
 - courses of action, C-6
 - data, C-4
 - evaluation, C-4, C-5
 - operations update and analysis, C-6
 - point of origin, C-4
 - types, C-3
- antenna mast group (AMG)**, B-4, B-6, B-16, B-23, B-30, B-40, B-47
 - transportability, E-12, E-13
- area damage control (ADC)**, 6-19 thru 6-21
- Army mission**, 1-1
- attack warnings**, B-13
- automatic emplacement enhancement (AEE)**, 5-21, B-29
- backbrief**, 3-5, 3-8 thru 3-11
- ballistic missile**, 2-3, 2-6
 - antitactical ballistic missile (ATBM), 5-17
 - medium-range ballistic missile (MRBM), 2-3
 - short-range ballistic missile (SRBM), 2-3
 - tactical ballistic missile (TBM), 2-1, 2-3, 2-6 thru 2-8, 3-1, 3-7, 4-2 thru 4-5, 5-1 thru 5-5, 5-7 thru 5-10, 5-13, 5-14, 5-17, 5-20, B-1, B-22, C-3, C-5
- battalion**
 - command FM net, G-4, G-5
 - communications equipment, G-1
 - communications requirements, G-2 thru G-7
 - headquarters, B-36, B-41, G-3
 - planning, 3-7, 3-8
- battery commander**, 6-1, 6-7, 6-18, 6-22, 6-23, C-1
 - communications requirements, G-8
 - elements, 6-5
 - executive officer, 6-5
- battle books**, D-1 thru D-8
- battlefield operating systems (BOSSs)**, 3-2, 3-3, C-2
- built-in test equipment (BITE)**, B-1, B-24, B-25, B-30 thru B-32
 - panel, B-6, B-14, B-15
- CEASE FIRE**, B-12
- checklists**
 - Battery Commander's, A-7
 - Briefing, A-8, A-9
 - Communications Equipment, A-4, A-5
 - Convoy, A-16, A-17
 - CP, A-14 thru A-16
 - Ground Defense, A-13, A-14
 - Individual- and Crew-Served Weapons, A-5
 - MANPADS (Stinger), A-5, A-6
 - MILVAN Load, A-29 thru A-39
 - MILVAN Unload, A-18 thru A-28
 - Patriot Equipment, A-3
 - Power Generator, A-4
 - RSOP, A-9 thru A-12
 - Soldier's, A-1
 - Staff Coordination, A-12, A-13
 - Towed Load, A-2
 - Unit Vehicle, A-2
- combat service support (CSS)**
 - ADA brigade, 6-2
 - combat support company (DS), 6-6
 - operations, 6-7
 - Patriot battalion, 6-2 thru 6-4
 - Patriot battery, 6-4 thru 6-6

- command and control (C²),** 1-2, 2-7, 3-1, 3-3, 5-3, 6-9, 6-18, 6-22, 6-23, B-1
 - air defense, 5-20
 - battalion planning, 3-7
 - battle command, 3-3
 - command post, 5-19
 - communications, G-1, G-2, G-4, G-6, G-8
 - deployment and entry operations, 4-3
 - display and control group, B-10
 - facilities, 5-19
 - fire direction center, 5-19
 - predeployment, 4-2
 - support platoon, B-47
 - tactical operations center, 5-19
 - task force, 5-9, 5-10, 5-13
- command, control, communications, and intelligence (C³I),** 2-8, 5-3, 5-19, 5-20
 - defensive operations, 5-4
 - deployment and entry operations, 4-3
- command post (CP)**
 - C³I, 5-19
 - operations security, 6-21
 - S1 section, 6-3
- communications,** 5-19, 6-6, 6-8, 6-9, B-3, B-4, B-45, B-47
 - ABT defense design, 5-5
 - battalion equipment, G-1
 - battalion requirements, G-2 thru G-7
 - battery requirements, G-8 thru G-11
 - combat support company, 6-6
 - command post, 5-19
 - planning, G-12 thru G-16
 - security, B-16
 - UHF, B-15, B-16, B-23, B-47, E-12
 - voice, B-4, B-12, B-17
 - wire, B-18, B-19
- communications relay group (CRG),** B-22, transportability, E-10 thru E-12, E-14
- concept of operations,** 3-5, 3-7, 5-5, 6-7
- contingency theater threat,** 2-1 thru 2-6
- control indicator panel,** B-10, B-11
- control keyboard assembly,** B-12, B-13
- cover and concealment,** 6-8
 - masking, C-2 thru C-4
- data link**
 - considerations, G-16, G-17
 - network, G-14, G-15
 - terminal module B-31
- decision support matrix (DSM),** 3-1, 3-4 thru 3-10
- decision support template (DST),** 3-1, 3-4, 3-5, 3-7, C-6, C-7
- decontamination,** 6-19, 6-21 thru 6-24
- defensive operations,** 5-4, 5-5
 - ABT defense design, 5-5, 5-6
 - design recommendations, 5-14 thru 5-18
 - TBM defense design, 5-7
- deployment and entry operations,** 4-3
- display and control group,** B-10
- doctrine,** 1-1, 1-2, 2-2, 3-7, 5-2, 6-1, C-1, C-3 thru C-6
- drones,** 2-1, 2-2
- electric power plant (EPP),** B-20, B-30, transportability, E-13, E-14
- emplacement,** 5-21
 - automatic emplacement enhancement (AEE), 5-21, B-29, B-30
- engagement control station (ECS),** B-4, B-5
 - shelter, B-6 thru B-9
 - transportability, E-3, E-7, E-8
- ENGAGE HOLD,** B-12
- environmental control unit (ECU),** B-28
- event template,** C-6
- field services,** 6-19
- fixed-wing aircraft,** 2-6
- force-projection operations,** 3-1, 4-1
 - applicability 4-1
 - considerations 4-5

- deployment and entry operations 4-3
 - predeployment activity 4-2
 - war termination and postconflict operations 4-4
- global positioning system (GPS), 5-13, B-29, B-30**
- guided missile, B-32 thru B-34**
transportability, E-2
- HOLD FIRE, B-12**
- identification, friend or foe (IFF) group, B-28**
- intelligence preparation of the battlefield (IPB),**
C-1 thru C-7
threat, 2-1, 2-6, 2-7
- launcher**
electronics assembly, B-31
generator set, B-31
interconnection group, B-32
mechanics assembly, B-31
- launching station (LS), B-30**
transportability, E-5
- lifting and tie-down provisions, E-4 thru E-14**
- logistics, 6-3, 6-4**
combat service support, 3-3, 6-3
communications, G-4
task force, 5-11
- maintenance**
battle damage assessment, 6-18
cannibalization, 6-18
controlled exchange, 6-18
depot-level, 6-17
DS/GS, 6-16
operator, 6-16
recovery and evacuation, 6-17
trainers, B-40, B-41
- medical support procedures, 6-23**
- missile availability, 2-3**
- mobile subscriber equipment (MSE), G-1**
- north finding system (NFS), B-29, B-30**
- observation and fields of fire, C-2**
- obstacles C-3**
- offensive operations, 5-1 thru 5-3**
- operations security (OPSEC), 6-21**
- operator maintenance, 6-16**
- operational readiness float (ORF), 6-17**
- organizations and functions, 6-1 thru 6-6**
- planning**
ADA brigade, 3-3, 3-4 thru 3-6
communications network, G-12
considerations, 3-3
logistics, 6-7, 6-12
- primary target line (PTL)**
convergent, 5-5 thru 5-7
divergent, 5-6
parallel, 5-6
- quick response program (QRP), 5-13**
- radar set (RS), B-24 thru B-30**
transportability, E-4, E-5
- rear area combat operations (RACO), 6-19**
- rear area protection (RAP), 6-19 thru 6-21**
- reconstitution**
battle damage control, 6-23
commander's assessment, 6-23
planning and training, 6-24
principles, 6-22
responsibilities at battalion level, 6-23, 6-24
responsibilities at battery level, 6-22

- site determination, 6-23
- support unit, 6-23
- recovery and evacuation, 6-17**
- rehearsals**
 - ADA brigade, 3-10
 - Patriot battalion, 3-10
 - Patriot battery 3-11
- remote launch (RL), 5-20**
- routing logic radio interface unit (RLRIU), B-18**
- rotary-wing aircraft, 2-2, 2-3**
- safety**
 - administrative, F-1
 - RF radiation hazards and launcher backblast, F-2
 - risk management process, F-1
 - vehicle movement and convoys, F-1
- secondary target lines, 5-6**
- standing operating procedures (SOP), 3-9**
- supply**
 - categories, 6-10
 - classes, 6-11 thru 6-16
 - distribution methods, 6-10
- tactical equipment, weights and dimensions, B-41 thru B-44**
- tactical standing operating procedures (TSOP), 3-9**
- task force**
 - HIMAD, 5-7 thru 5-13
- TBM defense design, 5-7**
- TBM-heavy defense, 5-14**
- threat, 2-1 thru 2-8**
 - as the lodgment expands, 2-8
 - during lodgment, 2-7
- transportation, 6-18, 6-19**
- transportability, E-1 thru E-14**
 - air, E-3
 - documentation, E-2
 - highway, E-2
 - rail, E-1
 - requirements data, E-1
 - sea, E-2
- UHF transmitter-receiving terminals, B-15, B-16**
- unmanned aerial vehicle (UAV), 2-2**
- vehicle movement and convoys, F-1**
- voice communications, B-17, B-18**
- war-gaming, 3-8**
- weather analysis, C-4**
- wire communications, B-18, B-19**
- weapons control computer (WCC), B-7 thru B-9**
 - central processing unit, B-8
 - computer maintenance panel, B-9
 - hard copy unit, B-8
 - input/output control unit, B-8
 - mass storage unit, B-9
 - monolithic memory unit, B-8
 - peripheral control unit, B-8
 - programs, B-9
 - recovery storage unit, B-8

FM 44-85
21 FEBRUARY 1997

By Order of the Secretary of the Army:

Official:

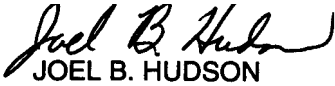
JOEL B. HUDSON
*Administrative Assistant to the
Secretary of the Army*
03029

DENNIS J. REIMER
*General, United States Army
Chief of Staff*

DISTRIBUTION:

**Active Army, Army National Guard, and U.S. Army Reserve: To be distributed
in accordance with the initial distribution number 115471, requirements for
FM 44-85.**